

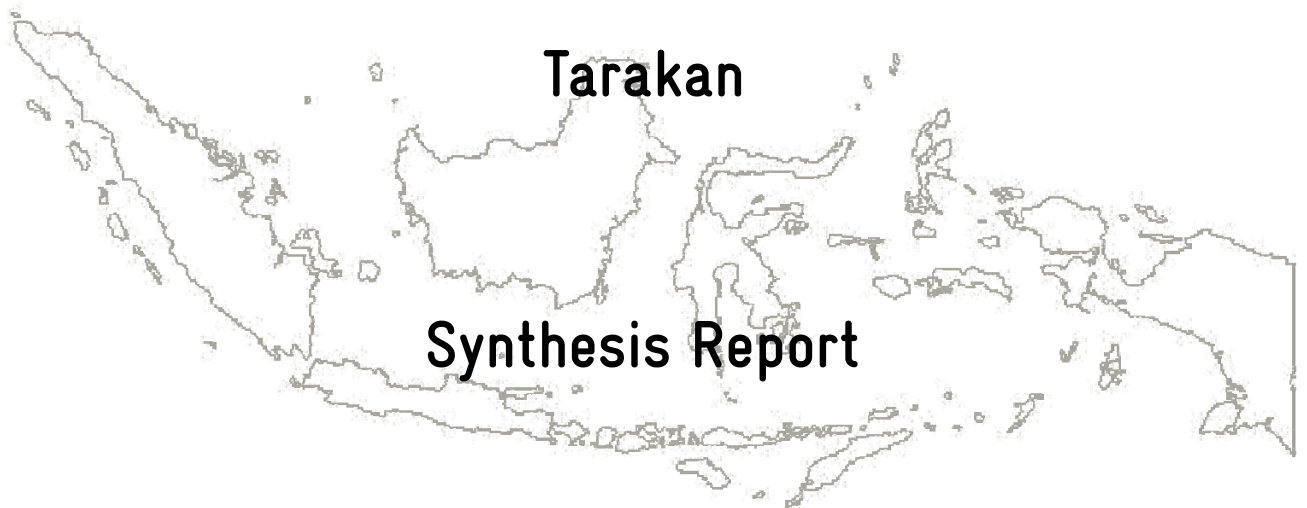

# Climate Change Risk and Adaptation Assessment

Tarakan



Synthesis Report

June 2012



Ministry of Environment

## **Climate Risk and Adaptation Assessment of Tarakan – Synthesis Report**

© 2012 Ministry of Environment

### **Published by:**

Ministry of Environment

Gedung B Lt.4, Jl D.I. Panjaitan kav. 24,  
Jakarta 13410

Tel : [+6221 858 0081](tel:+62218580081)

Fax : [+6221 858 0081](tel:+62218580081)

Email : [slhi@menlh.go.id](mailto:slhi@menlh.go.id) / [adaptation.moe.id@gmail.com](mailto:adaptation.moe.id@gmail.com)

ISBN: 978-602-8358-53-8



The content and material in this book can freely be reproduced and publicized with the condition of not altering the content and meaning of this document. Quoting is permissible by mentioning the source.

The development of this document was supported by:





# Authors

## Adviser

Prof. Dr. Balthasar Kambuaya, MBA, Ministry of Environment

## Coordinator

Ir. Arief Yuwono, MA, Deputy Bidang Pengendalian Kerusakan Lingkungan dan Perubahan Iklim

## Editor in Chief

Ir. Emma Rachmawaty, M.Sc, Asisten Deputy Adaptasi Perubahan Iklim

## Team from Ministry of Environment

drs. Haneda Sri Mulyanto, MAS

Ir. Tri Widayati, MT

dra. Kusmulyani, MS

Koko Wijanarko, S.Hut

Yulia Suryanti, S.Si., M.Sc

Astutie Widyarissantie, ST

## Team from AusAID

Didi Marjimi

Amrita Wedha

## Team from GIZ

Tilman Hertz

Ni Luh Made Ashanapuri

Coordinator of Expert Team	: Djoko Santoso Abi Suroso, PhD
Assistant to the Coordinator	: Muhammad Suhardjono Fitriyanto, M.Sc
Policy Expert	: Wilmar Salim, PhD
Climate & Temperature Projection Expert	: Dr. Tri Wahyu Hadi
Sea level rise Projection Expert	: Dr. Ibnu Sofian
Marine and Coastal Expert	: Dr. Hamzah Latief
Water Resource Expert	: Dr. Oman A., Dr. Budhi S.
Health Expert	: Prof. Ridad Agoes, Dr. Asep Sofyan
Agriculture Expert	: Prof. Handoko, Dr. Ruminta

## Administration Team:

Mendur Lestira

Harliana

Cover picture by Darmastyo Wicaktomo Sudarto

# Acknowledgment

The publication of this report has been made possible by the high degree of commitment and cooperation between all parties involved. The Ministry of Environment would like to thank all working units of local government in Tarakan City, South Sumatera Province, Malang Raya Area (Kota Malang, Kabupaten Malang, Kota Batu), GIZ and AusAID, We are grateful to the many representatives from local governments and universities who have contributed and supported directly and indirectly the preparation of this report. We thanked for shared information, experiences, and opinions gathered in the framework of many project events; public consultations, prioritization of adaptation options, synchronizaiton and mainstreaming events. It has helped considerably the completion of the assessment.

# Foreword by the Deputy Minister for Environmental Damage Control and Climate Change

The impacts of climate change are already being felt all over Indonesia: extreme climate events have hit several parts of Indonesia in the past and have shown that the country is highly vulnerable to the impacts of climate change. Therefore we need real action to improve community resilience to foster resistance to shock and climate disruption, as an essential component for sustainable development. Indonesia has a coastline of approximately 80,000 km and more than 17,000 islands. Many economic activities are carried out in coastal areas and many people's livelihoods depend on sectors that are highly sensitive to climate change, such as the agricultural sector. Due to these geographical conditions, Indonesia is highly vulnerable to climate change. Increasing the resilience to climate change is therefore an important task.

Even though future climate - as a result of climate change - can be said to be subject of uncertainty, we must begin now to develop a strategy to address issues of climate variability and to understand the impact based on the knowledge that the most cutting-edge techniques available up to date can provide us with.

Vulnerability to climate change is often specific to the local context. Hence, understanding climate change impacts at the local level is important and fundamental for addressing climate change. This can be best achieved by the implementation of a Risk and Adaptation Assessment to climate change. Such an assessment can be done at a general level (macro scale), intermediate level (meso scale) or detailed level (micro scale), depending on what kind of information is required.

The Government of Indonesia, through the Ministry of Environment and with support from AusAID and GIZ, has conducted a Risk and Adaptation Assessments to climate change (Krapu) at several pilot sites, for the island of Lombok, for South Sumatra Province, for the Greater Malang area (meso scale) as well as the for the City of Tarakan (micro scale). The implementation of these studies began with a public consultation to identify vulnerable sectors affected by climate change, it continued with a synchronization of programs at local and national levels, and ended with the integration of recommendations from the assessment of options and climate change adaptation strategies into local development and spatial planning.

There are many things that can be learned from each assessment as well as from the context and particularities of the different regions. Some important lessons learned are:

- The importance of ensuring the availability and accessibility of data series that can be used for the Risk and Adaptation Assessment, especially for the preparation of information about current and projected climate change (esp. rainfall patterns, temperature) and sea level rise;

- The importance of ensuring the availability and accessibility of data related to social, economic and development planning, present and future, so that the Climate Risk can be better estimated;
- The importance of increasing the amount of available resources and capacities, including funding for adaptation action itself but also for the continued formation of experts through increased funding for research and development.
- The importance of exploring the potential of local knowledge when it comes to climate change adaptation.
- The importance of synchronizing and harmonizing national and regional development programs with the climate change adaptation options proposed by the experts.

The studies conducted in South Sumatra Province, the City of Tarakan and Greater Malang (District of Malang, Cities of Batu and Malang) identified four sectors that are particularly vulnerable to the impacts of climate change, namely the coastal sector (including fisheries and marine affairs), the water (including water resources, floods and landslides), agriculture, and health sectors. Recommendations from this study may be one input for the development planning processes in South Sumatra Province, City of Tarakan and Malang (District of Malang, Cities of Batu and Malang) through the integration of its results into the RPJMD, RPJP, and other planning tools.

The implementation of this study is expected to be a best practice example for addressing climate change at local level, and it is expected to be replicated in other areas in Indonesia in order to increase Indonesia's resilience to the impacts of climate change.

While carrying out this study, the local governments of South Sumatra Province, the City of Tarakan and the Greater Malang (District of Malang, Cities of Batu and Malang) have greatly supported the process. Hereby, I would like to thank them for their continued and valuable contribution.

Jakarta, June 2012

Deputy MENLH  
Deputy Minister of Environmental Damage Control  
and Climate Change



Arief Yuwono



## Table of Contents

Authors .....	i
Table of Contents .....	i
List of Figures .....	v
List of Tables .....	ix
1. Description and Strategic Issues of Tarakan.....	11
1.1 Physical conditions .....	11
1.1.1 Geographical and Geological Setting of Tarakan City .....	11
1.1.2 Physical Development Growth in Tarakan City .....	15
1.2 Socioeconomic conditions .....	16
1.2.1 Population .....	16
1.2.2 Livelihood .....	17
1.2.3 Economic Structure .....	17
1.3 Strategic Issues .....	18
2. Supporting Scientific Data .....	20
2.1 Analysis and Projection of Climate .....	20
2.1.1 Mean Annual Pattern of Rainfall and Temperature in Tarakan.....	20
2.1.2 Historical Climatic Hazards: Trend, Variability, and Extremes.....	21
2.1.3 Projection of Future Rainfall and Temperature Changes.....	25
2.1.4 Analysis of Extreme Events .....	28
2.2 Analysis and Projection of Sea Level Rise and Extreme Events.....	30
2.2.1 Background: Mean Annual Patterns of Sea Level, Surface Currents, Tidal Level, and Currents, and Wind Waves.....	30
2.2.2 Historical Analysis of Sea Surface Temperature and Sea Level Rise: Trend, Extremes .....	32
2.2.3 Projection of Sea Surface Temperature and Sea Level Rises.....	33
2.2.4 Wave Height Characteristics.....	36
3. Methodology of Risk and Adaptation Assessment .....	37
3.1 Approach, Conceptual Framework, Steps, and Time Frame.....	37
3.2 Methodology for Hazard Analysis .....	40
3.2.1 Coastal Sector Hazards Model and Scenario .....	41
3.2.2 Water Sector Hazards Model and Scenario.....	44
3.2.3 Health Sector Hazards Model and Scenario .....	45
3.3 Methodology for Dynamic Vulnerability Analysis .....	48
3.4 Methodology for Risk Analysis.....	50
3.5 Methodology for Adaptation Formulation and Prioritisation.....	50
4. Risk Assessment and Adaptation Options in Coastal Sector .....	51
4.1 Results of Hazard Analysis .....	51
4.1.1 Characteristics of Hazard Elements.....	51
4.1.2 Cumulative Hazard Map.....	52
4.2 Results of Vulnerability Analysis .....	53
4.3 Results of Risk Analysis .....	57
4.3.1 Risk Level Mapping.....	57
4.3.2 Impact of Risk on Spatial Planning .....	58
4.4 Adaptation Option .....	61
5. Risk Assessment Result and Adaptation Options in Water Sector .....	64
5.1 Results of Hazard Analysis.....	64
5.1.1 Hazard Analysis for Flood .....	64

5.1.2 Hazard Analysis for Landslide.....	66
5.1.3 Hazard Analysis for Water Shortage.....	67
5.2 Results of Vulnerability Analysis.....	69
5.2.1 Vulnerability Analysis of Flood Hazard.....	69
5.2.2 Vulnerability Analysis of Landslide Hazard .....	70
5.2.3 Vulnerability Analysis of Water Shortage Hazard .....	72
5.3 Results of Risk Analysis .....	73
5.3.1 Flood Risk .....	73
5.3.2 Landslide Risk.....	75
5.3.3 Water Shortage Risk.....	77
5.4 Adaptation Options .....	78
5.4.1 Adaptation for Flood.....	79
5.4.2 Adaptation for Landslide .....	83
5.4.3 Adaptation for Water Shortage.....	85
6. Risk Assessment Result and Adaptation Options in Health Sector .....	88
6.1 Results of Existing Hazard Analysis .....	88
6.1.1 Hazard Analysis of DHF .....	88
6.1.2 Hazard Analysis of Diarrhea .....	94
6.1.3 Hazard Analysis of Malaria .....	95
6.2 Results of Projection Hazard Analysis for Year 2030 .....	97
6.2.1 Results of DHF Hazard Projection in Tarakan 2011-2030.....	97
6.2.2 Results of Diarrhea Hazard Projection in Tarakan 2011-2030.....	99
6.2.3 Results of Malaria Hazard Projection in Tarakan 2011-2030.....	100
6.3 Results of Existing Vulnerability Analysis .....	102
6.3.1 Vulnerability Assessment of DHF.....	102
6.3.2 Vulnerability Assessment of Malaria and Diarrhea .....	103
6.4 Results of Projection Vulnerability Analysis for 2030.....	106
6.4.1 Results of DHF Vulnerability Analysis for 2030.....	106
6.4.2 Results of Malaria Vulnerability Analysis for 2030 .....	107
6.4.3 Results of Diarrhea Vulnerability Analysis for 2030 .....	108
6.5 Results of Existing Risk Analysis.....	109
6.5.1 Results of DHF Risk Analysis .....	109
6.5.2 Results of Diarrhea Risk Analysis.....	112
6.5.3 Results of Malaria Risk Analysis.....	114
6.6 Results of Projected Risk Analysis for 2030.....	116
6.6.1 Projection Risk of DHF in 2030 .....	116
6.6.2 Projection Risk of Diarrhea in 2030.....	118
6.6.3 Projection Risk of Malaria by 2030.....	119
6.7 Adaptation Options .....	121
6.7.1 Adaptation Option of DHF Risk.....	123
6.7.2 Adaptation Options of Malaria.....	125
6.7.3 Adaptation Options of Diarrhea.....	126
7. Multi-risk Assessment and Adaptation Prioritisation .....	129
7.1 Multi-risk Assessment.....	129
7.2 Prioritised Areas for Adaptation .....	131
8. Mainstreaming CCRAA into Development Planning .....	133
8.1 Review of Local Long-Term and Medium-Term Development Plans .....	136
8.1.1 Tarakan City RPJP 2005 – 2025.....	136
8.1.2 Tarakan City RPJM 2010 – 2014.....	138
8.1.3 Adaptation Compatibility to Tarakan City RTRW 2010 – 2030 .....	141
8.2 Compatibility Process .....	143
8.2.1 Example in Coastal Sector.....	144

8.2.2 Example in Water Sector .....	146
8.2.3 Example in Health Sector.....	148
8.3 Synchronisation Process .....	150
8.3.1 Example in Coastal Sector.....	150
8.3.2 Example in Water Sector .....	150
8.3.3 Example in Health Sector.....	151
8.3 Champion Programme.....	151
References .....	154
Appendix .....	156
A.1 Compatibility Matrices .....	157
A.1.1 Coastal Sector .....	157
A.1.2 Water Sector.....	160
A.1.3 Health Sector.....	164
A.2 Synchronization/Policy Matrices.....	172
A.2.1 Coastal Sector .....	172
A.2.2 Water Sector.....	174
A.2.3 Health Sector.....	177
A.3 Champion Program .....	183



## List of Figures

Figure 1.1 Location of Tarakan and its surrounding areas (source: Googlemap) ...	12
Figure 1.2 Map of Population Density in Tarakan City .....	17
Figure 2.1 Mean annual variation of monthly (a)rainfall and (c)temperature, while (b) and (c) show the corresponding anomalies relative to long-term average as indicated by the red dashed lines. ....	21
Figure 2.2 Trends in temperature changes in Tarakan over the past century. Red solid line is smoothed monthly temperature data, while blue, green, and orange lines indicate linear trends for the last 100, 50, and 25 years respectively. ....	22
Figure 2.3 Correlation between 6-monthly Standardized Precipitation Index (SPI) calculated from rainfall of Tarakan and Dipole Mode Index (DMI)(left) as well as ENSO index (Nino3.4 sea surface anomaly)(right).....	23
Figure 2.4 Smoothed time series of monthly rainfall observed in Tarakan from 1911 to 2009. Large gap between 1940 and 1950 indicates missing data.....	25
Figure 2.5 Box-plot diagrams showing statistics of monthly rainfall and temperature for June-July-August and December-January-February periods in every decade since year 1951. Upper and lower ends of the boxes designate lower and upper quartiles, while red lines indicate median values. In addition, dotted lines represent minima and maxima, whereas red dots indicate outliers. ....	25
Figure 2.6 Result of empirical regression between PDO and NAO indices and smoothed annual rainfall observed over Tarakan (black line). Time window between blue dashed lines indicate “testing” period and red line shows projected rainfall 2010. ....	26
Figure 2.7 The GCM out based projected monthly rainfall of Tarakan for the 21 <sup>st</sup> century (left) and the smoothed version with an extension back to 1951 (20 <sup>th</sup> century) (right).....	27
Figure 2.8 The GCM out based projected temperature of Tarakan for the 21 <sup>st</sup> century with an extension back to 1951 (20 <sup>th</sup> century). Data has been smoothed to show only the long-term trend.....	28
Figure 2.9 Records of maximum rainfall observed in Tarakan from 1984 to 2009.....	29
Figure 2. 10 (a) Correlation between the probability of monthly rainfall exceeding certain threshold and the probability of daily rainfall exceeding 60 (blue), 80 (green) and 100 mm/day (red) with square symbol designates data of Singapore (threshold of monthly rainfall is 400 mm), while asterisk, cross, and plus symbols indicate data of Kenten (1985-1989), Kenten (1990 – 1994) and Tarakan respectively (see text);m (b)projected trend of the probability of extreme events (rainfall exceeding 433 mm).....	29
Figure 2.11 Monthly mean sea level and surface currents at the south of Sulawesi Sea near Tarakan during the peak of Asian and Australian Monsoon in January and August, respectively. ....	30
Figure 2. 12Tidal level and surface currents during the high and low tidal level at coast of Tarakan and its surrounding shallow seas. ....	31
Figure 2.13 The SST projection based on the MRI model results for the SRESA1b, A2 and B1 scenarios .....	33

Figure 2.14 Sea Level Rise Projection based on Several Models and Emission Scenarios.....	34
Figure 2.15 Time-series of significant wave height (SWH) based on Wavewatch III model results from 2000 to 2008 using the blended QuickScat and NCEP wind data.....	37
Figure 3.1 Elements of hazards induced by sea level change.....	42
Figure 3.2 Hazard Projection Modelling Process of Water Sector.....	45
Figure 3.3 Schematic of the compartment modeling of DHF.....	47
Figure 4.1 Inundation Map of Scenario-3.....	53
Figure 4.2 Vulnerability Map of Topography.....	54
Figure 4.3 Vulnerability Map of Topographic Slope.....	54
Figure 4.4 Vulnerability Map of Land Use 2010.....	54
Figure 4.5 Vulnerability Map of Land Use 2030.....	54
Figure 4.6 Vulnerability Map of Population Density 2030.....	55
Figure 4.7 Vulnerability Map of Infrastructure and Critical Facility 2010.....	55
Figure 4.8 Vulnerability Map of Infrastructure and Critical Facility 2030.....	55
Figure 4.9 Aggregate map of all vulnerability in 2008.....	56
Figure 4.10 Aggregate map of all vulnerability in 2030.....	56
Figure 4.11 Scheme for estimate the risk level.....	57
Figure 4.12 Risk Map 2030.....	58
Figure 4.13 Overlay between Hazard Map of Scenario-3 and Spatial Plan 2029.....	59
Figure 4.14 Regionalism for Adaptation in Coastal Area of Tarakan City.....	62
Figure 5.1 Flood Risk in Baseline and Projection Condition.....	65
Figure 5.2 Results of Landslide Hazard Modelling.....	67
Figure 5.3 Water Demand Calculations for Tarakan City.....	68
Figure 5.4 Map of Water Shortage Hazard.....	69
Figure 5.5 Vulnerability of Floods in Baseline and Projection Condition.....	70
Figure 5.6 Vulnerability of Landslide in Baseline Condition and Projection Condition.....	71
Figure 5.7 Vulnerability of Water Shortage in Baseline and Projection Condition. Source: Water Sector Report, Abdurrahman et al, 2011.....	72
Figure 5.8 Landslide Risk for Baseline and Projection Condition.....	76
Figure 5.9 Overlay between Landslide Risk and Land Use Map.....	77
Figure 5.10 Risk Map of Water Shortage in Baseline and Projection Condition.....	77
Figure 5.11 Adaptation Areas towards Flood Risk in Tarakan City.....	79
Figure 5.12 Area I Land Use in 2008, Land Use in 2030, and Flood Risk in 2030.....	80
Figure 5.13 Area II Land Use in 2008, Land Use in 2030, and Flood Risk in 2030.....	80
Figure 5.14 Area III Land Use in 2008, Land Use in 2030, and Flood Risk in 2030.....	81
Figure 6.1 Monthly DHF Cases in Tarakan increase following the population.....	89
Figure 6.2 Monthly DHF and Monthly Rainfall in Tarakan.....	90
Figure 6.3 Monthly DHF and Monthly Temperature in Tarakan.....	90
Figure 6.4 Relationship between monthly rainfall with DHF Cases for average 2003-2009 in Tarakan.....	91
Figure 6.5 Hazard Map of Existing DHF in Tarakan.....	92

Figure 6. 7 DHF Estimation 2003-2008 in Tarakan City by Poisson Regression.....	93
Figure 6. 6 DHF Estimation 2008-2010 in Tarakan City by Compartment Model.....	93
Figure 6. 8 Hazard Map of Existing Diarrhea in Tarakan .....	95
Figure 6. 9 Hazard Map of Existing Malaria in Tarakan .....	96
Figure 6. 10 Projection of DHF Cases 2011-2030 Based on Deterministic Model.....	97
Figure 6. 11 Hazard Map of DHF Projection 2030 .....	98
Figure 6. 12 Projection of Diarrhea Cases 2011-2030 Based on Deterministic Model.....	99
Figure 6. 13 Hazard Map of Diarrhea Cases Projection 2030.....	99
Figure 6. 14 Projection of Malaria Cases 2011-2030 Based on Compartment Model.....	100
Figure 6. 15 Hazard Map of Malaria Cases Projection 2030.....	101
Figure 6.16 Vulnerability Map of Tarakan Subdistrict toward Existing DHF .....	102
Figure 6. 17 Vulnerability Map of Tarakan Subdistrict toward Existing Malaria .....	104
Figure 6. 18 Vulnerability Map of Tarakan Subdistrict to Existing Diarrhea .....	105
Figure 6. 19 Vulnerability Map of Tarakan tSubdistrict toward DHF Year 2030.....	107
Figure 6. 20 Vulnerability Map of Tarakan tSubdistrict toward Malaria Year 2030.....	108
Figure 6. 21 Vulnerability Map of Tarakan tSubdistrict toward Diarrhea Year 2030.....	109
Figure 6. 22 Risk Map of Existing DHF in Tarakan .....	111
Figure 6. 23 Risk Map of Existing Diarrhea in Tarakan.....	113
Figure 6. 24 Risk Map of Existing Malaria in Tarakan.....	115
Figure 6. 25 Risk Map of DHF Projection in 2030 in Tarakan .....	117
Figure 6. 26 Risk Map of Diarrhea Projection in 2030 in Tarakan.....	119
Figure 6. 27 Risk Map of Malaria Projection in 2030 in Tarakan.....	121
Figure 7. 1 Coastal Inundation Risk in 2030 .....	129
Figure 7. 2 Landslide Risk in 2030 .....	130
Figure 7. 3 Flood Risk in 2030 on 3 Areas .....	130
Figure 7. 4 Dengue Fever Risk in 2008.....	131
Figure 8. 1 CCRAA Process and Mainstreaming into Development Planning in Tarakan City .....	135





## List of Tables

Table 1.1 River Basins in Tarakan .....	14
Table 1.2 Population, Area, Density and Distribution of Tarakan's Population by Village in 2010 .....	16
Table 1.3 Gross Regional Domestic Product of Tarakan in 2008 (current price).....	18
Table 2.1 Trends of surface temperature change in Tarakan throughout the last century .....	23
Table 2.2 Sea Level Rise Projections based on the Observational Data and Models .....	34
Table 2.3 ENSO Time Table based on MRI Model Output for SRESA1B Scenario.....	35
Table 3.1 Various Levels of Risk and Adaptation to Climate Change.....	38
Table 3.2 Method/Model and Parametres in Hazard Analysis .....	40
Table 3.3 Scenarios of Cumulative Hazards for SRESA1B Scenario .....	43
Table 3.4 Indicators for Vulnerability Assessments.....	48
Table 3.5 Chart for Risk Analysis .....	50
Table 4.1 Elements of Hazards Related to Sea Level Changes .....	51
Table 4.2 Elements of Hazards Related to Sea Level Changes for SRES A1B .....	52
Table 4.3 Inundated area, distance, and shoreline in selected villages in which having largest and second largest coastal inundation hazard impacts in 2030.....	53
Table 4.4 An aggregate and weighting of all vulnerability elements .....	56
Table 4.5 Summary of Risk Map in Selected Villages Year 2030 .....	59
Table 4.6 Summary of Adaptation Strategies in Selected Villages .....	62
Table 5. 1 Flood Hazard Area of Tarakan .....	64
Table 5. 2 Floodplain Area in Projection Hazard of Tarakan.....	65
Table 5. 3 Weighting of Vulnerability Component for Flood Hazard .....	70
Table 5. 4 Weighting of Vulnerability Component for Flood Hazard .....	71
Table 5. 5 Weighting of Vulnerability Component for Flood Hazard .....	72
Table 5. 6 Flood Risk Profile in Tarakan City based on Watershed.....	73
Table 5. 7 Landslide Probability for 2011 – 2020 and 2021 – 2030 Projection .....	75
Table 5. 8 Summary of Adaptation Options in Water Sector.....	78
Table 5. 9 Recapitulation of Adaptation Strategies for Anticipating Flood Risk in Tarakan City.....	82
Table 5. 10 Works Typology of Landslide Stabilization.....	83
Table 5. 11 Adaptation Option on Landslide Area.....	84
Table 5. 12 Summary of Adaptation to Water Shortage.....	86
Table 6.1 Existing Hazard Categorization for DHF in Tarakan City .....	91
Table 6.2: Diarrhea cases in Tarakan 2000-2010 .....	94
Table 6. 3 Existing Hazard Categories of Diarrhea in Tarakan City.....	94
Table 6.4 Malaria cases in Tarakan 2007-2009 .....	95
Table 6.5: Existing Hazard Categories of Malaria in Tarakan .....	95
Table 6.6 Categories of DHF Hazard in 2030 .....	98
Table 6.7 Categories of Diarrhea Hazard in 2030.....	100
Table 6.8 Hazard Categories of Malaria in Tarakan City for 2030 .....	101
Table 6. 9 Level of Existing Vulnerabilities to DHF in Tarakan City .....	103

Table 6. 10 Vulnerability Scores for Existing DHF, Malaria and Diarrhea in Tarakan.....	105
Table 6. 11 Vulnerability Score for Future DHF in Tarakan (Year 2030) .....	106
Table 6. 12 Vulnerability Scores for Future Malaria in Tarakan (Year 2030) .....	107
Table 6. 13 Vulnerability Scores for Future Diarrhea in Tarakan (Year 2030) .....	108
Table 6. 14 Existing Hazard, Vulnerability and Risk to DHF in Tarakan City .....	110
Table 6. 15 Factors Influence the Risk Score 2008 in SubdistrictSubdistricts with Very High Risk Score of DHF .....	111
Table 6. 16 Existing Hazard, Vulnerability and Risk to Diarrhea in Tarakan.....	112
Table 6. 17 Factors Influence the Risk Score 2008 in SubdistrictSubdistricts with Very High Risk Score of Diarrhea .....	113
Table 6. 18 Existing Hazard, Vulnerability and Risk to Malaria in Tarakan.....	114
Table 6. 19 Factors Influence the Risk Score 2008 in Tarakan villages with High Risk Score of Malaria .....	115
Table 6. 20 Risk Level of DHF Projection for Year 2030 in Tarakan.....	116
Table 6. 21 Factors Influence the Risk Score 2030 in SubdistrictSubdistricts with Very High Risk Score of DHF .....	117
Table 6. 22 Risk Level of Diarrhea Projection for Year 2030 in Tarakan .....	118
Table 6. 23 Factors Influence the Risk Score 2030 in SubdistrictSubdistricts with Very High Risk Score of Diarrhea .....	119
Table 6. 24 Risk Level of Malaria Projection for Year 2030 in Tarakan .....	120
Table 6. 25 Factors Influence the Risk Score 2030 in Tarakan villages with High Risk Score of Malaria .....	121
Table 6. 26 Adaptation Strategy of DHF in Tarakan City .....	123
Table 6. 27 Adaptation Strategy for DHF for Each Category in Tarakan .....	124
Table 6. 28 Adaptation Strategy Category of Malaria for Each Village in Tarakan.....	125
Table 6. 29 Adaptation Strategy for Malaria for Each Category in Tarakan.....	126
Table 6. 30 Adaptation Strategy Category of Diarrhea for Each Village in Tarakan.....	127
Table 6. 31 Adaptation Strategy for Diarrhea for Each Category in Tarakan.....	127
Table 8. 1 Contents of Tarakan City RPJP Related to CCRAA .....	136
Table 8. 2 Key Points on RPJP Guidance for RPJM 2010 – 2014 and Its Relation with CCRAA.....	137
Table 8. 3 Issues Addressed by RPJM 2010 – 2014 and Its Possible Relation with CCRAA.....	139
Table 8. 4 RPJM Development Mission, Goals, and Strategies which has Relation with CCRAA.....	139
Table 8. 5 Tarakan City RPJM Development Policy and Program 2010 – 2014....	140
Table 8. 6 Compatibility Measurement between RTRW Tarakan City Development Program and Adaptation Strategy in Coastal and Water Sectors .....	141
Table 8. 7 Example of Compatibility in Coastal Sector of Tarakan City .....	145
Table 8. 8 Example of Compatibility in Water Sector of Tarakan City.....	147
Table 8. 9 Example of Compatibility in Health Sector of Tarakan City.....	149
Table 8. 10 Example of Synchronization Result in Coastal Sector of Tarakan City.....	150
Table 8. 11 Example of Synchronization Result in Water Sector of Tarakan City.....	150
Table 8. 12 Example of Synchronization Result in HealthSector of Tarakan City.....	151

# 1. Description and Strategic Issues of Tarakan

## 1.1 *Physical conditions*

### 1.1.1 Geographical and Geological Setting of Tarakan City

The island of Tarakan is located off the north-east coast of Kalimantan, approximately 3°.19'-3°.20' N and 117°.34'-117°.38' E. The total area of Tarakan City, consists of land and sea and measures 657.33 km<sup>2</sup>. Towards the North, Tarakan City borders Bunyu Island and the Sulawesi Sea to the East; Tanjung Palas to the South; and Kalimantan and Sesayap Subdistrict to the West. Tarakan is approximately 20 km long from North to South and 10 km wide from East to West. Tarakan shows a considerable diversity of coastal morphology, exposures, and ecosystems. Current data shows that almost 80% of Tarakan's population lives in the coastal region less than 2 km inland and highly concentrated in the south-west of the island, where economic and government activities have been concentrated. In terms of topographical features, Tarakan consists of a hilly ridge in the middle of the island which extends from the North coast to the South coast with an elevation varying between 60 and 90 metres, where the maximum height is about 100 metres. On the either side, the topography shows mild slopes towards the east and west coasts and on the east coast this slope continues down to the sea bed.

A strait between Kalimantan and Tarakan shows signs of an ancient river which runs southwards parallel with the coastline. The water depth has been measured between 6 and 9 metres, then as it turns eastwards toward the Sulawesi Sea, the water depth increases to approximately 25 – 40 metre with the channel width around 1.5 km. To the north of Tarakan, the bathymetry also shows that the river channel flows from the inland areas of Sasayap Lama, with a depth between 5 and 10 metres. In addition, towards the Sulawesi Sea, the depth then varies between 7 and 14 metres, with a channel width around 1 km. As the bathymetry in the eastern part of Tarakan is very gentle and continuous up to the continental edge of Kalimantan, the water depth in eastern Tarakan is very shallow varying between 2 and 6 metres below MSL, at least up to 10 km from the coastline.



Figure 1.1 Location of Tarakan and its surrounding areas (*source: Googlemap*)

Prior to examining geological conditions, it is important to identify the morphological conditions. Simply put, the morphology of a site is a qualitative description of the site's land form along with a quantitative description of its slopes. These physical conditions will enable estimates regarding coastal flooding and erosion. The nature of its slopes could be one of the physical vulnerability components of the city. In general, Tarakan consists of flatland or plain and surrounded by coastal part and highland which is distributed from the North to the South in the middle of the island. The morphology of the site is divided into 3 (three) units as follows:

1. *Flatland or plain*. This plain is formed by coastal alluvial sediments (mud, silt, sand, gravel and coral) and usually located in coastal areas. It is a relatively flat area with fine relief (1-2 m), low elevation (0-10 m above sea level/m.asl), and slopes less than 5%;
2. *Wavy terrain*. This unit is formed by the Sajau Formation (quartz sandstone, clay stone, siltstone, coal, lignite, and conglomerate) and can be found in the western, southern, and eastern part of the island. It is relatively flat with a rough relief between 1-5 m in low elevation (10-25 m asl) and 5 to 10% slope;
3. *Hills*. It has fine coarse reliefs (5-50 m) at an elevation of 25-100 m ASL and a slope of 5% to more than 15%. Characterized by rocks of Sajau Formation lithologies and a river flow of sub-dendritic and sub-parallel pattern sand with a partly seasonal flow.

In terms of geological composition, the city consists of Sajau Formation, which is comprised of older, consolidated rocks, and an alluvial unit which is younger and mostly unconsolidated rock. Vertically and laterally these two major units' areas are comprised as follows:

1. *Alluvium unit*. This unit consists of mud, silt, sand, gravel, and coral. These rocks are sediment products in coastal, rivers and swamps depositional environment rock and distributed over the western and eastern regions of Tarakan;
2. *Sajau Formation*. This formation consists of quartz sandstone, clay stone, silt stone, coal, lignite, and conglomerate. It is Plio-Pleistocene- aged sediment and is deposited in a fluvial to delta environment with a thickness of 600 - 2000 metres. Its distribution is located in the north, central, and southern regions of the site.

In general, the geological condition of Tarakan City consists of: (1) Claystone, Sajau Formation (light brown-coloured), (2) Sandstone, Sajau Formation (very light brown-coloured), (3) Coal, Sajau Formation (darker brown-colored), (4) Quarter deposits or Alluvial units (darker orange-colored), (5) Conglomerate, Sajau Formation (orange coloured), (6) Monmorilonite clay, Sajau Formation (darker tan-coloured), and (7) Argillaceous sand, Sajau Formation (brown colored). The geological structures of the site are bedding, faults, folds or anticline, and rock joints. In general, the fault trend of the west-east axis dip cut is an anticline and fault lithology of Sajau Formation. The old structures are anticline and syncline, elongated from the north to the south of the axis direction. The structure can be found in rocks that are strongly folded. Based on the geological conditions, it can be predicted that unit and Sajau formation alluvium rocks are more vulnerable to abrasion due to wind waves and inundation from a rise in sea level compared to the coastal rock and sand materials.

As Tarakan is an island city, the coastal area is a strategic location for almost all of the city's interests; e.g. location for settlement, access to transportation, a source of economic development and livelihood, ecosystem services, etc. The coastal area defined here is a band of dry land, adjacent to an open space of water and submerged land, in which terrestrial processes and land use directly affects oceanic processes and uses, and vice versa. The coastal area of Tarakan has several contrasting situations in terms of land utilisations. For instance, in the south-western coasts, it is intensively developed for urban activities, port, industry, fishing and oil exploitation activities. On the other side, the eastern and northern coasts have a low population density and have well-preserved ecosystems which have recently become a focus for seaside tourist resorts.

Other very important geographical components for Tarakan City are the river and watershed conditions. In general, the type of river to be found in Tarakan is the intermittent river, which means dry or low flow in the dry season; and abundant flow to flood in wet season. Even though the patterns of river flows are mostly semi-radial in the northern center of the island, it was found that parallel patterns also existed for some regions in the East, South-east, and West. Several big rivers are also correlated with dense forests; i.e. Binalatung River, Pamusian River, Kuli River, Bengawan River, Raja Alam River, and Kampung Bugis River. The river discharge ranges from 19 to 290 liters/second or equal to 0.019 to 0.29 m<sup>3</sup>/second.

In some rivers, reservoirs or *embung* are developed as a source of water supply for Tarakan City. The water within the reservoirs themselves come from riverflow and rainfall. The capacity of the reservoirs varies from 0.155 m<sup>3</sup>/second at the nursery area, 0.006 m<sup>3</sup>/second in Kampung Bugis, and 0.030 m<sup>3</sup>/second in Juata Laut. A

factor that affects the rivers is the fact that there are 24 watersheds (DAS, *Daerah Aliran Sungai*) in Tarakan City. In the waterworks planning of Tarakan Public Works Agency (*Dinas PU*), rivers are used as the primary drainage, and the drainage system is divided based on river flows. The following table shows the list of river basins in Tarakan.

Table 1.1 River Basins in Tarakan

No.	Rivers	River Basin Area (Ha)	Discharge (m <sup>3</sup> /s)
1	Maya	15,066	1.316
2	Mangantal	10,422	910
3	Selayung	8,336	731
4	Siaboi	20,492	1.789
5	Simaya	17,245	1.506
6	Hanjulung	6,634	579
7	Binalung	22,591	1.973
8	Kuli	4,268	373
9	Slipi	3,821	334
10	Amal Baru	3,468	303
11	Batu Mapan	3,138	274
12	Mentogog Kecil	1,441	126
13	Tanjungbatu	2,025	177
14	Mentogog	4,944	432
15	Karungan	7,054	616
16	Nangitan	2,336	204
17	Pamusian and Buaya	23,820	2,080
18	Kampung Bugis	5,641	493
19	Sesanip	6,676	583
20	Persemaian	14,779	1,290
21	Bengawan	12,363	1,080
22	Belalung	9,737	850
23	Bunyu	7,575	662
24	Semunti Besar and Semunti Kecil	8,976	784

Source: Dinas PU Pengairan Kota Tarakan, 2009.

High rainfall and physical properties of soil in many vacant lands make it easily eroded, causing high sedimentation in some rivers. The quality of the water from the rivers was good enough to be consumed after treated using activated carbon and filtering. Swamps located in low lands store a noticeable quantity of water. The water within the swamps is acid, thus it is not suitable as a source of drinking water.

Groundwater fills pores or fissures inside rock. Rock layers or rock formations that are able to store and drain water (groundwater) in significant quantities is called "aquifer". These aquifer systems consist of unconfined aquifer and confined aquifer, and spring as appearance of groundwater flow at the surface. There are only two types of groundwater potential in Tarakan. The first is low potential groundwater, which is distributed mostly in high topography. The second is moderate potential groundwater, which is distributed over the plain areas. There is no high potential groundwater in Tarakan.

### 1.1.2 Physical Development Growth in Tarakan City

Physical development in Tarakan City cannot be separated from its history and how the name of “Tarakan” was given to the location. Based on local history, the word “Tarakan” came from the Tidung Language; i.e. *Tarak* (to meet) and *Ngakan* (to eat). Therefore basically old Tarakan was the settlement location where fishermen would meet, eat, and trade their products related to fishery. These activities formed the basis of old Tarakan which is located on the west coast of Tarakan City.

The RTRW of Tarakan City (General Spatial Plan) divides Tarakan City into two service areas, both having city centers; i.e. Old City Centre, is assigned to serve West, Middle, and East Tarakan Subdistrict; and New City Centre for northern Tarakan which will serve as the centre of government activities. The service area is determined based on its development growth. In this sense, the Old City Center was the location of very dense building whereas the New City Center was projected to be a future growth centre, but for now it is still undeveloped.

In term of its physical development stages and direction, Tarakan City grew in a north – south direction, mostly along the west coastal area. This can be seen from the previous arterial road system and locations of vital infrastructure located along the west coast. Current growth and future directions are given by the RTRW of Tarakan City, which indicates that the physical growth will be pushed more towards the north–east. This intention can be seen from the Spatial Structure of Tarakan City, where it was planned for the city to have a ring road so that the island can be accessed from all directions. In addition, the decision to put Government Offices on the North side of Tarakan along with 4 new Sub City Centers on the north and east coasts is also proof of its intentions for physical growth. Therefore, the direction of other utilities, e.g. energy, telecommunication, drainage, clean water, etc, are also being planned to be roughly parallel with the road system, in the sense that it may facilitate economic activities and settlement area throughout Tarakan City.

The land utilisation data from 2008 confirms that the size of the conservation area is 8.505,32 Ha, while the developed and utilised area is 16.561,66 Ha. Based on the RTRW of Tarakan City, by the end of 2030, it is planned that the size of the conservation area (consisting of preservation forest, mangrove forest, city forest, and other green open space) should increase up to 15.350,20 Ha;. On the other hand, the size of the utilised area (consisting of settlement, commerce and services, defense, airport, business area, education, industry, tourism, mining, agriculture, and other utilities) will be decreased to approximately 9.729,80 Ha;. It can be inferred that within the next 20 Tarakan City years will direct itself into a more compact development. However, these plans have little impact on the morphology of the city. From the Spatial Pattern Map given in the RTRW of Tarakan City 2011 – 2030, it can be seen that the development of utilised areas in Tarakan City would surround the inner preservation forest. The existing densely built-up area on the west coast has been planned to be retrofitted. It will have countermeasures, in which the the future government centre will be located in north side, followed by settlement and other supporting urban activities. Industrial areas will be located in the north towards the east of Tarakan City. As for the east coast, it will be designated as a mid-dense settlement and tourism area.

## 1.2 Socioeconomic conditions

### 1.2.1 Population

The population of Tarakan based on the Census 2010 is 193.069, which is a large increase from the figure of 116.995 registered in 2000. The population growth rate between Census 2000 and 2010 is 6,50% per year, which is well above national the growth rate of 1,49% per year during the same period (BPS Kota Tarakan, 2010). Major concentrations of Tarakan's population are in the villages of West Tarakan subdistrict, especially Karang Anyar and Karang Anyar Pantai. However, the village with the highest population density is Selumit Pantai (340 per hectare), in Central Tarakan tsubdistrict. Meanwhile, the tsubdistrict with the fastest growth rate is North Tarakan subdistrict. Thus, while Central and West Tarakan have historically been the major areas for settlement, North Tarakan is growing to be a major settlement area in Tarakan. The table below shows the population, density and distribution by each tsubdistrict and village, based on the Population Census 2010. Figure 1.2 below shows the population density map in 2010 based on the population distribution within the settlement. Thus it gives a more realistic population density profile.

Table 1.2 Population, Area, Density and Distribution of Tarakan's Population by Village in 2010

Subdistrict/ Village	Population	Area (sq km)	Density (km <sup>2</sup> )	Distribution (%)
<b>East Tarakan</b>				
Lingkas Ujung	10,409	1.16	8,973	5.39
Gunung Lingkas	7,905	3.19	2,478	409
Mamburungan	7,633	8.51	897	3.95
Kampung Empat	4,529	11.39	398	2.35
Kampung Enam	5,433	11.21	485	2.81
Pantai Amal	4,469	12.15	368	2.31
Mamburungan Timur	2,531	10.40	243	1.31
<b>Central Tarakan</b>				
Selumit Pantai	16,347	0.48	34,056	8.47
Selumit	6,490	0.43	15,093	3.36
Sebengkok	15,019	1.48	10,148	7.78
Pamusian	14,131	2.54	5,563	7.32
Kampung 1 Skip	8,410	50.61	166	4.36
<b>West Tarakan</b>				
Karang Rejo	6,856	0.76	9,021	3.55
Karang Balik	7,875	0.80	9,844	4.08
Karang Anyar	27,573	5.61	4,915	14.28
Karang Anyar Pantai	17,855	8.51	2,098	9.25
Karang Harapan	7,621	12.21	624	3.95
<b>North Tarakan</b>				
Juata Permai	6,877	14.23	483	3.56
Juata Kerikil	4,705	10.59	444	2.44
Juata Laut	10,401	84.54	123	5.39



Subdistrict/ Village	Population	Area (sq km)	Density (km <sup>2</sup> )	Distribution (%)
City of Tarakan	193,069	250.80	770	100.00

Source: BPS Kota Tarakan, 2010, p. 9

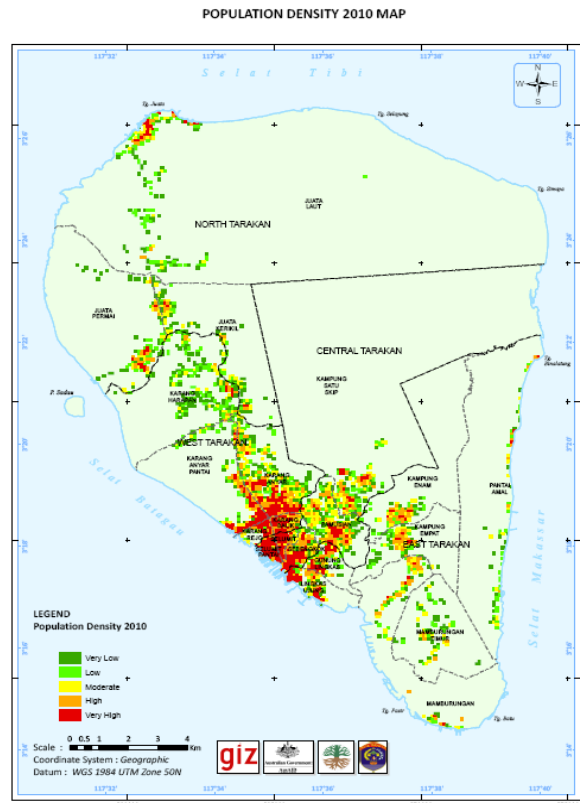

Figure 1.2 Map of Population Density in Tarakan City

## 1.2.2 Livelihood

Most people in Tarakan work as fishermen, crop growers, factory workers, or in business and services, which are scattered around the island as described below (Tarakan City Development Planning Agency/Bappeda, 2011):

1. Fishermen activities, mostly in North Tarakan subdistrict and Karanganyar Pantai (West Tarakan).
2. Crops and agrarian activities are scattered throughout North Tarakan, Central Tarakan and East Tarakan subdistricts.
3. Factory workers are employed in industrial zones around the island.
4. Business and services activities tend to take place in the old part of the city, such as: Karanganyarpantai, Karanganyar, Karangrejo, Karangbalik villages in the West Tarakan subdistrict; Selumit Pantai, Selumit, Sebengkok villages in Central Tarakan subdistrict; Lingkasujung, Gununglingkas, Pamusian, and Mamburungan villages in East Tarakan subdistrict.

## 1.2.3 Economic Structure

The economy of Tarakan, measured by Gross Regional Domestic Product (GRDP) in 2008 Rp. 5.24 trillion (with oil and gas) or Rp. 4.77 trillion (without oil and gas).

This is the equivalent of US\$ 582 million, or US\$ 530 million, respectively (where US\$1 = Rp. 9,000). The economy is dominated by trade, and the hotel and catering sectors, which contribute 38.14% of total GRDP in 2008. Out of that, the trade subsector is actually the major contributor with 36.34%. Then in 2<sup>nd</sup> place, the manufacturing sector contributes 15.27% of the economy (Bappeda Kota Tarakan, 2011). The agriculture sector contributes 11.30% of the economy putting it in 3<sup>rd</sup> place. Out of this the fisheries subsector contributes 7.45%, in other words a major contributor to the agriculture sector. The value of GRDP of each sector and its share in the economy is depicted in the table below.

Table 1.3 Gross Regional Domestic Product of Tarakan in 2008 (current price)

Economic Sector	Amount (Rp. Million)	Share (%)
Agriculture	591,744	11.30
- Fisheries	390,279	7.45
Mining and quarrying (with oil and gas)	493,597	9.42
- Oil and gas	464,574	8.87
Manufacturing	799,850	15.27
Electricity, water and gas	91,978	1.76
Construction	197,009	3.76
Trade, hotel and restaurant	1,998,016	38.14
- Trade	1,903,679	36.34
Transportation and communication	456,952	8.72
- Air transportation	184,871	3.53
Financial services	326,639	6.24
Government and other services	282,399	5.39
- Government	235,670	4.50
Total (with oil and gas)	5,238,185	100.00

Source: modified from Bappeda Kota Tarakan, 2011, p. 102

### 1.3 Strategic Issues

Strategic issues in the development of Tarakan City can basically be inferred through over the reading of strategic documents that assign several objectives for Tarakan City; i.e. from national and provincial level, as well as internal Tarakan City development plan documents, both from the spatial and non spatial perspectives. In addition, strategic issues can also be understood from the field observation and discussion with staff of Tarakan City Government.

From the macro perspective, based on Government Regulation 26/2008 regarding the National General Spatial Plan (RTRW Nasional), Tarakan City is being assigned as a Center of National Activities (PKN). Therefore, there will be several objectives being given to Tarakan, as well as a specific development agenda, in addition to the development of its designated service area to include the surrounding area of Tarakan City. As a PKN, Tarakan City is being assigned as one of Tatapanbuma Key Region (*Kawasan Andalan Tarakan, Tanjung Palas, Nunukan, Pulau Bunyu, dan Malinau*); thus there will be enhancement for key infrastructure development in

Tarakan City; i.e. Tarakan Sea Port and Juwata International Airport. The assignment to become PKN will accelerate development in Tarakan City.

The regional perspective of Tarakan City's development, which has shaped its strategic issues, can be derived from the Kalimantan Island Spatial Plan (RTR Kalimantan) and General Spatial Plan of East Kalimantan (RTRW Kalimantan Timur). Both documents basically tried to bridge national and regional interests for Tarakan City, in the sense that it details guidance for Tarakan's development as a PKN. Tarakan City is being prepared as a new centre for development and growth in the northern part of Kalimantan Island, which has two functions; i.e. to reduce development gaps in northern-east Kalimantan as well as to compete regionally with all the neighboring countries. Therefore, through summarising both documents, there is a specific development agenda for Tarakan as follows: a) development of Tarakan as a centre for oil and natural gas mining activities, b) development of a primary road that connects Tarakan Sea Port and Airport, c) internationalization of Tarakan Sea Port, d) development of an electrical power plant to support mining activities, e) development of a telecommunications network integrated with the national system, f) positioning of Tarakan City as a National Defense and Security Base, and g) development of industrial activities, which spans from chemical, plantation, fisheries, timber, shipyard, and workshop industry.

On the other hand, from the internal perspective, Tarakan City has stated that the long term development vision sees Tarakan City as a Commercial and Service Centre to Achieve a Prosperous Society in Sustainable Environment". The vision is thus being detailed through a series of long, medium, and short term missions, strategies, and government programs; which basically aims to give prosperity to the people of Tarakan. However, the Strategic Environmental Assessment (KLHS) of Tarakan City has reported that there are several issues regarding the balance between development and environment as follows: a) domination of land use in terms of built-up areas, economic activities, and population density in the old part of the city, b) limited capacity of land and environment to support development, c) accessibility that is heavily oriented towards the old part of the city, and d) inequity in terms of infrastructure and the distribution of economic development.

Impact of climate change being discussed in this study; i.e. around the coastal area, water resources, and health, would basically add environmental pressure to the city and its environmental services to support its utilisation for development. On the other hand, there are massive development programmes that will be carried out in Tarakan that add more vulnerability. Thus the risk of impact of climate change in all respective sectors will increase. However, it should also be noted that development which takes into consideration the risk of impact of climate change, can thus be prepared for the adaptation which will give the city the capacity to become resilient. Furthermore, here are the strategic issues of sectors in CCRAA context for Tarakan City:

- The active and complex coastal area dynamics leads to shoreline erosion and sedimentation in the Tarakan coastal zone. Erosive processes have narrowed the beaches in Tarakan City, for instance, in the east coast, successive erosion events have constantly affected residents' life.

- Land use change planned by the RTRW of Tarakan City may increase vulnerability to the impact of climate change in coastal areas; e.g. the highly dense and developed west coast and initiatives to develop tourism activity on the east coast. Tarakan has geographic disadvantages as a small island, thus the city is prone to climate changes, particularly from a rise in sea level, tropical monsoon, torrential flooding and prolonged drought. The isolation of Tarakan from mainland Kalimantan Timur province has also the disadvantage of being cut off from livelihood supplies, should a climate emergency occur.
- Regarding the population and socio-health aspects, population density made worse by the influx of job-seeking, incoming migrants will burden the health infrastructures. Socially, there will be tension between the slum-dwelling migrants and the local inhabitants. Racial tension may soar.

## **2. Supporting Scientific Data**

The supporting scientific data analysis upon which this climate change risk and adaptation assessment has been developed is most significant as it provides information regarding what kind of climate changes may typically occur in Tarakan. This analysis includes analysis and projections of climate change and sea-level rise as well as extreme events occurring in atmosphere and coastal waters of this small island.

### ***2.1 Analysis and Projection of Climate***

#### **2.1.1 Mean Annual Pattern of Rainfall and Temperature in Tarakan**

In general, Tarakan has a humid tropical climate with relative humidity as high as 87% during the driest month. Tarakan also lies in the monsoon region where near surface winds generally reverse direction about every six months, preceding the onset of alternating drier and wetter seasons. Although affected by such annual variation of monsoon circulation, the rainfall in Tarakan is normally always higher than 240 mm for each month with an average value of about 310 mm (Figure 1.1). In Tarakan, the dry season does not well develop in normal years because rainfall amount in the “driest” month of February is still typically as high as about 250 mm. The rainfall in Tarakan is of equatorial-type, which can be identified from the two peaks around April (boreal spring) and November (the end of boreal fall).

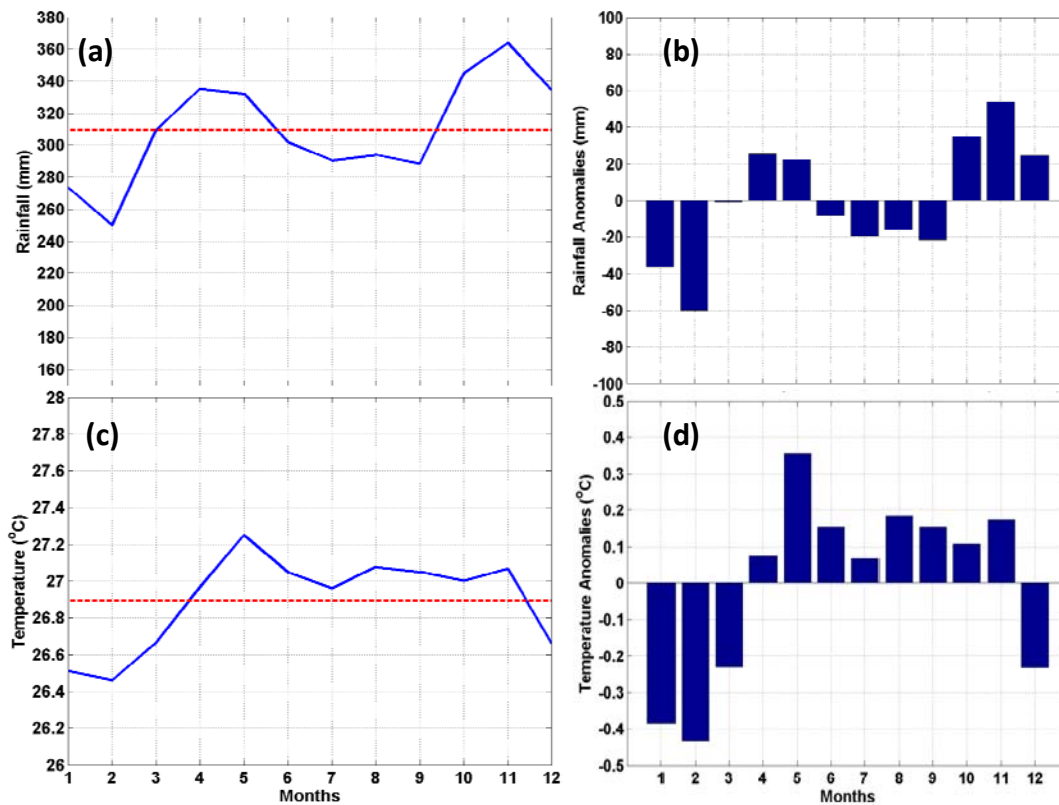

Figure 2.1 Mean annual variation of monthly (a)rainfall and (c)temperature, while (b) and (c) show the corresponding anomalies relative to long-term average as indicated by the red dashed lines.

From Figure 2.1, it can also be seen that the long-term mean temperature in Tarakan is around 26.9°C with less than 1°C variations between different months. Peaks in temperature data that are supposed to be corresponding to March and September equinoxes, are less clear probably due to the effects of cloud shading on surface temperature measurements. It is of interest to note that February is the “coldest” as well as “driest” month in Tarakan probably because there are predominant easterly winds that bring cooler air originated from the winter hemisphere.

### 2.1.2 Historical Climatic Hazards: Trend, Variability, and Extremes

Climatic change may be manifested by the changes in two main statistical parameters, namely *mean* and *variance*, of any weather/climate variables observed throughout at least two consecutive climatic periods. By WMO definition, a climatic period is defined as 30 years time span. In addition, secular change in surface temperature is always of interest to analyze in conjunction with global warming issue. Figure 2.2 shows long-term fluctuations in surface temperature observed over Tarakan with three trend lines calculated for the last 25, 50, and 100 years. During the last 25 years, there is a significant increase of about 0.63°C but for the last 50 and 100 years, the linear increase is only about 0.2°C/century.

Table 2.1 shows the trend of surface temperature change in Tarakan throughout the last century calculated for every month of the year. It can be seen that the trend of temperature change is different for each month with the highest value of about

0.35°C in March-April-May for the 100-year period. The increasing trend of surface temperature is, in general, well defined for the months of February to June with values between 0.2 and 0.35 °C/century. During these months, temperature measurements may be less affected by cloud shading because cloud formation is more dominated by local processes. Thus, temperature changes in March to May are likely to be influenced by the effect of the urban heat island. During the other months (July-January), larger-scale cloud systems seem to develop more frequently due to the stronger effect of the Asian monsoon.

In statistical terms, across the climatic periods, the average trend of observed surface temperature change in Tarakan is around 0.2°C/century. For the last 25 years (less than one climatic period), trends of temperature increase are in the excess of 0.4°C for all months with the highest value of about 0.84°C in July and November. Linear extrapolation of the temperature trend to the future is subject to uncertainty because there was more than 1°C fluctuation in the past data. Moreover, there is only one single station in Tarakan that provides a long-term record of temperature. Nevertheless, these data show that warming has possibly been intensified during the last several decades.

Indifferent with analysis to temperature, trend analysis is not suitable for identifying the hazard of rainfall change because long-term fluctuation in rainfall data is much larger compared to the secular trend. In the case of Tarakan, the calculated trend is only about 10 mm/century, which is insignificant compared to the total variance of rainfall data. Therefore, the hazard of rainfall change is better analyzed in terms of inter-annual and inter-decadal variabilites as discussed below.

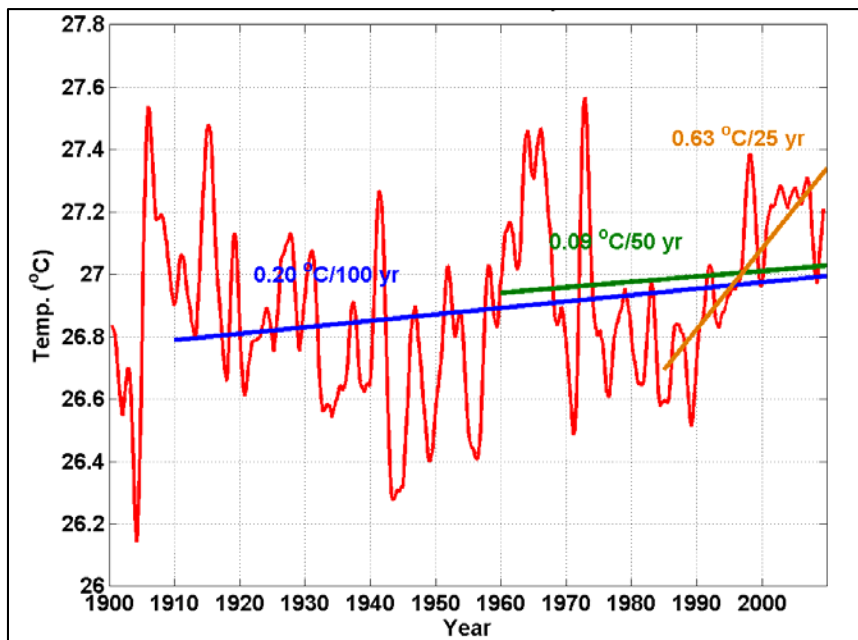

Figure 2.2 Trends in temperature changes in Tarakan over the past century. Red solid line is smoothed monthly temperature data, while blue, green, and orange lines indicate linear trends for the last 100, 50, and 25 years respectively.

Table 2.1 Trends of surface temperature change in Tarakan throughout the last century

Month	Jan	Feb	Mar	Apr	May	Jun	Jul	Aug	Sep	Oct	Nov	Dec
Trend (°C/100 yr)	0.17	0.15	0.33	0.35	0.37	0.24	0.11	-0.01	0.12	0.15	-0.06	0.10
Trend (°C/50 yr)	0.19	0.45	0.13	0.12	0.33	0.07	-0.08	-0.03	-0.33	0.01	-0.24	0.08
Trend (°C/25 yr)	0.80	0.82	0.45	0.46	0.56	0.44	0.84	0.75	0.67	0.56	0.84	0.65

### 2.1.2.1 Inter-annual Rainfall Variability

In the tropics, rainfall variations at inter-annual time scale are known to be largely affected by global climatic phenomena known as *El Niño Southern Oscillation* (ENSO) and *Indian Ocean Dipole* (IOD). These phenomena are related to the dynamic behavior of the Pacific and Indian Ocean, which are manifested as temporal and spatial variations in Sea Surface Temperature (SST). Indices that represent the climatic events associated with ENSO and IOD have been developed based on SST measurements. Scatter plots in Figure 1.2 show the correlation between ENSO and IOD indices with Standard Precipitation Index (SPI) of Tarakan. SPI is one of the simplest indices to represent drought level based on certain statistical distribution of rainfall observed at a specific location. Thus, SPI signifies the deviation of rainfall amount during a period of time (one-, three-, six-, twelve-monthly, and so on) from its local long-term mean. In Figure 1.2, six-monthly SPI values are presented with more negative (less than -0.9) SPI means more severe drought event.

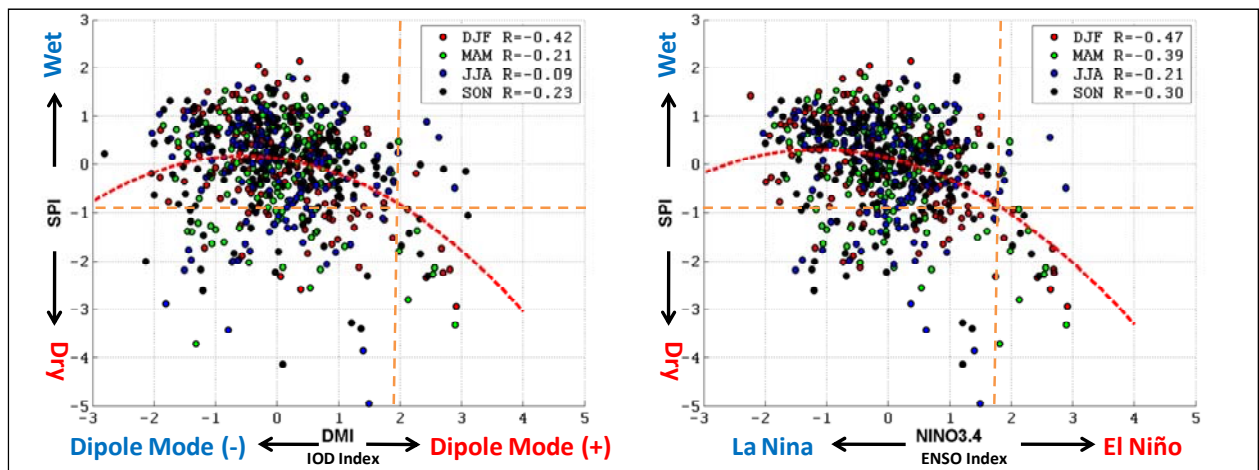

Figure 2.3 Correlation between 6-monthly Standardized Precipitation Index (SPI) calculated from rainfall of Tarakan and Dipole Mode Index (DMI)(left) as well as ENSO index (Nino3.4 sea surface anomaly)(right).

From the trend of SPI versus ENSO and IOD indices, it can be seen in Figure 2.2 that drought events at Tarakan are mostly attributed to strong El Niño, while correlation between SPI and IOD is much weaker especially for the months of June-July-August. This result is consistent with the fact that Tarakan is close to the

Western North Pacific Monsoon (WNPM) region so that effects of dynamic processes in the Pacific Ocean on the climate of Tarakan are naturally stronger compared to that of the Indian Ocean. In this case, it is assumed that the strength of ENSO is represented by the absolute value of its index. However, it should be noted that stronger La Niña events are not necessarily associated with the wettest climate conditions. When both ENSO and IOD are weak, the climatic state spreads between dry and wet conditions indicating higher uncertainty. To summarize, a strong El Niño event is one of the potential climatic hazards for Tarakan that are associated with the occurrence of drought. On the other hand, strong La Niña events do not clearly signify extreme “wetness” level. In addition, neutral (weak ENSO and IOD) events imply more uncertainties on rainfall.

ENSO is a quasi-periodic phenomenon, by which the state of the Pacific Ocean swings between cool (La Niña) and warm (El Niño) phases. El Niño may occur every two to five years and recent investigations suggest that El Niño frequency tends to be higher. However, data for the past one and a half centuries indicate that strong El Niño events, which may cause severe drought only reoccur about once in every 20 years. The impact of more frequent changes between El Niño and La Niña will be more likely associated with frequent occurrence of the neutral state, in which rainfall conditions of Tarakan maybe more unpredictable.

#### **2.1.2.2 Inter-decadal Variations of Rainfall and Temperature**

Rainfall variations at the inter-decadal time scale are quite important because, as previously mentioned, a climatological period is defined by WMO as a 30-year time window. Recent studies indicate that two oceanic variations known as Pacific Decadal Oscillation (PDO) and North Atlantic Oscillation (NAO) may influence the climate in Asia and Australia at an interdecadal time scale. Figure 2.4 shows the time series of smoothed monthly rainfall observed at Tarakan from 1911 to 2009. The interdecadal variation in Tarakan rainfall is quite pronounced during 1950 to 1980 period, which is marked by a significant decrease in decadal average rainfall during 1960 to 1970. This decreasing pattern of rainfall was not only found in Tarakan, but also appeared in most regions of East Kalimantan.

Scientific explanation for the decadal rainfall anomaly is beyond the objectives of this study but it is of interest to note that the decrease of rainfall during 1960 to 1970 only occurred in a particular season. As it is shown in Figure 2.5, results of further analysis of rainfall and temperature data indicate that the decadal scale reduction of rainfall in Tarakan occurred most significantly in the months of June-July-August (JJA), while there were only relatively little changes in the rainfall of December-January-February (DJF). Figure 2.5 also indicates the correlation between temperature and rainfall data. By the time rainfall decreases, temperature tends to increase because there are less effects of cloud shading.



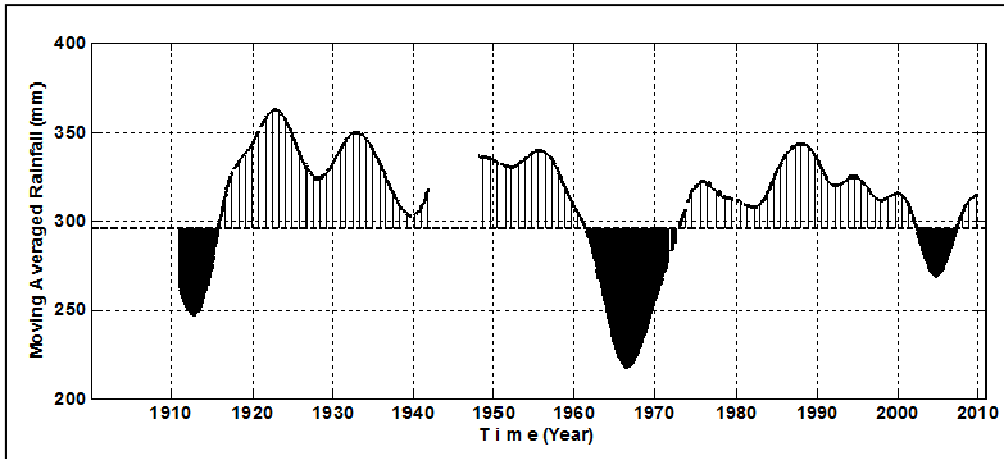

Figure 2.4 Smoothed time series of monthly rainfall observed in Tarakan from 1911 to 2009. Large gap between 1940 and 1950 indicates missing data.

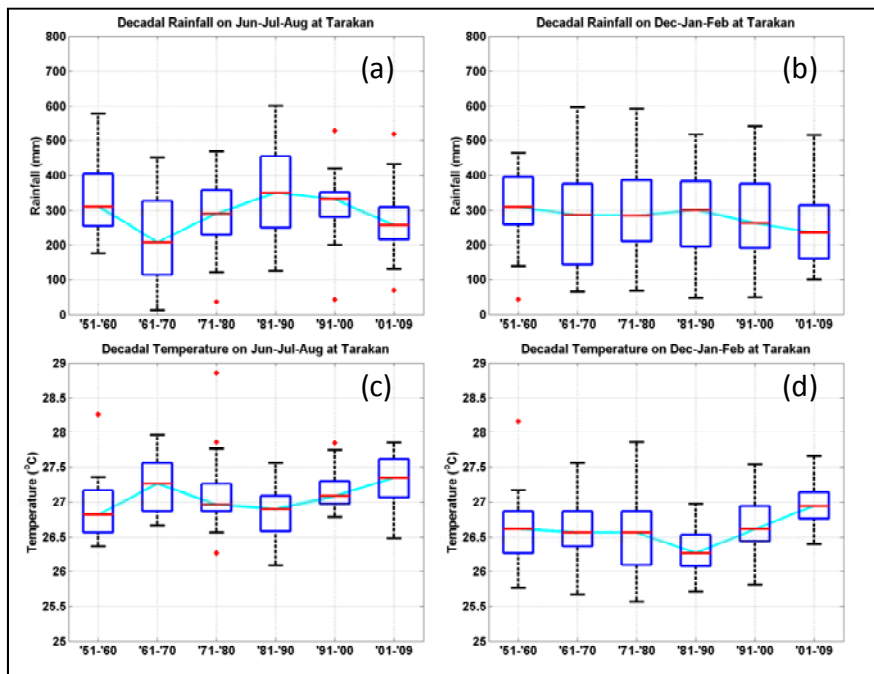

Figure 2.5 Box-plot diagrams showing statistics of monthly rainfall and temperature for June-July-August and December-January-February periods in every decade since year 1951. Upper and lower ends of the boxes designate lower and upper quartiles, while red lines indicate median values. In addition, dotted lines represent minima and maxima, whereas red dots indicate outliers.

### 2.1.3 Projection of Future Rainfall and Temperature Changes

Although there is a high degree of uncertainty, climate projection into several decades in the future is a fundamental element of climate change impact assessment. Two approaches may be used for climate projections: (i) projection based on an empirical regression model, and (ii) projection based on the output of Global Circulation Models (GCMs). In this study, the former is only applied for rainfall projection, while the latter is used for both rainfall and temperature projection.

### 2.1.3.1 Empirical Projection of Inter-decadal Rainfall Variations

As previously mentioned, inter-decadal rainfall variability may be associated with global oceanic variations known as PDO and NAO. Thus, an empirical regression between PDO and NAO indices and smoothed (or low-pass filtered) rainfall model can be developed to predict the trend of rainfall changes in the next couple of decades. Result of the empirical regression is presented in Figure 1.6. The regression parameters were chosen so as to obtain the best fit for testing the observation during the testing period, although there may be large differences between the model and observations during the training (development) period. The empirical projection is mainly for obtaining qualitative views of future trends in rainfall changes.

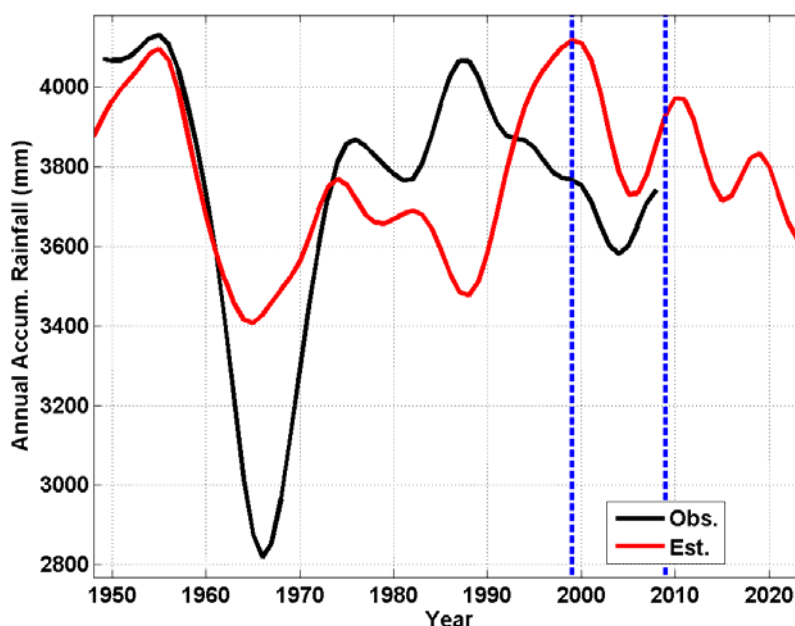

Figure 2.6 Result of empirical regression between PDO and NAO indices and smoothed annual rainfall observed over Tarakan (black line). Time window between blue dashed lines indicate “testing” period and red line shows projected rainfall 2010.

It can be seen from Figure 2.6 that there is a trend of decreasing rainfall from 2010 to 2020 with marked interannual variations. It should be noted that the correlation between rainfall and global climate indices may change phases so that the regression model fits well with observations during 1950s to 1960s but it shows large discrepancy for the 1970s to 1990s. However, the decreasing trend of rainfall is of primary interest and will be compared with the result of rainfall projection based on GCM outputs as described below.

### 2.1.3.2 Rainfall Projection Based on GCM Outputs

Global Circulation Models (GCMs) are the only tool that we can use to study the possible states of the Earth’s climate in the far future. Outputs of seven GCMs contributed for the IPCC AR-4 are used in this study to obtain projections of rainfall in Tarakan. Three carbon emission (SRES) scenarios i.e. B1 (low), A1B (moderate), and A2 (high) were chosen. The common problems with these GCM data for regional or local climate change risk assessment are the low horizontal grid

resolution and the diverse results of rainfall estimation, especially in the tropical regions. In this study, a simple ensemble averaging and bias correction method has been applied to the GCM outputs to produce the rainfall projections as shown in Figure 2.7.

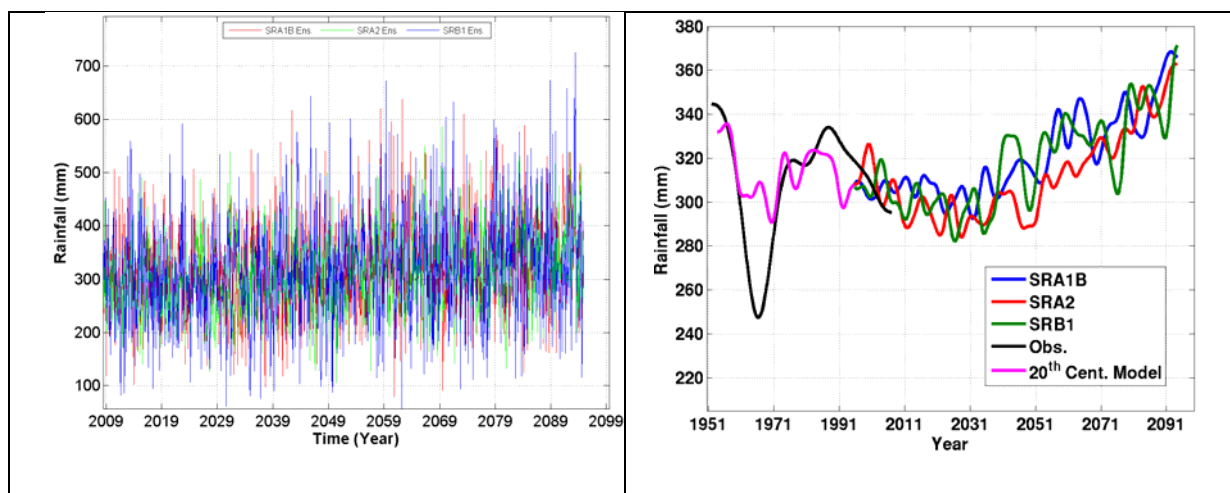

Figure 2.7 The GCM out based projected monthly rainfall of Tarakan for the 21<sup>st</sup> century (left) and the smoothed version with an extension back to 1951 (20<sup>th</sup> century) (right).

Although the models cannot perfectly match observations, Figure 1.7 shows that projected rainfall of Tarakan partially follows observed interdecadal variations. More importantly, there is also a decreasing trend from 2010 to 2030, which is consistent with the result of empirical regression as discussed previously (Figure 1.6). It should also be noted that, although the long-term trend is quite similar, there are also significant differences in the year to year variations between different scenarios.

### 2.1.3.3 Temperature Projection

Temperature projection has been made based on GCM output similar to that of rainfall as discussed previously. As it is shown in Figure 2.8, the models show uniform increase of temperature from 1990s to 2030 for all scenarios. After 2030 the trend splits between B1 (low emission) and other (A1B and A2) scenarios. This result, in general, conforms with the temperature global trend for the tropical region. Note that, although models seem to fit the trend of temperature increase, they cannot actually follow observed interdecadal variations. This is one of the weaknesses of the GCMs contributing to the IPCC AR-4. Developments of better GCMs are in progress and the results are planned for contribution to IPCC AR-5 but published materials are still limited.

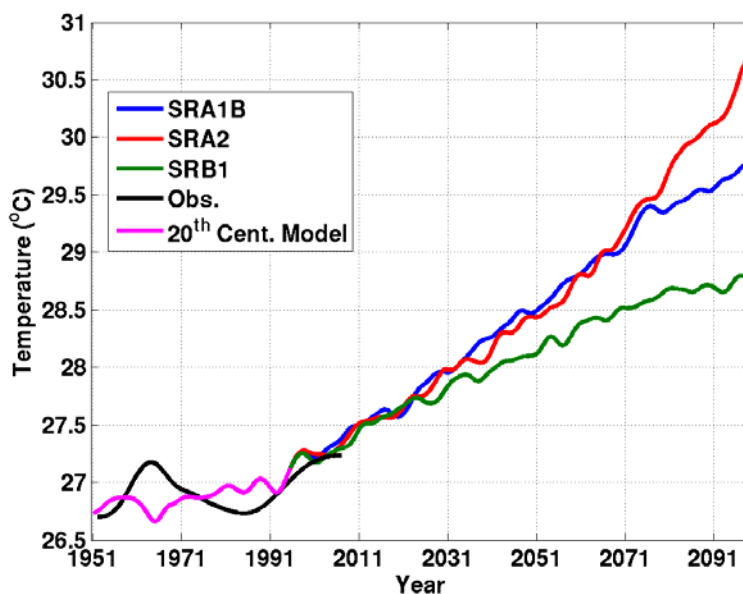

Figure 2.8 The GCM out based projected temperature of Tarakan for the 21<sup>st</sup> century with an extension back to 1951 (20<sup>th</sup> century). Data has been smoothed to show only the long-term trend.

#### 2.1.4 Analysis of Extreme Events

Information of extreme events is important in climate change risk assessments. Analysis and projection of extreme events are, however, more difficult to perform because it requires more detailed and accurate data. Long records of observed daily temperature and rainfall are at least needed to analyze the extreme events, while GCM outputs with daily time resolution are also required for the projection. In tropical region, extreme temperature events such as heat wave are very rare events. Therefore, only several aspects of extreme rainfall events at Tarakan are briefly discussed below.

##### 2.1.4.1 Historical Records of Extreme Rainfall

The best data for analysis of extreme events obtained in this study is probably daily rainfall data observed by BMKG station in Tarakan (Juwata). However, the record only spans from 2004 to 2009, which is not representative for climate analysis. Another data set shows maximum daily rainfall in each year from 1984 to 2001. Figure 2.9 shows the yearly maximum rainfall data of 1984 to 2001 combined with those derived from more recent data up to 2009. This is incomplete information of extreme events because the data samples cannot be used to construct probability of exceedance (PoE), which is a measure of the probability of an extreme event to occur in certain period of time.

From Figure 2.9, it can be seen that 100 mm/day seems to be the minimum threshold for extreme rainfall event and the most extreme rainfall occurred on 7 August 1998 with a record of 295 mm/day. Correlation between the probability of extreme monthly and daily rainfall has been investigated in this study using daily rainfall data of Singapore, which is considered to be the most representative data that can be obtained. Figure 2.10(a) shows a three curves fitted to some pairs of probability of monthly rainfall data with a certain threshold (400 mm/month for

Singapore) against that of daily rainfall (60, 80, and 100 mm/day). Data of Tarakan and Kenten (South Sumatra) are also plotted with adjusted threshold of monthly rainfall (433 mm/month in the case of Tarakan). It can be seen that data of all sites roughly follow the same trend. Hence, changes in the probability of monthly rainfall with certain thresholds are an indicator for the probability of extreme daily rainfall.

As it is shown in Figure 2.10(b), the projected probability of monthly rainfall above 433 mm differs with the B1, A1B, and A2 scenarios. Although the magnitudes are also different from observations, A2 scenario gives a quite similar trend to that of observations. It is inferred from these results that, until the 2030s, the probability of occurrence of extreme daily rainfall is likely to decrease or stay the same as present. However, it should be noted that after the 2050s the probability of extreme rainfall is projected to increase in all scenarios.

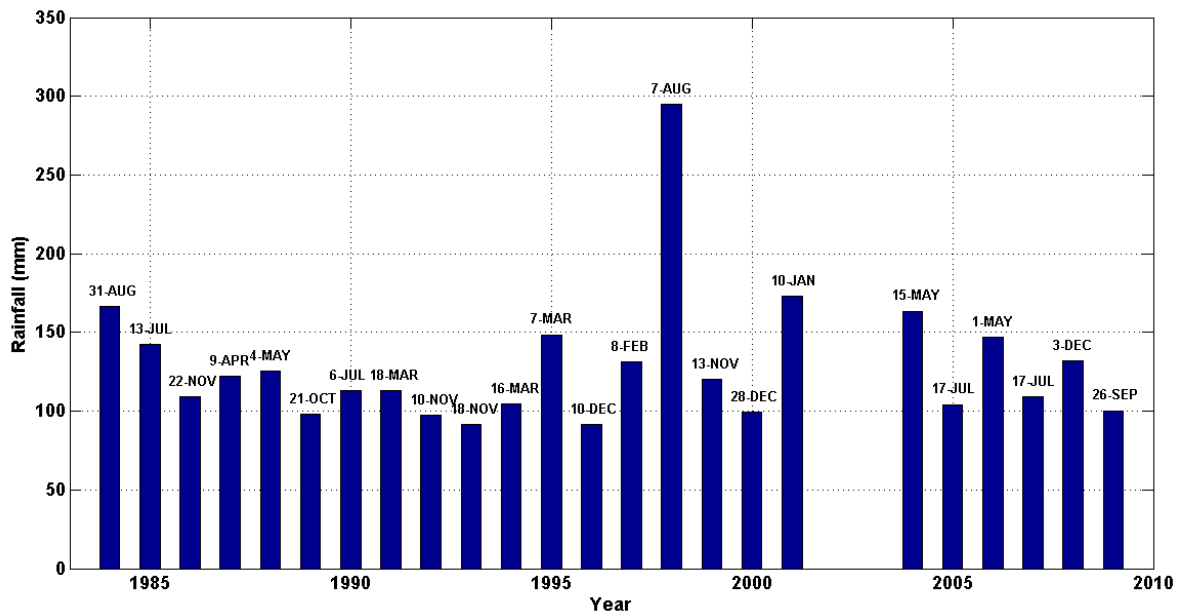

Figure 2.9 Records of maximum rainfall observed in Tarakan from 1984 to 2009.

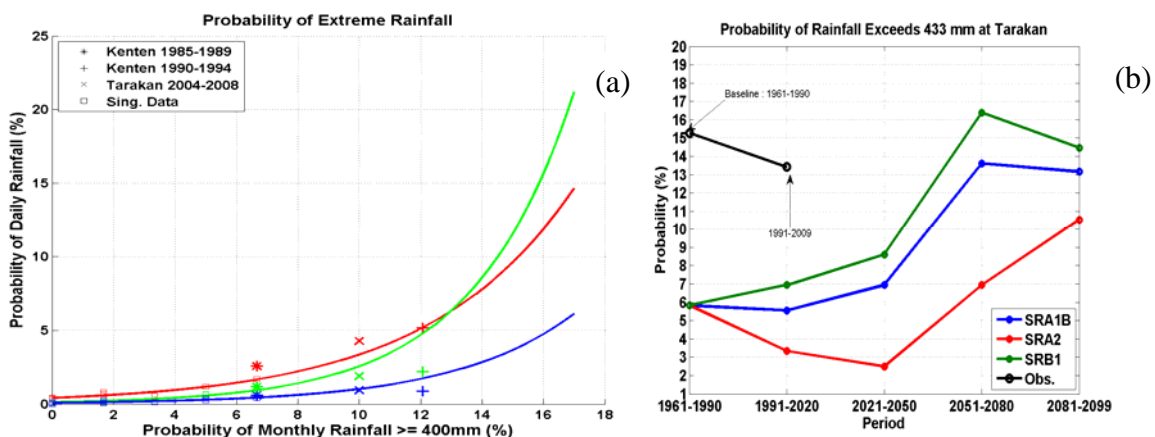

Figure 2. 10 (a) Correlation between the probability of monthly rainfall exceeding certain thresholds and the probability of daily rainfall exceeding 60 (blue), 80 (green) and 100 mm/day (red) with square symbol designating data of Singapore (threshold of monthly rainfall is 400 mm), while asterisk, cross, and plus symbols indicate data

of Knten (1985-1989), Knten (1990 – 1994) and Tarakan respectively (see text); (b) projected trend of the probability of extreme events (rainfall exceeding 433 mm).

## 2.2 Analysis and Projection of Sea Level Rise and Extreme Events

### 2.2.1 Background: Mean Annual Patterns of Sea Level, Surface Currents, Tidal Level, and Currents, and Wind Waves

#### 2.2.1.1 Sea Level, Surface Currents, and Indonesian Through-Flow (ITF)

The monthly mean sea level and surface currents at the south of the Sulawesi Sea near Tarakan during the peak of Asian and Australian Monsoon in January and August are presented in Figure 2.11a and 2.11b, respectively. Both sea level and surface current are based on the Hybrid Coordinate Ocean Model (HYCOM) model results. The sea level is high, and the southward ITF surface current is weak in January (Figure 2.11a). Due to stronger southward ITF surface current in August, the sea level is decreasing during this period as shown in Figure 2.11b.

However, the surface current near Tarakan is less affected by ITF, both during the Asian and Australian Monsoons. The surface current near Tarakan is weak (approximately 5 cm/s) and directed to the south and to the north during January and August, respectively. Based on these conditions, the surface current near Tarakan is highly affected by the tidal characteristics.

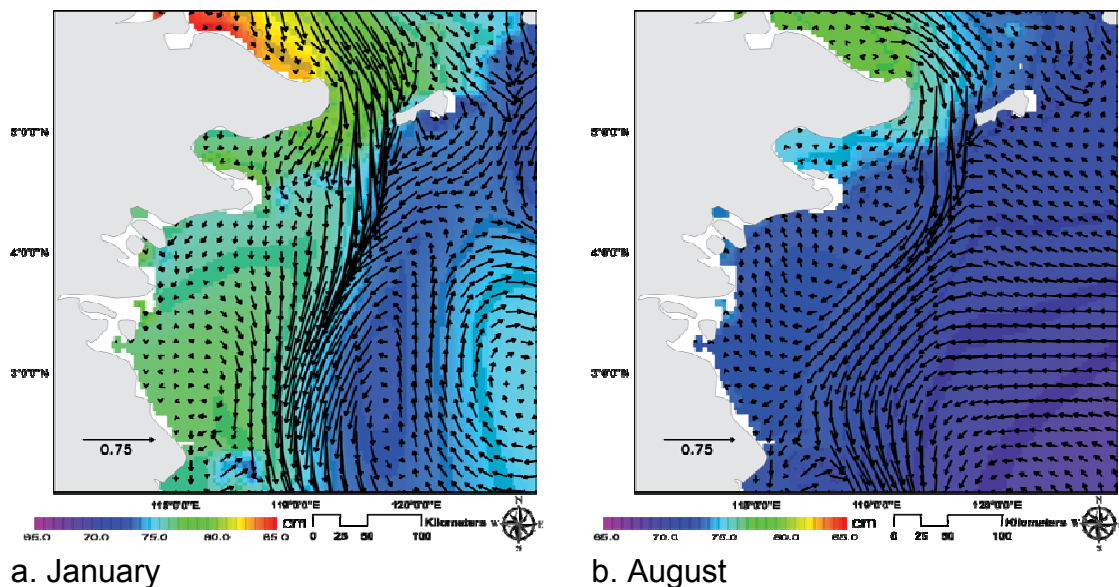

Figure 2.11 Monthly mean sea level and surface currents at the south of Sulawesi Sea near Tarakan during the peak of Asian and Australian Monsoon in January and August, respectively.

#### 2.2.1.2 Tidal Level and Currents

The tidal current along of Tarakan's coast during high and low tides are illustrated in Figure 2.12. The tidal level and currents are calculated using the Finite Volume Coastal and Ocean Model (FVCOM).

In general, the tidal current is directed to the east and away from Tarakan towards the open sea during high tide (Figure 2.12a). Conversely, the tidal current is directed towards Tarakan from the east, during the low tide (Figure 2.12b). Moreover, Figure 2.12a also shows that the tidal currents move to the south both at the eastern and western coast of Tarakan and out to the open sea with the speed of approximately 1 m/s. The tidal currents are directed to the north on both the eastern and western coasts of Tarakan and enter the river, during the low tide. The tide speed can up to 1.25 m/s during this period.

These tidal current characteristics both during the low and high tidal level indicate that the seawater circulation near the Tarakan just moves around the island and does not flow into the open sea. The pattern of these currents has an effect on pollutants transported from the rivers of Borneo and then move around the Island of Tarakan throughout the year.

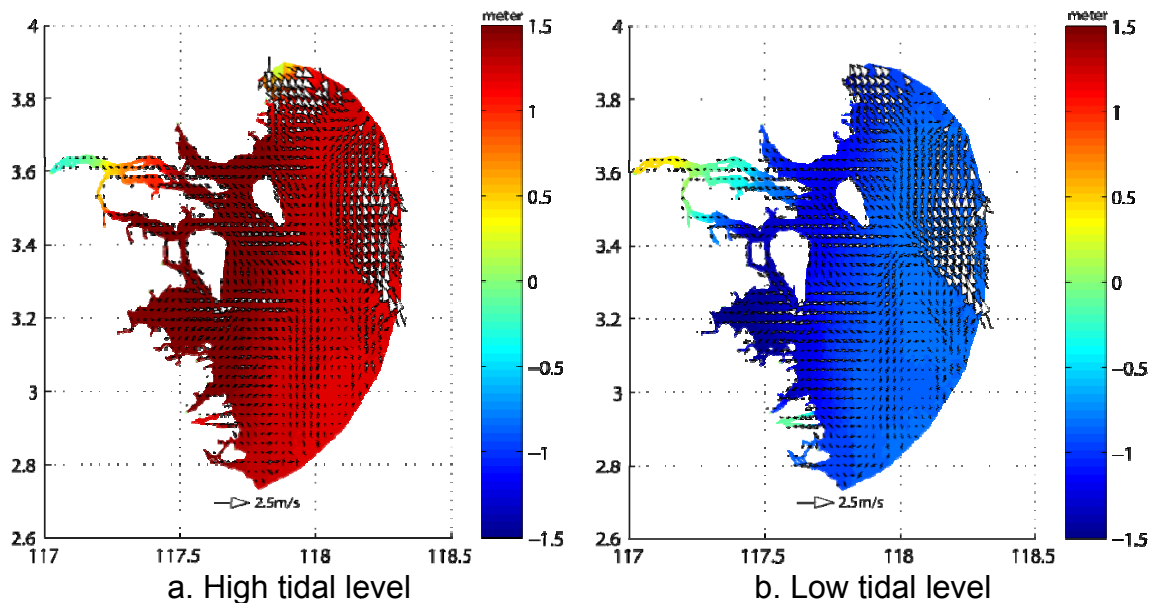

Figure 2. 12 Tidal level and surface currents during the high and low tidal level at coast of Tarakan and its surrounding shallow seas.

### 2.2.1.3 Sea Surface Temperature (SST)

The SST around Tarakan has been investigated by using the satellite-derived data (NOAA Optimum Interpolation Version 2 and NOAA Pathfinder) from 1982 to 2009. While the sea level rise rate is calculated based on the tide gauge at Sandakan, Tawau and Bitung from 1985 to 2007, and satellite altimetre from 1993 to 2009.

The annual SST at Tarakan has two peaks and two troughs. Heating from solar radiation and low wind speed in April during the monsoonal transition period causes the SST to reach its highest point in April, thereon decreasing to a low SST in August. Moreover, the lowest SST occurs in February when the ITF transport is low and the wind speed is high. The low ITF conveys less warm water from the Pacific Ocean and high wind speed causes the drop in SST during this period. Moreover, this low SST causes less evaporation of sea-water, and possibly influences the rainfall characteristics during this period.

## **2.2.2 Historical Analysis of Sea Surface Temperature and Sea Level Rise: Trend, Extremes**

### **2.2.2.1 Sea Surface Temperature**

The characteristics of Tarakan's SST are highly affected by La Niña. Predominantly, the SST anomaly is high during La Niña and drops to its lowest during the El Niño. However, during the strong El Niño 1997/1998, the SST remained high while the SOI dropped to its; this may be caused by the warm river flow that increases the SST near Tarakan. Thereafter, the SST started increasing and reached its highest during the La Niña 1999,. Furthermore, the time lag of about 2 to 3 months is clearly seen during the strong El Niño 1982, 1987, and 1997/1998.

On the other hand, the SST trend at Tarakan is only 0.004°C/yr. This low SST rise rate is possibly caused by the river flow from Borneo that brings water of a low temperature. However, the seawater in the eastern part of Tarakan still shows a high rate of increase about 0.02 °C/yr.

### **2.2.2.2 Sea Level**

On the other hand, the sea level is highly affected by the ENSO. The sea level is high during La Niña and drops to the lowest sea level during the El Niño phase. The sea level increases more than 10cm above the long-term mean, and 15cm decreases during the La Niña and El Niño phases, respectively. The Tarakan sea level response to the climate variability such as the ENSO is stronger than SST. The low Sea Level is linked with the regional scale of warm pool movement from the Indonesian Seas to the central Pacific Ocean, while the SST is more likely linked with the fresh water flows from the river that counterbalances the decreasing of SST during the El Niño.

Furthermore, based on the observational data, the sea level rise ranges from 4.5 mm/yr to 6.2 mm/yr, with the mean sea level rise is 5.4 mm. The sea level rise along the coast of Tarakan is higher than the global sea level rise which is only 3.3 mm/yr. However, the sea level rise at Tarakan is lower than the average of regional sea level rise throughout the Indonesian Seas that ranges from 6 mm/yr to 7 mm/yr.

### **2.2.2.3 Tidal Level and Range**

Both tide gauge and HYCOM-estimated tidal level show that the tidal range at Tawau near Tarakan is 3.5m. Therefore, it is recommended to use the high tidal range at Tawau as a basis for adaptation. Furthermore, the impact of El Niño on the tidal ranges are not clearly seen due to the decreasing of both maximum and minimum tidal levels, hence, the tidal range is not changing significantly.

However, the maximum annual tidal level is increasing about 25 cm and decreasing about 15 cm during the La Niña and El Niño, respectively. Moreover, it is sure that the increasing tidal ranges is linked with the rising of mean sea level during the La Niña, but it is hard to estimate the magnitude of tidal ranges rise due to the sea level rise as the impacts of global warming. Finally, the high tidal range in the peak of the



Asian Monsoon and La Niña periods will heighten the risk of flooding or inundation in coastal areas due to the high rainfall during these periods.

## 2.2.3 Projection of Sea Surface Temperature and Sea Level Rises

### 2.2.3.1 Projection of Sea Surface Temperature

The projection of SST based on the MRI (Meteorological Research Institute of Japan) by using the SRESA1b, A2, and B1 scenarios is depicted in Figure 3. The SST is projected to be rise 1.5°C to 2.5°C in 2100. While, the SST rise is 0.3°C to 0.5°C in 2030 relative to the one in 2000. Furthermore, the linear trend of SST rise is ranging from 0.15°C to 0.25°C per decade.

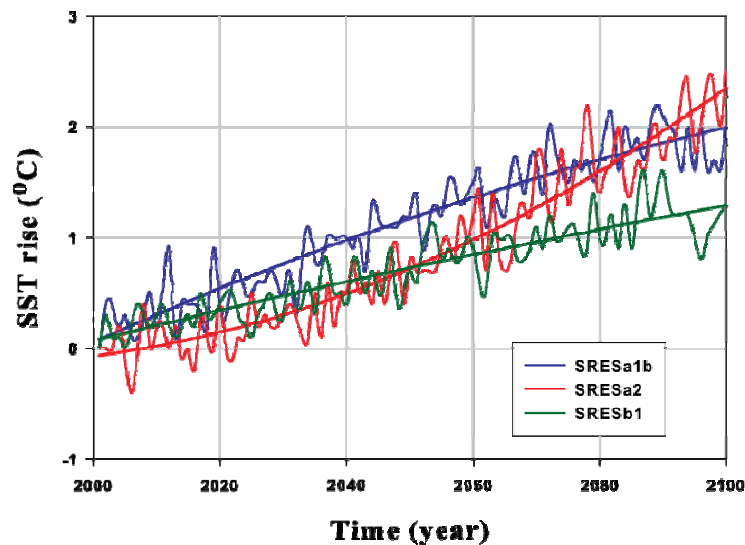
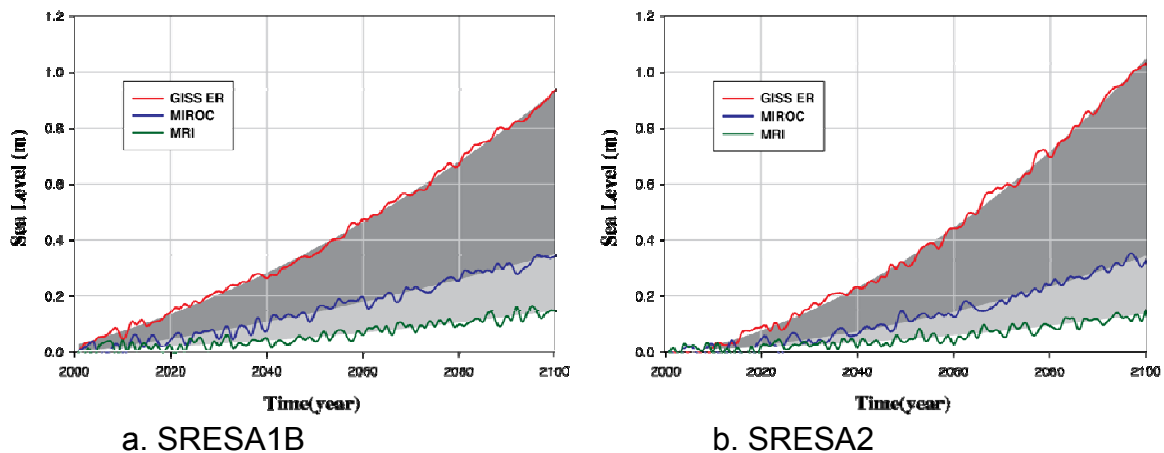
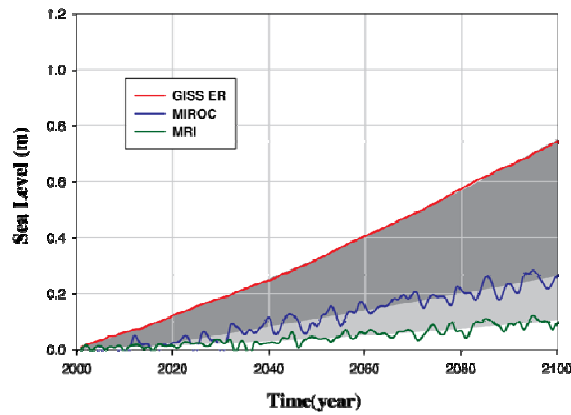

Figure 2.13 The SST projection based on the MRI model results for the SRESA1b, A2 and B1 scenarios





c. SRESB1

Figure 2.14 Sea Level Rise Projection based on Several Models and Emission Scenarios

### 2.2.3.2 Projection of Sea Level Rise

The projection of sea level rise based on the various models is depicted in Figure 4. Generally, the IPCC's models show a higher rise sea level than the one from observational data. The projection of sea level rise may vary from 2.5mm/yr to 1cm/yr depending on the emission scenarios that are used by the models. The sea level rise ranges from 10cm to 21cm in 2030, and finally reaches between 25cm and 105cm in 2100. Finally, the summary of sea level rise based on the observational data and the models is illustrated in Table 2.2.

Table 2.2 Sea Level Rise Projections based on the Observational Data and Models

	Observation		Model			Unit	Level of Confident
	Tide Gauge	Altimetre	SRESA1B	SRESA2	SRESB1		
2030	16.2	18.0	14.7 ±6.25	10.0 ±5.0	12.0 ±6.0	Cm	High
2050	27.0	30.0	26.0 ±11.0	22.0 ±11.0	22.5±10.5	cm	High
2080	43.0	48.0	48.0 ±22.0	48.5±23.5	39.0 ±18.0	cm	Very high
2100	54.0	60.0	65.5±28.5	70.0 ±35.0	50.5±22.5	cm	Very high

The contribution of ice-cap melting on the rise in sea level is also investigated by using altimeter and ECCO-derived model output. Both altimeter and model show similar characteristics and its rise rate from 1993 to 1998. This indicates that the sea level changes from 1993 to 1998 can be attributed to the steric sea level changes. The altimeter sea level rise increased from 1998 to 2010 and reached a rate of 6mm/yr, while the steric sea level rise was close to 0mm/yr. The contribution of the effects of ice melting to sea level rise in 2030 ranges from 14cm to 56cm, and 1.2m to 4.8 m in 2100. These contributions of ice melting (CIM) show that sea level rise cannot be precisely predicted by a physical model and other statistical methods, although the sea level probably will have risen by more than 2m in 2100. Furthermore, this result may also indicate that the CIM is becoming more dominant than the thermal expansion on the future sea level rise.

### 2.2.3.3 Projection of Extreme Events

The ENSO phenomenon is based on the changing patterns of ocean surface temperatures in the Pacific Ocean. Therefore, the frequency of El Niño and La Niña can be estimated using the data of NINO3 (the region of the eastern Pacific Ocean spanning from 210°E to 270°E and from 5°S to 5°N) SST.

Based on the analysis results, it is projected for ENSO events from 2001 to 2030 that strong El Niño occurrences will be less than 6.7%, following with moderate El Niño about 10%, and weak El Niño approximately 13% of the total 30 years time span. Therefore, the El Niño occurrences are nearly 30%. On the other hand, the total La Niña events are more than 55% consisting of 13% strong, 30% moderate, and 12% weak La Niña, while, the normal year is almost 10% to 15%, during that period. The recent La Niña-induced sea level rise along the coast of Tarakan is 15cm.

However, it is predicted that the La Niña effect on the sea level characteristics will be getting higher than 15cm in the near future, due to the rising sea level from global warming. Furthermore, longer and more frequent La Niña events may lead to the strengthening of local winds through the impact of high sea surface temperature. Therefore, extremely high wave occurrences will produce higher waves in the future compared to present conditions. More frequent and longer La Niña will leading to strengthening of wind speed, increasing of wave height and rising sea level. This extreme weather will lead to increased flood risk, affecting marine transportation, and worsening coastal erosion in the future.

Table 2.3 ENSO Time Table based on MRI Model Output for SRESA1B Scenario

	Jan	Feb	Mar	Apr	Mei	Jun	Jul	Agus	Sep	Okt	Nov	Des
2001	-1.04	-0.86	-0.81	-0.33	-0.55	-0.29	0.12	0.26	-0.34	-0.85	-0.85	-1.02
2002	-1.04	-0.77	-0.47	0.13	0.77	0.75	1.00	1.37	1.47	1.77	1.79	1.60
2003	1.13	0.81	0.09	-0.35	-0.56	-0.61	-1.16	-1.16	-1.05	-0.67	-0.69	-0.95
2004	-0.83	-1.20	-1.19	-0.86	-0.37	-0.78	0.30	0.42	0.77	0.93	0.89	1.13
2005	0.84	0.29	0.00	-0.25	-0.38	-0.75	-0.45	-0.68	-0.32	-0.77	-1.07	-0.99
2006	-0.89	-1.12	-1.19	-1.79	-1.68	-1.04	-0.53	-0.41	-0.36	-0.30	-0.28	-0.55
2007	-0.63	-0.93	-0.80	-0.72	-0.91	-0.29	0.10	0.23	0.43	0.72	0.76	0.69
2008	0.78	0.53	0.23	0.06	-0.90	-0.76	-0.84	-0.36	-0.67	-0.82	-0.75	-1.01
2009	-1.07	-0.78	-0.11	0.07	0.29	1.21	1.39	1.58	1.36	1.29	1.38	1.31
2010	0.98	0.56	-0.26	-1.18	-1.48	-1.23	-1.44	-1.74	-1.56	-1.86	-1.93	-2.11
2011	-1.98	-1.91	-1.63	-1.28	-0.10	1.53	2.21	1.99	2.24	2.40	2.73	3.06
2012	2.75	2.37	1.61	1.00	0.83	-0.06	-0.20	-0.01	-0.78	-1.02	-1.18	-1.59
2013	-1.45	-1.22	-0.54	-0.50	-3.42	-0.11	0.04	0.50	0.38	0.07	-0.08	0.12
2014	0.03	-0.20	-0.27	0.31	0.04	-0.24	-0.35	-0.46	-0.44	-0.14	-0.59	-0.54
2015	-0.70	-0.91	-0.50	-0.13	-0.04	-0.44	-0.15	-0.39	-0.05	-0.26	-0.52	-0.55
2016	-1.09	-0.91	-0.36	0.02	0.11	0.12	0.67	-0.03	-0.43	-0.45	-0.84	-0.97
2017	-1.09	-1.18	-1.30	-0.68	-0.95	-1.33	-1.09	-1.67	-1.91	-2.00	-2.09	-2.20
2018	-1.93	-1.97	-1.80	-1.36	-0.52	1.09	2.24	1.65	1.74	1.94	2.23	2.36
2019	2.50	2.25	1.85	1.39	1.19	0.73	0.50	0.73	0.45	0.17	-0.42	-0.78
2020	-0.82	-1.03	-0.85	-0.74	-1.26	-1.13	-1.41	-1.71	-2.28	-2.16	-2.35	-1.87
2021	-1.51	-1.54	-1.50	-1.09	-3.15	0.14	0.06	0.24	-0.21	-0.27	-0.08	-0.02
2022	-0.06	-0.18	-0.53	-0.56	-0.50	-0.83	-0.48	-0.40	-0.60	-0.71	-0.95	-1.49
2023	-1.40	-1.32	-0.90	-0.46	-0.03	1.05	0.63	1.13	1.04	0.92	0.73	0.25
2024	0.47	0.36	-0.28	-0.94	-1.33	-1.25	-1.31	-0.95	-0.85	-1.03	-0.90	-0.88
2025	-0.86	-0.97	-0.47	-0.66	-0.65	-0.48	-0.53	-0.36	0.29	0.53	0.70	0.50
2026	0.73	0.71	0.42	0.23	-0.56	-0.83	-0.85	-1.23	-1.87	-1.59	-1.64	-1.43
2027	-1.38	-2.00	-1.94	-1.49	-0.48	0.11	0.12	0.40	0.44	0.38	0.06	-0.38
2028	-0.54	-0.26	0.03	-0.20	-0.81	-0.64	-0.27	-0.44	-0.04	0.28	0.02	0.08
2029	0.26	0.39	0.18	-0.34	-0.65	-0.88	-1.37	-1.47	-1.94	-2.25	-1.92	-1.24
2030	-0.92	-0.80	-1.14	-0.89	-0.77	-0.79	-0.19	-0.12	0.51	0.45	0.56	0.37

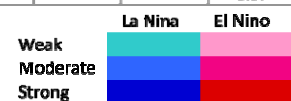

## **2.2.4 Wave Height Characteristics**

### **2.2.4.1 Mean Annual Patterns**

Analysis of time series of significant wave height (SWH) is based on Wavewatch III model results from 2000 to 2008 using the blended QuickScat and NCEP wind data (an illustration is presented in Figure 2.15).

In general, the SWH at the east coast of Tarakan is high during the Asian Monsoon and drops to the lowest in the Australian Monsoon period. This is caused by the weakening of Rossby wave propagation from the Pacific Ocean via the Sulawesi Sea to the east coast of the island of Tarakan. The wave height is high in November to January during the peak of the Asian Monsoon and then decreases to its lowest in May. The SWH is low during the Australian Monsoon, although high waves still occur in August and September. The highest SWH on the east coast of Tarakan is only 1m to 2m but coincides with high tide during January. As a result, superposition between wave and high tide can heighten the risk of inundation, and increase abrasion and erosion.

### **2.2.4.2 Extremes**

However, extreme wave height was seen on September 16th, 2000 in the Australian Monsoon during La Niña phase. This high wave was caused by strong local wind speeds near Tarakan that reached 20 m/s. The strong local wind generated high waves only in a limited area where the extreme waves reached 3.8 m. This extreme local climate phenomenon is very likely linked to climate change and climate variability such as La Niña that not only affect the regional climate system but also the local one.

In the La Niña phase, generally, the trade winds from the Pacific Ocean strengthen, which should enhance the wave height. Meanwhile, the influence of climate variability such as La Niña is not clearly seen on the annual mean SWH. The lower SWH than expected during La Niña may be due to wave propagation attenuation from the Pacific Ocean to the Celebes Sea by the geographic location of the Philippine archipelago and its bathymetric features. The propagation of Rossby wave decreases within the Celebes Sea, and low wave height packet reaches the east coast of Tarakan.

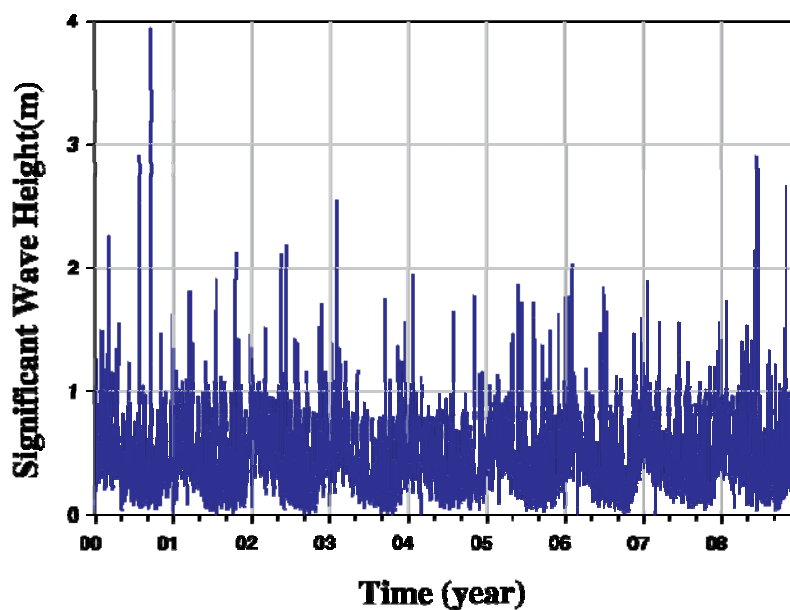

Figure 2.15 Time-series of significant wave height (SWH) based on Wavewatch III model results from 2000 to 2008 using the blended QuickScat and NCEP wind data.

### 3. Methodology of Risk and Adaptation Assessment

This part will provide information on the approach, framework, and methods being used to assess climate hazard, vulnerability, and risk in Tarakan City. In addition, assumptions for the future trends (related to climatic and non-climatic hazard) and the limitations will also be explained here, since it affects the method for assessing hazard and vulnerability.

#### 3.1 Approach, Conceptual Framework, Steps, and Time Frame

Recent studies on Climate Change Impact, Adaptation, and Vulnerability (CCIAV) suggest that there are at least five types of assessment approach<sup>1</sup>; i.e. a conventional approach consists of impact assessment, adaptation assessment, vulnerability assessment, and integrated assessment<sup>2</sup>. As for the fifth approach, it can be inferred as emerging approach in CCIAV, as it adopts a risk assessment framework. The fifth approach has begun to mainstream climate change adaptation into the enactment of development policy (IPCC, 2007). In addition, there has also been some shifting from research driven into a more integrated work towards policy-making, in which the decision maker and the entire set of stakeholders participated in the assessment and sometimes act as the initiator (UNDP, 2005).

In the context of mainstreaming climate change into development policy in Indonesia, it is recommended to differentiate climate risk and adaptation assessment into macro, meso and micro levels thereby aligning it to the hierarchical structure of government:

<sup>1</sup> Assessment approach can be defined as direction and scope of study in which particular assessment being conducted. An approach may consist of several different methods. In addition, method itself is being defined as a systematic analytical process.

<sup>2</sup> See "Decentralized Vulnerability Assessment to Climate Change Assessment in Indonesia: Using Regional-Multi Sector Approach at Provincial Level", in Suroso (2008).

national, province and local (see Table 3.1). Each level of assessment represents the detail of analysis taken; hence it indicates the level of accuracy of the results which corresponds to the adaptation needs for each level of government's structure. The method of this study is a micro-level approach with the city as the administrative location of the study. Therefore, it is more detailed than those used in previous works, such as in Indonesia Climate Change Sectoral Roadmap (macro-level study) and Climate Risk and Adaptation Assessment on Lombok– West Nusa Tenggara Province (meso-level study). As a micro level study, the impact of climate change will be analysed in the sense of how it would affect selected sectors within the lowest administrative division in Tarakan City; i.e. *kelurahan* – comparable with village (the term “village” will be used throughout the study).

Table 3.1 Various Levels of Risk and Adaptation to Climate Change

<b>Scale</b>	<b>Data and Analysis</b>	<b>Scope</b>	<b>Level of Planning</b>	<b>Accuracy</b>	<b>Finance</b>
<i>Macro</i>	<i>Qualitative</i>	<i>National</i>	<i>Adaptation Policy</i>	<i>Low</i>	<i>Low</i>
<i>Meso</i>	<i>Combination of qualitative and quantitative</i>	<i>Provincial</i>	<i>Adaptation Strategy</i>	<i>Medium</i>	<i>Medium</i>
<i>Micro</i>	<i>Quantitative</i>	<i>Local</i>	<i>Adaptation Actions</i>	<i>High</i>	<i>High</i>

Source: modified from Messner (2005) in Suroso (2008)

A risk assessment framework has been well developed within natural disaster communities and has started to be adopted for the study of climate change (Klein, 2004). Since the Third Assessment Report, the definition of vulnerability from the IPCC has been improved to take into account social vulnerability (O'Brien, et al., 2004) and to reconcile it with risk assessment (Downing and Patwardhan, 2005). The framework and methods for vulnerability assessment must also include adaptive capacity indicators (*Turner, et al., 2003; Schroter, 2005; O'brien and Vogel, 2006*).

Affeltranger, et al. (2006) proposed a risk notation (Risk), as a function of Hazards and Vulnerability using the formula<sup>3</sup>:

$$\text{Risk (R)} = \text{Hazards (H)} \times \text{Vulnerability (V)}$$

IPCC (2001) defines vulnerability as follows: “a function of character, magnitude and rate of Climate Change and the variation to which a system is exposed, its sensitivity and its adaptive capacity”. In the context of risk and adaptation assessment to climate change, based on the risk notation from Affeltranger, et al. and vulnerability definition from the IPCC above, we can determine two definitions as follows:

- 1) Hazard due to climate change is a function of characteristic, magnitude, and rate of climate change and variability.
- 2) Vulnerability of a system to climate change is a function of exposure, sensitivity, and adaptive capacity.

<sup>3</sup> See further on *Decentralised Vulnerability Assessment to Climate Change Assessment in Indonesia: Using Regional-Multi Sectoral Approach at Provincial Level* by Suroso (2008).

As follows, here are the general steps of climate risk and adaptation assessment being done in Tarakan City:

**1) Formulation of Problems and Identification of Vulnerable Sectors to Climate Change**

This step is very important in laying the foundation for the study. Techniques which can be implemented include brainstorming, public consultations, and focus group discussions. This step is aimed to determine sectors which are considered to be vulnerable to climate change and also as a forum for early interaction with stakeholders in concerned regions. In this step, we can also communicate on data needs and availability between the experts involved in this study and related institutions in the region.

**2) Analysis of Hazard due to Climate Change**

In this step, the character, magnitude, and rate of hazards are analyzed based on current and historical climate information, and also future projections of climate change.

**3) Analysis of Vulnerability of Sectors due to Climate Change Impact**

In this step, identification of vulnerability indicators, data collection, and analysis of GIS (Geographic Information System) are conducted. Then, vulnerability maps can be produced.

**4) Analysis and Evaluation of Climate Risk for Sectors**

As defined by Affeltranger, et al. (2006), risk is a result of overlay between hazard and vulnerability. Thus, risk levels are obtained from overlay between maps resulted by Step 2 and Step 3 above.

**5) Formulation of Adaptation Strategies for Sector**

Having completed Step 1 to Step 4, a good understanding on the level of risk of vulnerable sectors will be obtained so that appropriate adaptation strategies/measures can be identified to respond to climate change impact .

**6) Multi-Risk Assessment and Adaptation Prioritisation**

After the risk assessment being completed by each sector has been followed by initial adaptation recommendation, the multi-risk assessment and adaptation prioritisation are started. In a multi-risk assessment, the study overlays all the general risk profiles of sectors in Tarakan, as well as its regional adaptation concept. Therefore, particular tsubdistricts or villages exposed to more than one hazard can be identified. In addition, the adaptation prioritisation is conducted through an iterative process of short-listing the tsubdistricts and villages based on the various aspects of their vulnerability.

**7) Mainstreaming Adaptation Strategies into Development Policies**

Climate risk assessment and policy making do not occur in a vacuum, particularly within the provincial government context. Climate change is only another factor to consider among the many aspects that provincial government already takes into account in all its policy-making. Climate change considerations may revise policies through the application of risk management processes in prioritizing adaptation options.

The emphasis here is on understanding the scope and variation of climate change, and applying risk assessment as a method to determine adaptation responses based on the risks. 'Best' knowledge of climate change, together with use of risk assessment procedures, can help local government prepare to help the community adapt to known climate change.

Risk management is well fitted into plan making and review processes at the stages where issues are being identified and a range of possible response options evaluated. The iterative process of plan formulation, monitoring and evaluation enables for revision of plans over time to take account of improved understanding of risks due to climate change. In considering climate change issues, the period over which the decision will have effect is of fundamental importance. Generally, whenever a decision is likely to have effects that will last 30 years or more, the implications of climate change should be taken into account.

In general, the climate risk assessment for Tarakan City will be conducted for both the baseline situation and future projection. For baseline analysis, year 2010 is being used as reference, thus almost all of the single year data were dated 2010 and historical data ended in 2010. The climatic projection being done as the supporting scientific data for this assessment is until 2100; in addition it was divided into 30 year periods. As for the risk projection, year 2030 was chosen as the projected year situation. Therefore, hazard, vulnerability, and risk projection are dated this year as the end of projection; in addition several analyses divide each 5 year period as their stages. The selection of year 2030 as the end year was also due to the time frame of the development system in Tarakan City; i.e. compatible with the General Spatial Plan of Tarakan City (RTRW) that planned until 2030. As the Long-Term Development Plan of Tarakan City (RPJP) was actually dated to be legal until 2025, however, it will still be compatible since the RTRW used it as a reference, and also the staging for each 5 years helps to make them compatible with each other.

### **3.2 Methodology for Hazard Analysis**

Analysis of each hazard type is conducted using different methods or models, with different inputs or parameters. Most parameters used in the analysis are taken from the results of the supporting scientific data study as summarized in the previous chapter. The hazard analysis is performed for current conditions, as baseline, and for the future, which has taken into account the climate projection in the method or model. There are several projection scenarios used in this study, according to IPCC, i.e. SRES B1, A1B and A2. For the further hazard analysis only SRES A1B was used as the moderate scenario among others. The list of methods or models and the parameters used in hazard analysis for each hazard type is provided in the table below.

Table 3.2 Method/Model and Parameters in Hazard Analysis

<b>Hazard Type</b>	<b>Method/Model</b>	<b>Main Parameters</b>
<b>Coastal: Inundation</b>	Cumulative Inundation model and scenario	Tide Wind wave Storm surge La Niña Global SLR



<b>Water: Flood</b>	HECRAS	Rainfall Coastal inundation Soil type Land use change
<b>Water: Landslide</b>	GEOSLOPE	Rainfall Soil type Land use change
<b>Water: Shortage</b>	Water balance	Rainfall Temperature Soil type Land use change
	Water budget	Total Run-Off Population Land use
	FEM WATER	Aquifer geometry Permeability Groundwater storage
<b>Health: Dengue, Malaria, Diarrhea</b>	Regression and correlation model	Rainfall Temperature Incidence rate

### 3.2.1 Coastal Sector Hazards Model and Scenario

#### 3.2.1.1 Introduction and Definition of Hazards

Coastal hazards induced by climate change tend to occur in the same area and exacerbate each other, thus increasing the risk of repetitive loss from all hazards. For individual communities, occurrences of rare large-scale hazards such as storm surges, tidal surges (“rob”), ENSO (especially La Niña) and tsunamis are low (annually to decadal). On the other hand, medium and localized small-scale hazards such as floods due to rainfall, tide and wind waves might occur more frequently (daily, monthly to yearly). While coastal flooding or inundation due to sea-level rise is another type of hazard that has slow onset characteristics so that it would become a real threat in the future but to be anticipated from today. It is noted that all these hazards could potentially occur in Tarakan’s coastal areas, so they become elements of hazard to be assessed, except rainfall-triggered flood that will be considered in the water sector. In a cumulative manner, all these or some events may result in significant losses.

Threats of hazards vary within geomorphologic features, such as: coastal areas and low laying areas and not all hazards constitute important threats to each community depending on their location, and characteristic and behavior of the hazards. It is therefore necessary to define hazards for further analysis and characterization.

The probability of specific hazards occurring in individual communities will differ depending on such variables as climate, geology, bathymetry/topography, coastal geometry and land-use patterns. For some hazards, the entire community will have similar susceptibility, such as from a cyclone and tsunami. For others, such as flooding/coastal flooding (from the rain fall and from the sea), some portions of the

community may be impacted more than others; for example, low-lying areas are more susceptible to inundation. For this reason it is important to obtain maps for as many types of hazards as possible and to clearly delineate the specific characteristics and small-scale location based variables that will become important considerations when developing an adaptation strategy.

### 3.2.1.2 Hazards Model for Mapping

A hazard map is developed by a simple analytical model representing occurrence of cumulative hazards of flooding or inundation that could occur in coastal areas according to a scenario of a set of conditions. Mathematically, the model is presented as follows:

$$H = \sum_{i=1}^N h(i)$$

where: H is total coastal inundation hazard level above mean sea-level, h(i) is *i*-th level of each type of hazard (SLR, ENSO, surges, wind waves, tides, tsunami), and N is number of hazard type being assessed for each condition scenario. An illustration of this cumulative hazard model is depicted in Figure 3.1.

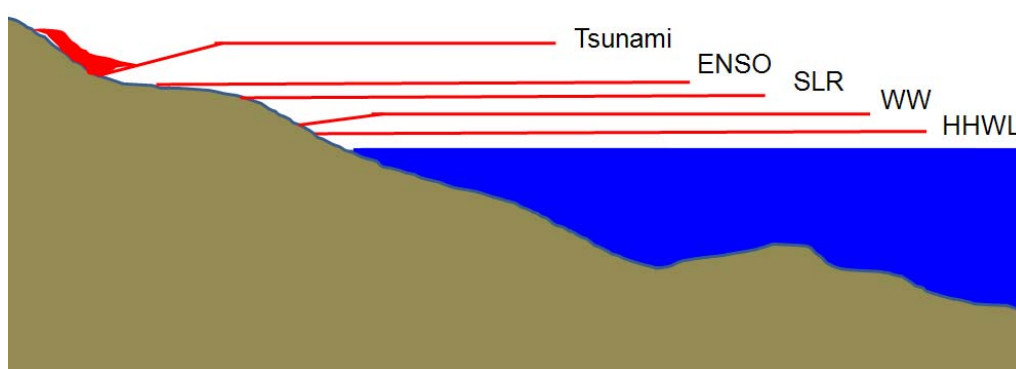

Figure 3.1 Elements of hazards induced by sea level change

In some cases the evidence of hazards may not be available in the map; therefore, it will be necessary to rely on qualitative information such as verbal histories through public hearing and field survey. For each hazard, variables could include Inundation boundaries; location of abrasion, sediment transport and others.

In this assessment, the following six hazards scenarios are proposed, where each scenario is a combination of hazard elements associated with the projected global sea level rise of **14.7 ± 6.25 cm** in 2030.

#### 1. Scenario-1a (significant conditions scenario):

It is the scenario of when a hazard combination of wind waves with significant height (SWH) and global sea level rise (SLR) occur in the time of mean highest water level (MHWL) due to tidal fluctuation.

Typically, Tarakan coastal areas have MHWL of 120 cm and wave setup due to SWH of 38.4 cm, hence, in this significant scenario, baseline and projected hazard

levels are about 158.4 cm and 173.1 cm above recent mean sea-level (MSL), respectively.

**2. Scenario-1b (extreme conditions scenario):**

This scenario is an extreme version of scenario-1a above: When maximum height of wind wave and SLR occur in the time of highest high water level (HHWL). Therefore, in this extreme scenario, baseline and projected hazard levels are 210.1 cm and 224.8 cm above recent MSL, respectively.

**3. Scenario-2a (scenario of extreme and La Niña conditions)**

This scenario represents conditions of the above scenario that is further combined by La Niña hazard so that the sea level rise is 15 cm higher and accordingly coastal inundation is wider than in the preceding scenarios both in baseline and projected conditions.

**4. Scenario-2b (scenario of extreme and surge conditions):**

This scenario is similar to scenario-2a above but La Niña event is replaced with cyclonic and storm surge conditions with a typical increase of sea-level of about 30 cm.

**5. Scenario-3 (scenario of extreme and La Niña and surge conditions):**

This scenario represents the conditions when a combination of overall climate-related hazards occurs in the same time. Baseline and projected hazard levels are about 255.1 and 269.8 cm above recent MSL, respectively. This condition will mainly be considered in the assessment of risk induced by climate change.

**6. Scenario-4 (scenario of extreme and tsunami condition):**

This scenario represents the conditions when tsunami could occur in the extreme conditions scenario. It is interesting to assess the impact of sea level rise in the same time of tsunami occurrence, which has the highest level of 524.8 cm.

A summary of the overall sea level hazard scenarios can be seen in the following Table 3.3 for SRES A1B.

Table 3.3 Scenarios of Cumulative Hazards for SRESA1B Scenario

Elements of Hazard	Hazard code	Projection SRES-A1B		Frequencies
		2010 (cm)	2030 (cm)	
Tide(MHWL)	1a	120	120	520 hours/year (5.93%)
Tide(HHWL)	1b	160	160	46 hours/year (0.52%)
Wind Wave	2a	120	120	18.3days/year (5.01%)
	set-up	38.4	38.4	T=8 sec
	shoreward displacement	7675	7675	
	2b	160	160	9days/year (2.36%)
	set-up	50.1	50.1	T=7 sec
	shoreward displacement	10200	10200	
Sea Level Rise (A1B)	3	0	14.7 ± 6.25	projected
La Nina	4	15	15	1 event/ 2-3 year
Storm Surges and Tidal Surges	5	30	30	3 event/ year (3 days duration)
Tsunami	6	300	300	1 event/100 year
<b>Scenarios</b>	<b>Cummulative</b>			
Scenario-1a(Significant)	1a+2a+ (3)	158.4	173.1	2.97E-01
Scenario-1b (Extreme)	1b+2b + (3)	210.1	224.8	1.23E-02
Scenario-2a (Extreme+ La Nina)	1b+2b+4 + (3)	225.1	239.8	6.14E-05
Scenario-2b (Extreme + Surges)	1b+2b+5 + (3)	240.1	254.8	1.23E-04
Scenario-3(Extreme + La Nina+ Surges)	1b+2b+4+5 + (3)	255.1	269.8	6.14E-07
Scenario 4 (Extreme + Tsunami)	1b+2b+6 + (3)	510.1	524.8	1.23E-06

### 3.2.2 Water Sector Hazards Model and Scenario

In detail, water shortage hazard in baseline conditions is being defined as decreasing of water availability (DoWA) plus value of water demand (WD), thus being divided by the total water availability. The DoWA and total water availability for baseline condition are calculated using water balance analysis method. The result of water balance analysis is expressed in terms of total runoff (TRO), direct runoff (DRO), and groundwater storage (GW). In addition Cumulative Distribution Function (CDF) analysis as illustrated in figure 3.5 is used to calculate the total runoff (TRO) resulting from water balance analysis. Therefore, DoWA also can be inferred as probability of the decreasing of water compared to the normal condition. In this sense 50% TRO based on conditions from 1960 – 1990 was being defined as a reference, thus a value below 50% TRO will be concluded as water availability shortage. On the other hand, water demand is the aspect that may elevate the water shortage hazard. In this study, water demand for baseline situation has been calculated spatially based on domestic and industrial use; as for projection, the calculation was based on population projection and type of land use based on The RTRW of Tarakan City.

Flood hazard modeling was being conducted through the land use, rainfall, discharge, and a digital elevation map (DEM), as well as sea level rise for the projection context. Both baseline and projection of flood hazard analysis was conducted through the Watershed Modeling System (WMS). As the first step on WMS, land use, plays a vital role in determining the roughness of land surface, thus it may affect the overland flow, discharge, and runoff behavior in a particular watershed. Each land use type in Tarakan City, baseline and future based on the RTRW of Tarakan City, is then assigned a specific roughness value. The second step in WMS is to delineate the watershed, banks, and determination of centre line of stream. Afterwards the flood analysis is transferred to the HECRAS model to analyse the discharge and water level data.

The landslide hazard model is developed by utilising the concept of extreme rainfall and unique relationships between rainfall characteristics, hydraulic conductivity, suction, and water content of unsaturated soil to evaluate the minimum suction distribution and factor of safety of soil slope. The development of landslide modeling being done is due to the decreasing value of cohesion from existing values to the last possible values. Hence the decreasing value indicates that extreme rainfall that infiltrated the ground changes the unsaturated soil to the saturated one. In this analysis, rainfall is a key factor in determining groundwater recharge and changes in the amount frequency, duration, and intensity. Rainfall will have significant impact on groundwater resources in which its response to rainfall has a longer lag time than the correspondence between hydrological response in surface water systems. The ground water table recharge estimated using the CRD method based on existing rainfall data between the years 2001-2010, as for the projection it was calculated for years 2011-2030. The projection itself was being divided into two parts, 2011-2020 and 2021-2030. The CRD method needs infiltration and pumping data, there are 11 different locations to estimate changing of groundwater elevation.

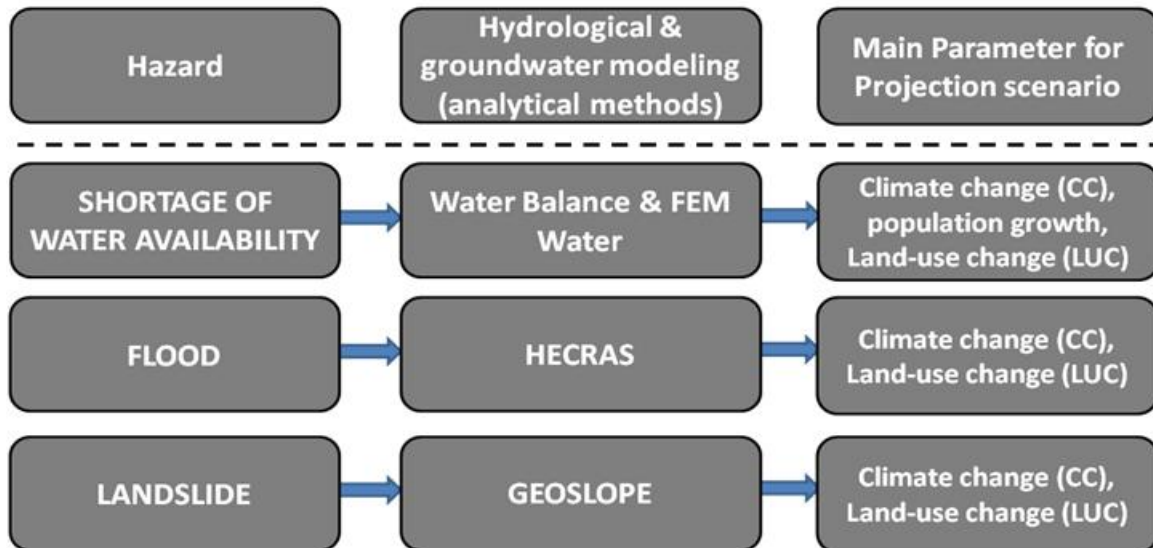

Figure 3. 2 Hazard Projection Modelling Process of Water Sector

### 3.2.3 Health Sector Hazards Model and Scenario

Assessment of causal relationship between prevalence of DHF, malaria, and diarrhea with temperature and rainfall as climatic factors was conducted as part of the hazard analysis in this study. Some exercises to discover the correlation between DHF cases and rainfall and between DHF cases and temperature in Tarakan were conducted using Pearson correlation and Spearman correlation. Then, hazard models were conducted by two different methods, the Poisson regression method and the Compartment model method.

#### (1) Poisson regression method

DHF incidence data is not a normal curve, therefore Poisson regression is used in the mathematical modeling and prediction. Several studies had succeeded in utilising multiple regression analysis in finding statistical association between climate variability and diseases incidence. The following equation is the general equation applied in this study, using Poisson regression with Auto-regressive term:

$$\ln(Y_t) = \beta_0 + \beta_1 \ln(Y_{t-1}) + \beta_2 T_t + \beta_3 R_t + \beta_4 P_t + \hat{P}_t \epsilon$$

Let:

$Y_t$  as the number of dengue cases in month t;

$T_t$  as the average temperature in month t;

$R_t$  as the rainfall in month t;

$P_t$  as the population size in month t;

$\hat{P}_t$  as the relative of population growth in month t:

It is assumed that:

$$Y_t \sim \text{Poisson}(\mu_t)$$

where  $\mu_t$ , the logarithm of its expected value in month t; that is modeled by a linear combination of the auto regressive term of dengue fever cases, the rainfall, the average temperature, and the (estimated) population size.

Poisson regression was developed to further assess correlation between DHF case and rainfall and temperature. The assumptions in Poisson Regression includes:

- 1) Logarithm of the disease rate changes linearly with equal increment increases in the exposure variable.
- 2) Changes in the rate from combined effects of different exposures or risk factors are multiplicative.
- 3) At each level of the covariates the number of cases has variance equal to the mean.
- 4) Observations are independent.

Based on data availability, we propose seven Poisson regression models for predicting the number of dengue fever cases, which are given as follows. The predictors of Model 1 and Model 2 are the monthly cumulative rainfall, the monthly average temperature, and the (estimated) monthly population size. Meanwhile the predictors of Model 3 and Model 4 are the monthly cumulative rainfall, the monthly average temperature, and the (estimated) rate of population growth. In Model 5 and Model 6, we set the population size as a set off, and the predictors are the monthly cumulative rainfall and the monthly average temperature. In model 7, we do not use population data and the predictors are the monthly cumulative rainfall and the monthly average temperature. The best model is established by calculating Root Mean Square Error (RMSE), Standard Deviation (SD), and Akaike Information Criteria (AIC). The preferred model is the one with the minimum RMSE, SD and AIC value.

## (2) Compartment Model

A compartment model provides a framework for the study of transport between different compartments of a system. In epidemiology, models of the behavior of an infectious disease in a large population of people consider each individual as being in a particular state. These states are often called compartments, and the corresponding models are called compartment models. DHF, malaria, and diarrhea are such infectious diseases that can be analyzed by this compartment model. A compartment model uses a deterministic approach as illustrated in Figure 3.1. The Compartment model shows the circular process between healthy and sick people. The mosquitoes are the outer factor which carried the virus in the first place. Then the non-virus carrier mosquitoes could become the carrier when it bites the sick person. There are two important variables, so called the  $b$  and  $\mu$ . The  $b$  refers to the power of mosquitoes to bite, while the  $\mu$  is the possibilities of people to get infected by the dengue virus. Two coefficient variables depend on the spatial, climatic or social context.

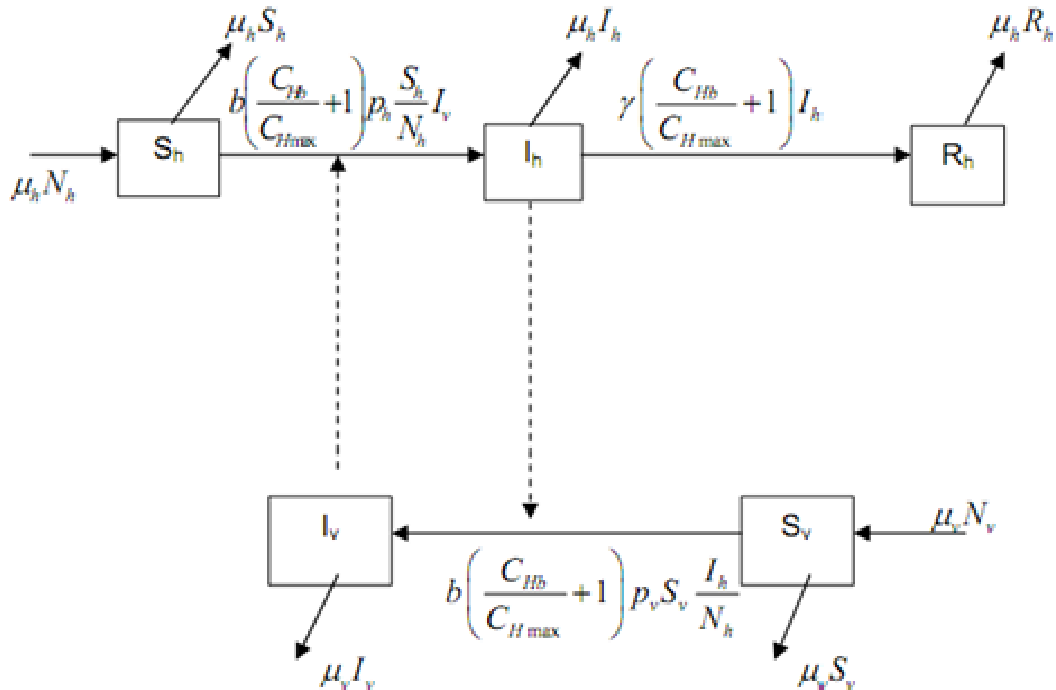

Figure 3. 3 Schematic of the compartment modeling of DHF

This study assumes that a person can be in one of three states, e.g. susceptible (S), infectious (I) or recovered (R). Individuals move from the Susceptible state (S) to the Infectious state (I) by mixing or interacting with infectious individuals/vectors. After exposure to microparasitic infection, individuals who recover (R) from a disease will enter a third state where they may be immune to subsequent infection. Since these three compartments S (for susceptible), I (for infectious) and R (for recovered) are standard convention labels, this model is also called the SIR model.

DHF, malaria, and diarrhea are infectious diseases that can be analysed by the compartment model. We include the temperature and rainfall effect in this compartment model by making assumptions in the case of DHF and malaria:

- The seasonal nature of transmission may reflect the influence of climate on the transmission cycle.
- Increases in temperature and precipitation can lead to increased abundance of mosquitos by increasing their development rate, decreasing the length of reproductive cycles, stimulating egg-hatching, and providing sites for egg deposition.
- Higher temperature further abets transmission by shortening the incubation period of the virus in the mosquito
- Mosquito species are responsible for transmission and they are sensitive to temperature changes as immature stages in the aquatic environment and as adults.
- If water temperature rises, the larvae take a shorter time to mature and consequently there is a greater capacity to produce more offspring during the transmission period.
- In warmer climates, adult female mosquitoes digest blood faster and feed more frequently, thus increasing transmission intensity.

- Malaria parasites and viruses complete extrinsic incubation within the female mosquito in a shorter time as temperature rises, thereby increasing the proportion of infective vectors.
- Changing rainfall patterns can also have short and long term effects on vector habitats.
- Increased rainfall has the potential to increase the number and quality of breeding sites for mosquitoes and the density of vegetation, affecting the availability of resting sites.

In diarrhea case, we assume the effects of rainfall and temperature is as follow:

- Climate change could greatly influence water resources and sanitation in situations where water supply is effectively reduced.
- Temperature and relative humidity directly influence the rate of replication of bacterial and protozoan pathogens and the survival of enteroviruses in the environment.

### 3.3 Methodology for Dynamic Vulnerability Analysis

The vulnerability assessment in this study is conducted differently from previous studies (Nusa Tenggara Barat Climate Risk and Adaptation Assessment), by incorporating the changing conditions of variables being measured. Thus it is called the dynamic vulnerability assessment. In order to guide the analysis, several rules are established as attributes of the dynamic vulnerability framework in this study. Those rules are as follows:

- Indicators used in the vulnerability assessment in each sector are different.
- The unit of analysis for some indicators assessed at provincial level may also be different with the ones at district level. For Meso Level MSA (province) the unit of analysis is district or subdistrict. Meanwhile, for Micro Level MSA (district), the unit of analysis is subdistrict or village.
- For some indicators in which the spatial data (image) is available the actual size from the image is used in the analysis.
- For indicators that are dynamic in nature, its change in pattern may be used to project its future condition.

From consultation with experts of all sectors (Coastal, Water, and Health), indicators that are used in the vulnerability assessment, using the equation that vulnerability (V) is a function of exposure (E), sensitivity (S) and adaptive capacity (AC), are in the table below. Indicators that are dynamic in nature, and thus their change may be analyzed in the vulnerability assessment, are marked as D.

Table 3.4 Indicators for Vulnerability Assessments

Hazard Type	VA Components	Indicators
<b>Coastal: Inundation</b>	Exposure	Land use (D) Urban population density (population per urban area) (D) Critical infrastructure (D)
	Sensitivity	Elevation Slope
	Adaptive capacity	<i>(assumed to be homogeneous along Tarakan</i>



Hazard Type	VA Components	Indicators
		<i>coastal areas)</i>
<b>Water: Flood and Landslide</b>	Exposure	Urban population density (population per urban area) (D) Land use (D)
	Sensitivity	Function and status of critical infrastructure (D)
	Adaptive capacity	People's welfare (housing type and income per capita) (D) Drainage (flood) or road (landslide) network (D)
<b>Water: Shortage</b>	Exposure	Demand for water provision (D)
	Sensitivity	Type of water resources Water quality
	Adaptive capacity	People's welfare (housing type and income per capita) (D) PDAM network (As proxy to access to drinking water) (D)
<b>Health: Dengue</b>	Exposure	Urban population (D)
	Sensitivity	Type of water supply (with PDAM or not) (D) Urban population density (D) People's mobility (D)*
	Adaptive capacity	Provision of health facility (D) Accessibility to health facility (D)
<b>Health: Malaria</b>	Exposure	Population living near breeding site (swamp ricefield, forest, or inundated areas) (D)
	Sensitivity	Distance to breeding site Availability of mangrove area (D) Type of housing (permanent or not) (D) Sensitive population (fisherman, fish farmer, forester) (D)*
	Adaptive capacity	Provision of health facility (D) Accessibility to health facility (D)
<b>Health: Diarrhea</b>	Exposure	Urban population (D)
	Sensitivity	Type of sanitation (toilet or not) (D) Type of water supply (PDAM or not) (D) Prolonged flood area Proportion of sensitive population (infant and senior) (D)
	Adaptive capacity	Immunization program (D) Provision of health facility (D) Availability of clean water (PDAM network) (D)

Note: \* is not used in the analysis due to lack of data.

At the time of vulnerability analysis for each hazard, the value of each indicator may be different, thus in order to assign weight for each indicator for each hazard, two methods may be used, i.e. expert judgment and analytical hierarchical process (AHP). The expert judgment method is simpler; the sector's expert determines the weight for each indicator based on the expertise. The AHP method involves several steps, starting from developing a questionnaire based on the list of indicators, distributing the questionnaire to experts familiar with the substance (at least three, including the sector's expert), inputting the responses to the questionnaire into a computer program called Expert Choice, then running the program, with the result being the weight of each indicator.

### 3.4 Methodology for Risk Analysis

Risk analysis is conducted with a basic model of risk as a function of hazard and vulnerability. There are two types of risk calculated in this study, one is the current risk as a baseline, and another one is the future risk that takes into account climate projection in year 2030. The current risk is measured based on current hazard and vulnerability, while the future risk is measured based on projected hazard using IPCC SRES A1B scenario and projected vulnerability. In projecting vulnerability, two main data sources are used, i.e. anything related to spatial data such as land use and road network, the Spatial Structure and Pattern Plans in the Local Spatial Plan document is used as reference. Furthermore, anything related to population or population projection 20 years from the current year is calculated using the available annual growth rate.

For both risk assessments, the risk level is determined from the combination of hazard and vulnerability levels as illustrated in the chart below.

Table 3.5 Chart for Risk Analysis

		HAZARD				
		Very Low	Low	Moderate	High	Very High
VULNERABILITY	Very Low	VL	VL	L	L	M
	Low	VL	L	L	M	H
	Moderate	L	L	M	H	H
	High	L	M	H	H	VH
	Very High	M	H	H	VH	VH

### 3.5 Methodology for Adaptation Formulation and Prioritisation

Climate change adaptation according to UNFCCC (2008: 10) is “a process through which societies make themselves better able to cope with an uncertain future”. Thus, “adapting to climate change entails taking the right measures to reduce the negative effects of climate change (or exploit the positive ones) by making the appropriate adjustments and changes”. Basically there are two categories of adaptation: reactive, in which immediate actions are required, and anticipatory, which could take more time to implement. In developing adaptation option for each hazard, the sector’s experts work based on risk maps resulting from the risk analysis, either for the baseline or future condition. From the risk maps, a typology of an area can be observed, based on its characteristics. The sector’s experts look at this typology and then outline recommendation for adaptation options. Those options may consist of hard or soft adaptation measures. The basic principle in outlining the adaptation options is that in order to reduce risks from climate change, the adaptation should aim at reducing the vulnerability, which means either reducing the exposure and sensitivity, or increasing the adaptive capacity. Thus when outlining the adaptation options, the sector’s experts must always review the conditions of each indicator

used in the dynamic vulnerability assessment in order to identify correctly the cause of vulnerability or risk that one area has.

The compilation of risk assessment and adaptation options from all sectors would be used as the basis for adaptation area prioritisation. For this purpose, first a multi-risk map is generated and then overlaid with the current land use map (for baseline) and the land use plan map (for future condition). Adaptation prioritisation would then follow several principles, either for current or projected risk. The key principles are:

- Whether risk exists on single or multiple sectors
- Whether risk occurs on strategic area or not
- Whether risk affects large area or not

Series of the results of risk analysis of all sectors are overlaid to highlight areas where multiple climate risks occur at high and/or very high level. The areas are then identified as prioritized areas for climate change adaptation.

In addition, for mainstreaming of the CCRAA into development plans, prioritisation of adaptation options is also resulted from stakeholders' consultation where preferred adaptation options are assessed. Tools used in this consultation are (1) the Hedonic-Qualitative Cost Benefit Analysis (HQCBA) worksheet and (2) the Importance Level Rating (ILR) matrix. The stakeholders identify what factors that determine the likelihood of executing the proposed adaptation option into real action. The preferred adaptation for each sector is determined either based on the result of HQCBA worksheet (the highest score option) or the ILR matrix (the most rated option).

## 4. Risk Assessment and Adaptation Options in Coastal Sector

### 4.1 Results of Hazard Analysis

#### 4.1.1 Characteristics of Hazard Elements

Inundation or flooding hazard in coastal areas of Tarakan is not only induced by global sea level rise but also by other variable factors such as tides, variability of ENSO/ La Niña, storm surges, wind waves, and tsunami. These hazard elements of sea level changes have characteristics as follows.

Table 4.1 Elements of Hazards Related to Sea Level Changes

Element of Hazards	Hazard code	Frequency	Level of consequence	Return period	Remark
Global Sea Level Rise	3	Increase	Low	incrementally	Projection
Tidal (HHWL)	1	Frequent	Low	Monthly	Tidal Prediction
ENSO/La Niña	4	Less frequent	Low	2-3 years	Prediction
Storms Surges	6	Less frequent	High	Annual	Statistical
Wind waves	2	Frequent	Moderate	Seasonally	Prediction
Tsunami	7	Rare	High	>50 years	Model

Values of these hazard elements are obtained by assessment of supporting scientific data of oceanography in Tarakan (Sofian, 2010) for moderate SRES A1B.

Table 4.2 Elements of Hazards Related to Sea Level Changes for SRES A1B

Item/Year	2030	2050	2080	2100
<b>Tidal Range</b>	3.1m/3.5m	3.1m/3.5m	3.1m/3.5m	3.1m/3.5m
<b>Sea Level Rise</b>	14.7 ± 6.25cm	26.0 ±11.0cm	48.0 ±22.0cm	65.5 ±28.5cm
<b>La Niña</b>	15cm	15cm	15cm	15cm
<b>Surges</b>	30 cm	30 cm	30 cm	30 cm
<b>Wind wave</b>	1.3m (estimation)	1.2m	1m	1.m

*Note: The wind waves are based on the annual daily maximum wave height, due to the IPCC wind projection that only available for daily.*

#### 4.1.2 Cumulative Hazard Map

A cumulative hazard map is an illustration or information about potential cumulative hazards related to climate change that could simultaneously affect the coastal areas of Tarakan.

To determine hazard level, we define 2.10 m above MSL (the HHWL and significant wave height) as the threshold between high and very high levels to represent boundary of conformity for community livelihood in Tarakan coastal areas.

Further analysis will be focused on the scenario-3 of the year 2030 as it represents extreme conditions that would be occur at least once in three years.

In scenario-3, the flooding or inundation hazard due to sea-level rises causes large impacts on both penetration distances from shoreline and inundation coverage area. Large scale impacts could be forced to locations in several coastal villages, especially Juata Laut, Karang Anyar Pantai, Karang Harapan, Mamburungan, dan Pantai Amal, dan Juata Permai.

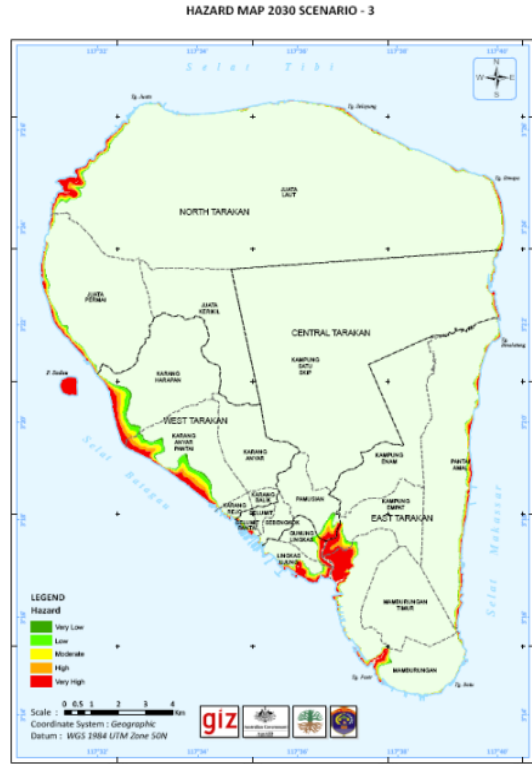

Figure 4.1 Inundation Map of Scenario-3

Table 4.3 Inundated area, distance, and shoreline in selected villages having largest and second largest coastal inundation hazard impacts in 2030

Subdistricts/ Villages	Area (Ha)	Inundation in 2030		
		Distance (km)	Shoreline (km)	Area (Ha)
<b>East Tarakan</b>				
Mamburungan	851	1.555	20.99	123.00
Pantai Amal	1215	0.268	14.62	118.00
<b>Central Tarakan</b>				
<b>West Tarakan</b>				
Karang Anyar Pantai	851	0.983	6.06	222.00
Karang Harapan	1221	0.925	5.83	188.50
<b>North Tarakan</b>				
Juata Permai	1423	0.418	8.48	107.84
Juata Laut	8454	1.052	32.39	236.84

## 4.2 Results of Vulnerability Analysis

Vulnerability assessment is conducted by normalizing each vulnerability element (topography, topographic slope, land use, population density, and vital infrastructure) into the level of vulnerability. Each element of vulnerability is weighted according to the level of sensitivity to the sea-level hazards, in order to obtain an aggregate of all of vulnerability elements being considered (see figures below).

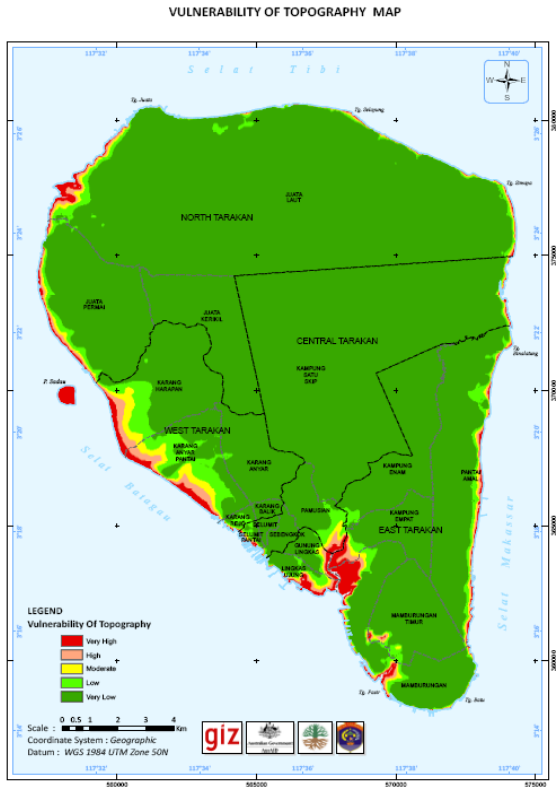

Figure 4.2 Vulnerability Map of Topography

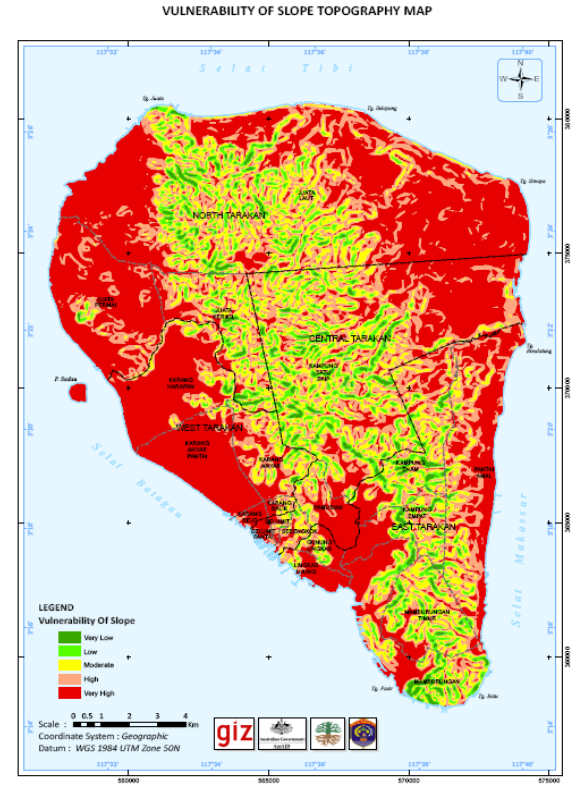

Figure 4.3 Vulnerability Map of Topographic Slope

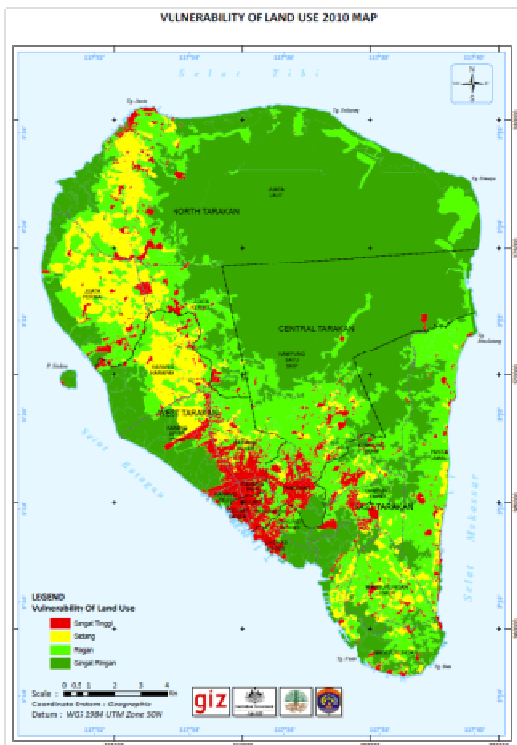

Figure 4.4 Vulnerability Map of Land Use 2010

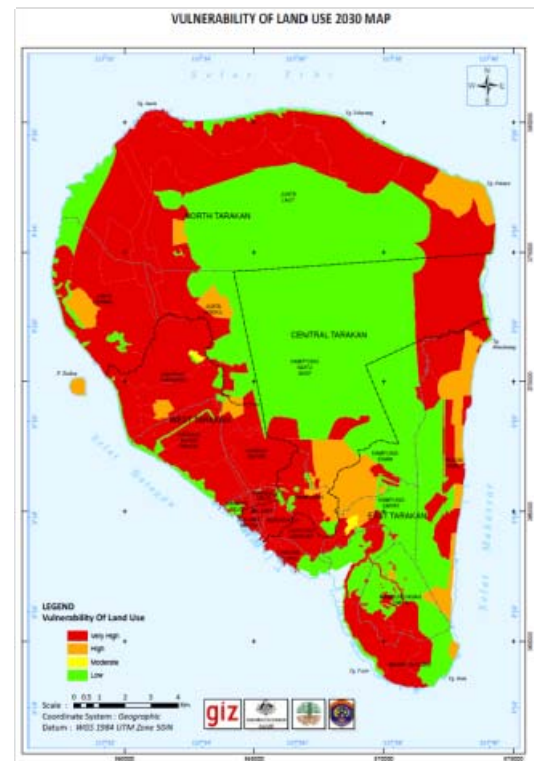

Figure 4.5 Vulnerability Map of Land Use 2030

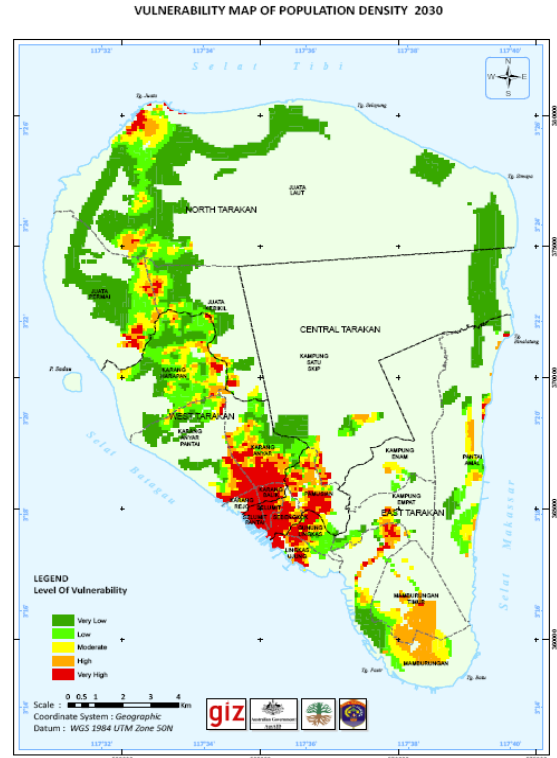

Figure 4.6 Vulnerability Map of Population Density 2030

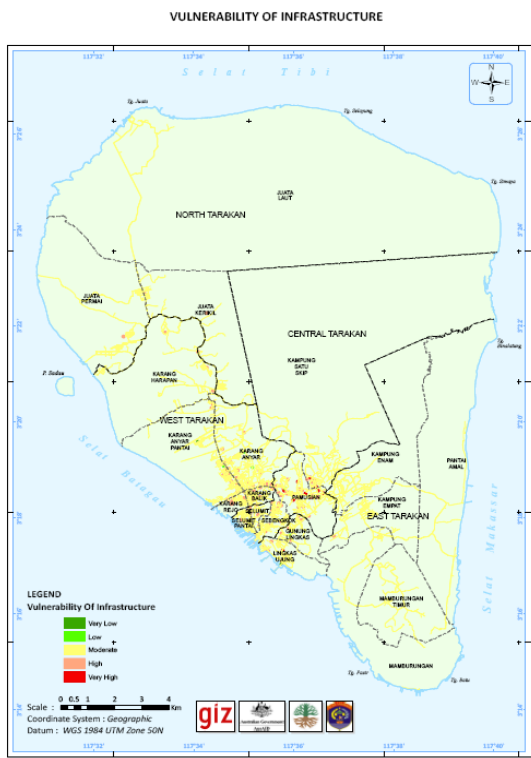

Figure 4.7 Vulnerability Map of Infrastructure and Critical Facility 2010

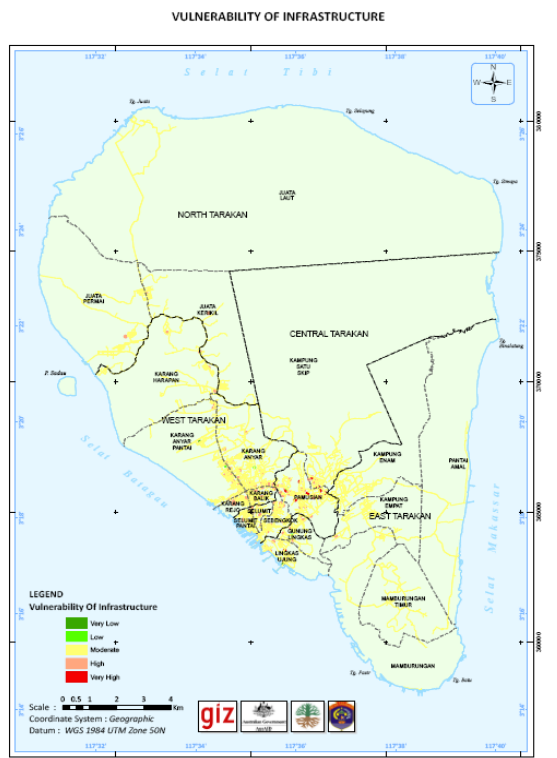

Figure 4.8 Vulnerability Map of Infrastructure and Critical Facility 2030

An aggregate of all vulnerability elements is calculated considering the sensitivity of each element which is represented by the weight normalisations. These weights are

obtained by pairwise comparison between elements that are judged by the expert using the Analytical Hierarchical Process (AHP) method.

Table 4.4 An aggregate and weighting of all vulnerability elements

Vulnerability Elements		Vulnerability Elements					Weight	Weight Normalisation
		LU	P	Inf	E	ST		
Land Use	LU	1.00	1.00	2.00	3.00	4.00	11.00	0.31
Population Number	P	1.00	1.00	2.00	3.00	4.00	11.00	0.31
Infrastructure and Critical Facilities	Inf	0.50	0.50	1.00	2.00	3.00	7.00	0.20
Elevation	E	0.33	0.33	0.50	1.00	2.00	4.17	0.12
Topographic Slope	ST	0.25	0.25	0.33	0.50	1.00	2.33	0.07
<b>Total</b>							<b>35.50</b>	<b>1.00</b>

Finally, the aggregate map of all elements for 2010 and 2030 are shown in two figures below respectively.

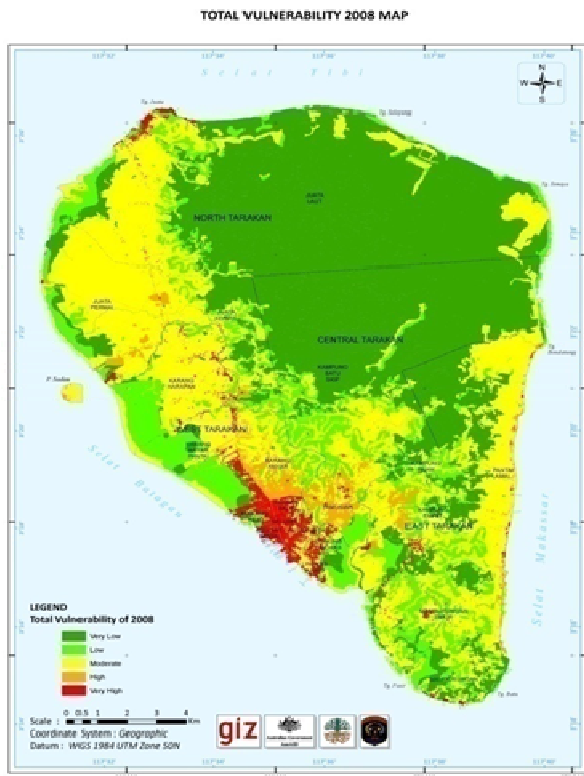

Figure 4.9 Aggregate map of all vulnerability in 2008

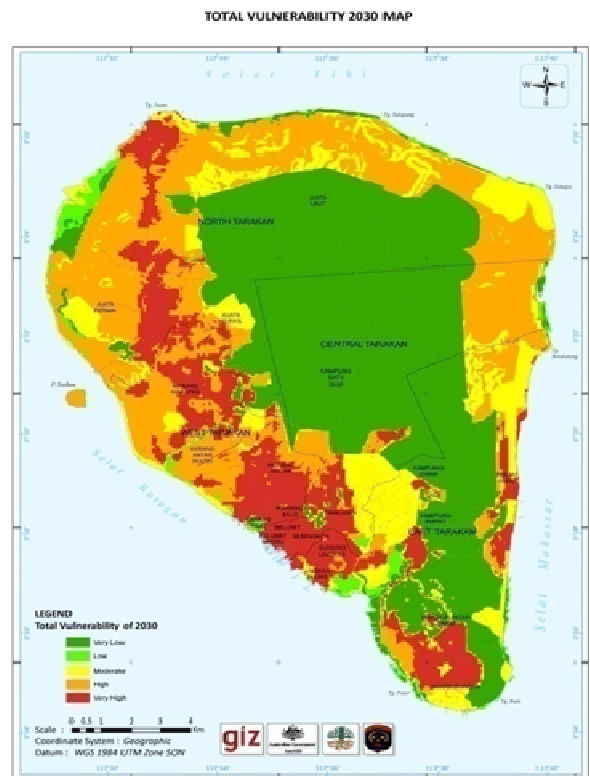

Figure 4.10 Aggregate map of all vulnerability in 2030

Both figures show the most vulnerable areas depicted in red followed by orange colours. In baseline conditions, these areas are merely located to the south west of Tarakan, and some areas in Juara Permai (west) and Juara Laut (north). These areas would broaden due to Spatial Planning 2030 into villages along western Tarakan and in Pantai Amal (eastern coast).



### 4.3 Results of Risk Analysis

#### 4.3.1 Risk Level Mapping

Risk analysis is important to see how large potential risks would impact the coastal area of Tarakan City. Thus we would be able to determine the level of risk that might occur in the region. This assessment performs the estimation of the level of risk in accordance with the levels of hazard and vulnerability by using a relation table in **Error! Reference source not found.** as follows.

		HAZARD				
		Very Low 0-0.5m	Low 0.5-1.0m	Moderate 1.0-1.5m	High 1.5-2.1m	Very High x>2.1m
VULNERABILITY	Very Low	VL	VL	L	L	M
	Low	VL	L	L	M	H
	Moderate	L	L	M	H	H
	High	L	M	H	H	VH
	Very High	M	H	H	VH	VH

Figure 4.11 Scheme for estimating the risk level

In this analysis, the potential risks are assessed by developing a related risk level map for the year 2030. The risk level map in the Tarakan coastal areas in 2030 is developed by overlaying the hazards map of scenario-3 (Figure 4.1) and the aggregated vulnerability maps (Figure 4.10) as shown in Figure 4.12 below. In summary, there are five villages having a very high level of risk, i.e, Lingkas Ujung, Kampung Empat, and Gunung Lingkas in East Tarakan tsubdistrict as well as Sebengkok and Selumit Pantai in Central Tarakan subdistrict. This very high level of risk in these villages is mainly caused by the high level of hazard in inundated areas.

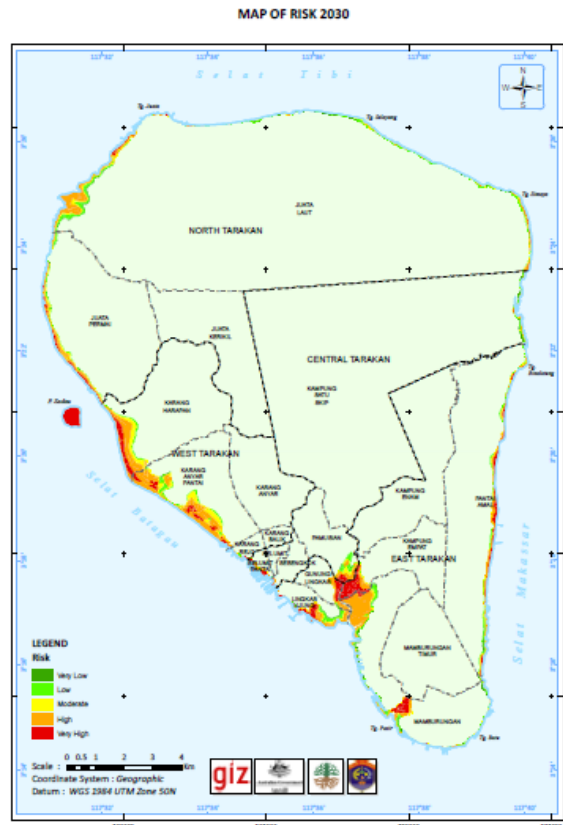

### 4.3.2 Impact of Risk on Spatial Planning

With the aim of analysing which types of land use will be inundated in the future, the hazard map of scenario-3 is overlaid with the Spatial Pattern Map as a part of Spatial Planning for year 2029 as shown in figure below. The risk analysis and risk level of each land use element are summarized and listed in table below.



Figure 4.13 Overlay between Hazard Map of Scenario-3 and Spatial Plan 2029

From these figures and tables, it can be seen that all of the five very risky villages comprise settlements with high population density. Some vital infrastructures and facilities are also contained in these areas, such as an oil refinery in Lingkas Ujung, mining, military, and industrial areas in Kampung Empat, a trade zone and military areas in Selumit Pantai and Sebengkok. In of its function as offering soft protection by vegetation, the mangrove forest located in Lingkas Ujung and Gunung Lingkas, and the city forest in Kampung Empat, Selumit Pantai and Sebengkok are most important; so they should be maintained and restored.

Table 4.5 Summary of Risk Map in Selected Villages Year 2030

Subdistricts/ Villages	Area (Ha)	Number of Population in 2010	Inundation in 2030			Facilities and Land Use Type	Inundated Area (Ha) in 2030	Risk Level
			Distance (km)	Shoreline (km)	Area (Ha)			
<b>East Tarakan</b>	<b>5904</b>	42.909		46.27				
Lingkas Ujung	116	10.409	0.719	10.49	62	Oil Refinery, High Pop Density Mangrove Forest	- 23.36 38.85 <b>4.18 (VH)</b>	
Gunung Lingkas	319	7.905	0.573		30	High Pop. Density Mangrove Forest	21.92 8.33 <b>4.05 (VH)</b>	
Mamburungan	851	7.633	1.555	20.99	123	High Pop Density Tourism Area Warehouse Area, Military Area Industrial Area Mangrove Forest, City forest	6.61 1.72 25.81 3.11 80.33 5.45 - <b>3.53 (H)</b>	
Kampung Empat	1139	4.529	1.173	-	56	Public Facility, Sport Center, High Pop Density Mining Area, Military Area, Industrial Area , City forest, Mangrove Forest	- - 36.54 - 18.58 - 1.43 - <b>4.18 (VH)</b>	

Subdistricts/ Villages	Area (Ha)	Number of Population in 2010	Inundation in 2030			Facilities and Land Use Type	Inundated Area (Ha) in 2030	Risk Level
			Distance (km)	Shoreline (km)	Area (Ha)			
Kampung Enam	1121	5.433	-	-	-	Public Facility, Greenbelt, High Pop Density Mining Area, Trade zone, Education Zone, Protected Forest, City forest	-	-
Mamburungan Timur	1040	2.531	0.113	0.17	1.67	Landfills, Medium Pop Dens. Tourism Area, Military Area, City forest	- - 0.28 0.92	3.24 (H)
Pantai Amal	1215	4.469	0.268	14.62	118	High Pop Density Tourism Area, Fisheries Zone, Trade Zone, Education Zone, Mangrove Forest, City forest	41.53 69.17 - - 7.31 0.31	3.69 (H)
<b>Central Tarakan</b>	<b>5593</b>	<b>60.397</b>		<b>17.21</b>				
Selumit Pantai	48	16.347	0.467	7.15	17.5	High Pop. Density Trade Zone, Military Area, City Forest	17.41 - 0.18 -	4.26 (VH)
Selumit	43	6.490	-	-	-	High Pop. Density , Trade zone	-	-
Sebengkok	148	15.019	0.466	4.98	4.5	High Pop Density Trade Zone, Military Area, City forest	0.79 3.94 - -	4.45 (VH)
Pamusian	254	14.131	0.810		44.5	Public Facility, High Pop Density , Mining Area, Trade Zone, Industrial Area, Mangrove Forest, City forest	10.59 5.72 - 3.83 - 24.24 -	3.25 (H)
Kampung Satu Skip	5061	8.410	0.295	5.08	6.5	Public Facility, Greenbelt, Medium Pop. Dens. Mining Area, Military Area, Mangrove Forest, Conserv. Forest	- - 1.11 - - 5.40 -	2.57 (M)
<b>West Tarakan</b>	<b>2934</b>	<b>67.780</b>		<b>14.22</b>				
Karang Balik	80	6.856	-	-	-	High Pop. Density Trade zone, City forest,	-	-
Karang Rejo	76	7.875	0.234	2.33	6.15	High Pop. Density Trade Zone, Industrial Area, City forest Mangrove Forest	1.62 - 1.83 0.22 2.70	3.82 (H)
Karang Anyar	561	27.573	-	-	-	Juata Airport, High Pop. Density Mining Area, Trade Zone, Military Area, Protected Forest, Mangrove Forest, City Forest	-	-
Karang Anyar Pantai	851	17.855	0.983	6.06	222	Juata Airport, High Pop Density Mining Area, Trade Zone,	20.30 108.92 - -	3.70 (H)

Subdistricts/ Villages	Area (Ha)	Number of Population in 2010	Inundation in 2030			Facilities and Land Use Type	Inundated Area (Ha) in 2030	Risk Level
			Distance (km)	Shoreline (km)	Area (Ha)			
						Education Zone, Military Area, Mangrove Forest, City forest	10.20 - 62.42 15.27	
Karang Harapan	1221	7.621	0.925	5.83	188.50	Nursery Barn Medium pop. Dens. Livestock zone, Trade Zone, Industrial Area, Mangrove Forest, City forest Tourism Area	25.71  98.23 21.95 36.24	3.56 (H)
<b>North Tarakan</b>	<b>10649</b>	<b>21.983</b>		<b>40.87</b>				
Juata Permai	1423	6.877	0.418	8.48	107.84	Medium Pop. Dens. Livestock zone, Trade Zone, Government zone, Industrial Area, Mangrove Forest, City forest	66.74 38.91	3.06 (H)
Juata Kerikil	1059	4.705	-	-	-	Landfills, High Pop Density Mining Area, Trade Zone, Protected Forest, City forest	-	-
Juata laut	8454	10.401	1.052	32.39	236.84	Cemetrey, Landfills, Greenbelt, High Pop Density Tourism Area, Mining Area Trade Zone, Govern. zone, Industrial Area, Mangrove Forest, Protected Forest, City forest	- - - 13.54 13.38 - - - 19.45 172.30 - -	2.94 (M)

#### 4.4 Adaptation Option

It is intended that the development of adaptation strategies for Tarakan City should be planned and implemented in an efficient way; i.e. somewhat appropriate and avoid mal-adaptation. Therefore, the adaptation concept is being developed based on the level of risk, types of vulnerability, and its regionalism (combination of ecosystem and condition of built environment), rather than the administrative division of the city itself. Development of adaptation options also takes into a consideration a prioritisation process of prioritisation and measurement of compatibility with the Tarakan City development plan. This will be discussed later in Chapter 8.

The adaptation concepts can be seen in Figure 4.14, where the Tarakan coastal areas are divided into three regions of adaptation strategies, while brief descriptions of each region are as follows:

- Region A (north coast), which typically comprises dense forests, wetlands, and mangroves along Juata Laut villages. As a result, adaptation concepts to be proposed to this region are mainly coastal forest and mangrove restoration

(living shoreline) followed by accommodation – protection strategy for these settlements in the villages, especially in northeast part of Juata Laut village.

- Region B (west coast), which has typical dense population (settlements) and economic activities, planned governmental and industrial zones, and also containing some wetlands and mangroves. Concepts of adaptation proposed in this region are accommodation – protection strategy followed by mangrove restoration (living shoreline).
- Region C (east coast), which will mainly be developed as coastal tourism areas (Pantai Amal) in the future as it has benefit of sandy beach. However, development in this region is constrained by potentially high abrasion or erosion as it is exposed to daily high wind waves and storm surges coming from the Makassar Strait. Therefore, the concept of an integrated coastal zone management (ICZM) is proposed to be implemented in this region, especially by three major adaptation actions, i.e.: managed realignment, coastal setback, and hard and soft coastal protection.

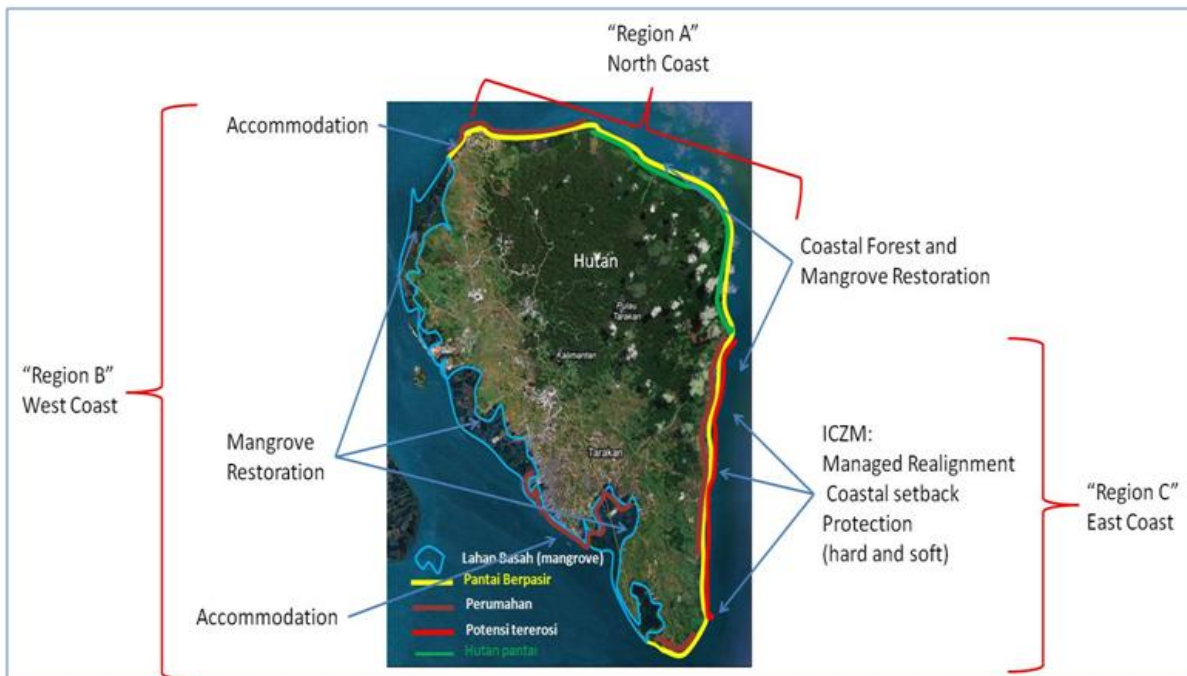

Figure 4.14 Regionalism for Adaptation in Coastal Area of Tarakan City

These adaptation concepts are implemented in the villages along coast of Tarakan City that are summarized in the following Table 4.6:

Table 4.6 Summary of Adaptation Strategies in Selected Villages

Adap-tation Region	Sub-District	Villages	Risk Level	Adaptation Strategies
<b>North Coast Region (A)</b>	<b>North Tarakan</b>	Juata Laut	<b>M</b>	<ul style="list-style-type: none"> <li>• Coastal forest restoration at <u>northern and eastern parts</u></li> <li>• Accomodation and protection (for planned settlements and industrial zones)               <ul style="list-style-type: none"> <li>- Raising house and building levels</li> <li>- Evaluation of harbor level</li> </ul> </li> </ul>
<b>West</b>	<b>North</b>	Juata Permai	<b>H</b>	<ul style="list-style-type: none"> <li>• Planning (with considering inundated zones in</li> </ul>

Adap-tation Region	Sub-District	Villages	Risk Level	Adaptation Strategies
Coast Region (B)	Tarakan			the governmental and industrial zone plannings) <ul style="list-style-type: none"> <li>Protection (mangrove restoration)</li> </ul>
	West Tarakan	Karang Rejo	H	<ul style="list-style-type: none"> <li>Accomodation <ul style="list-style-type: none"> <li>- Raising house and building levels</li> <li>- Development of flood proofing</li> <li>- Raising bank/dike levels of fishponds</li> </ul> </li> <li>Protection (Mangrove restoration)</li> </ul>
		Karang Anyar Pantai	H	
		Karang Harapan	H	
	Central Tarakan	Selumit Pantai	VH	<ul style="list-style-type: none"> <li>Accomodation <ul style="list-style-type: none"> <li>- Raising house and building levels</li> <li>- Development of flood proofing</li> </ul> </li> <li>Protection: <ul style="list-style-type: none"> <li>- Sea wall, sea dike, jetty, APO, detached breakwater</li> <li>- Beach nourishment, sand dune restoration,</li> <li>- Coastal forest (pinus)</li> </ul> </li> <li>Planning: ICZM (integrated Coastal Zone Management) <ul style="list-style-type: none"> <li>- Managed realignment</li> <li>- Coastal setback</li> </ul> </li> </ul>
		Sebengkok	VH	
		Pamusian	H	
		Kampung Satu Skip	M	
	East Tarakan	Lingkas Ujung	VH	<ul style="list-style-type: none"> <li>Accomodation: Raising house and building levels</li> <li>Protection (sea wall)</li> <li>Wetland restoration (mangrove reforestation)</li> </ul> (There is no coastline; inundation enters via estuary of the Pamusian river) <ul style="list-style-type: none"> <li>Protection (river banks)</li> </ul>
		Gunung Lingkas	VH	
		Kampung Empat	VH	
		Mamburungan	H	
	East Coast Region (C)	East Tarakan	Mamburungan	H
Pantai Amal			H	
Central Tarakan		Kampung Satu Skip	M	

## 5. Risk Assessment Result and Adaptation Options in Water Sector

### 5.1 Results of Hazard Analysis

There are three hazards that being are assessed in the water sector; i.e. flood, landslide, and water shortage. The climatic drivers, temperature and precipitation, and projection are used for hydrology and groundwater modelling. On the other hand, there are also nine non-climatic drivers that are calculated in the hazard analysis; i.e. population density, land use, water demand, water quality, PDAM network, infrastructure, government's programmes, and society welfare. On the other hand, flood hazard uses HECRAS as its analytical method for modeling with climate driver and land use change as a parameter. Finally, for landslide, GEOSLOPE was used for modeling and the climate drivers and land use change are used as parameters. For water shortage, the study uses water balance and FEM water as its modeling and incorporates climate drivers, population growth, and land use change as its main parameters for projection.

#### 5.1.1 Hazard Analysis for Flood

In hazard analysis for flood, the WMS modeling was used for 12 watersheds from the total 20 watersheds in Tarakan City, both for the baseline and projection situation. Table 5.1 and Figure 5.1 below shows that the flood area will significantly increase especially in Karungan (from 0,997 km<sup>2</sup> in 2010 to 1,806 km<sup>2</sup> in 2030), Pamusian (from 1,154 km<sup>2</sup> in 2010 to 5,974 km<sup>2</sup> in 2030), Persemaian (from 0,962 km<sup>2</sup> in 2010 to 1,82 km<sup>2</sup> in 2030), Semunti (from 0,164 km<sup>2</sup> in 2010 to 2,139 km<sup>2</sup> in 2030), and the Sesanip watershed (from 0,425 km<sup>2</sup> in 2010 to 2,051 km<sup>2</sup> in 2030). Following the estimation of flood hazard analysis based on the watershed, those data are then reclassified based on its administrative area. Administratively, Juata Village has the largest inundation area (3.313 km<sup>2</sup>) that comes from 3 watersheds; i.e. Semunti, Maya, and Mangantai watersheds. Kampung Enam Village could experience the second largest projected inundation area (2.648 km<sup>2</sup>) from the Binalatung and Kuli watersheds.

Table 5. 1 Flood Hazard Area of Tarakan

No.	Rivers/Basins	Flood Hazard Baseline Area (km <sup>2</sup> )	Flood Hazard Projection 2030 Area (km <sup>2</sup> )
1	Semunti	0.164	2,139
2	Bengawan	1.231	1,549
3	Persemaian	0.962	1,82
4	Sesanip	0.425	2,051
5	KampungBugis	0.789	1,605
6	Pamusian	1.154	5,974
7	Karungan	0.997	1,806
8	AmalBaru	0.154	0.461
9	Kuli	1.207	1,486
10	Binalatung	1.145	1,802
11	Mangantai	0.516	0,713



No.	Rivers/Basins	Flood Hazard Baseline Area (km <sup>2</sup> )	Flood Hazard Projection 2030 Area (km <sup>2</sup> )
12	Maya	3.083	3,618

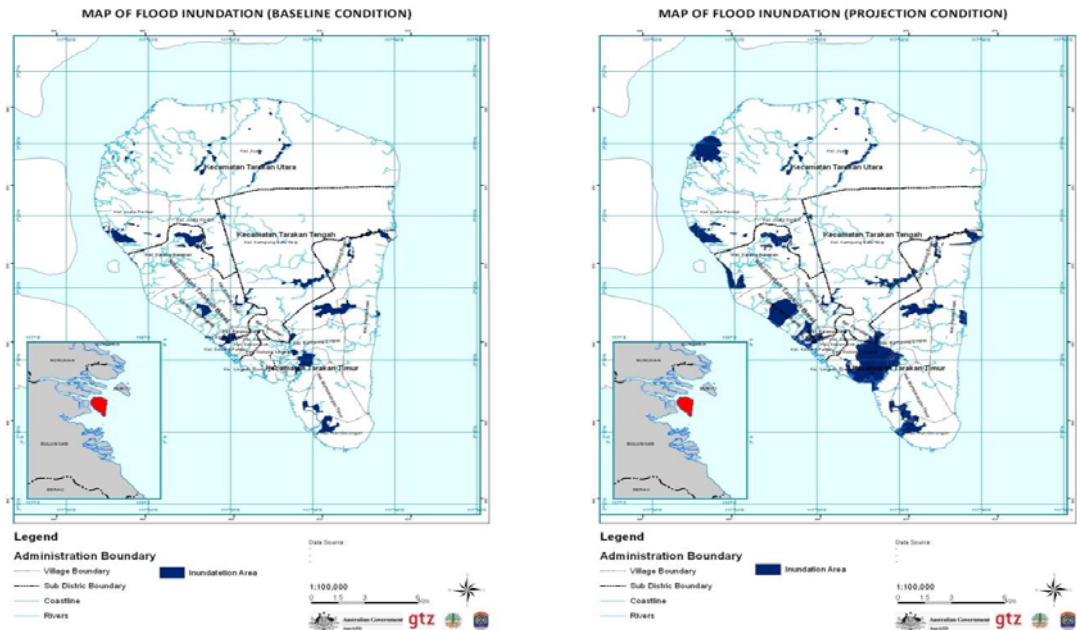

Figure 5.1 Flood Risk in Baseline and Projection Condition

Source: Water Sector Report, Setiawan, 2011

In projection conditions, the flood hazard will inundate 18 villages, as shown in Table 5.2.

Table 5.2 Floodplain Area in Projection Hazard of Tarakan

District	Village	Floodplain Area (km <sup>2</sup> )	Watershed of Flood Area
Tarakan Utara	JuataKerikil	0.123	
	JuataPermai	0.952	
	Juata	3.313	Semunti
Tarakan Tengah	SelumitPantai	0.072	
	Pamusian	0.111	
	KampungSatuSekip	0.964	
Tarakan Barat	KarangAnyar	0.163	
	KarangAnyarPantai	0.32	
	karangBalik	0.012	
	KarangHarapan	0.964	
	KarangRejo	0.423	
Tarakan Timur	KampungEmpat	0.992	
	KampungEnam	0.897	
	PantaiAmal	2.165	
	Mamburungan	2.648	
	MamburunganTimur	0.693	

District	Village	Floodplain Area (km <sup>2</sup> )	Watershed of Flood Area
	GunungLingkas	1.311	
	Lingkas Ujung	0.928	

### 5.1.2 Hazard Analysis for Landslide

Hazard analysis for landslide was basically based on the relation between rainfall, various hydrometeorology and topographic factors, soil characteristics, and depth of water. The earliest part of landslide hazard analysis was done through the calculation of Ground Water Table (GWT) recharge estimation using the Cumulative Rainfall Distribution method; i.e. baseline conditions using 2001 – 2010 rainfall data and the two parts of projection, i.e. 2011 – 2020 and 2021 – 2030. The model for landslide hazard is then developed by the utilisation of the extreme rainfall concept and unique relationships between rainfall characteristics, hydraulic conductivity, suction, and water content of unsaturated soil; i.e. used to evaluate the minimum suction distribution and safety factor of the slope. In addition, the slope geometry and shear strength of soil were also taken into account. The development of the landslide model was conducted by estimating the decrease of cohesion value indicating that the extreme rainfall infiltrates the ground water then changes the unsaturated condition to the saturated one of the soil. The Digital Elevation Map (DEM) of Tarakan City was then built to estimate the type of landslide and impacted area based on its elevation. Afterwards, modeling through Geostudio v6.2 was also accomplished to estimate the safety factor; i.e. an effort to calculate the relative factor of safety between extreme rainfall and dry conditions. Thus, the baseline conditions for landslide hazard were completed.

In order to conduct landslide hazard analysis for projection conditions, estimation of GWT recharge from 1 – 5 m below the surface was done, thus resulting in the decrease over GWT recharge value around 1 -2; i.e. indicating the recharge of GWT as an impact of climate change is causing landslide. Afterwards, landslide hazard analysis is modeled through prediction of the amount of rainfall that infiltrates the slope. Its infiltration may impair the slope's stability, by changing the pore water pressure which in turn controls the water content of the soil itself. The prolonged rainfall infiltration reduces matrix suction of soil which in turn decreases the soil shear strength, and subsequently triggers the slope failure.

The landslide model for Tarakan City has been performed for both baseline and projection conditions. In the baseline condition, landslide hazard is located in 13 different locations; i.e. 4 locations in North Tarakan Subdistrict, 2 locations in West Tarakan Subdistrict, 4 locations in Central Tarakan subdistrict, and 3 locations in East Tarakan Subdistrict (as shown in Figure 5.2 below). As for projection conditions, there are 13 different locations that may expect landslide incidence. However their probabilities are different, thus being classified into the level of low, moderate, high, to very high as shown in Figures below.

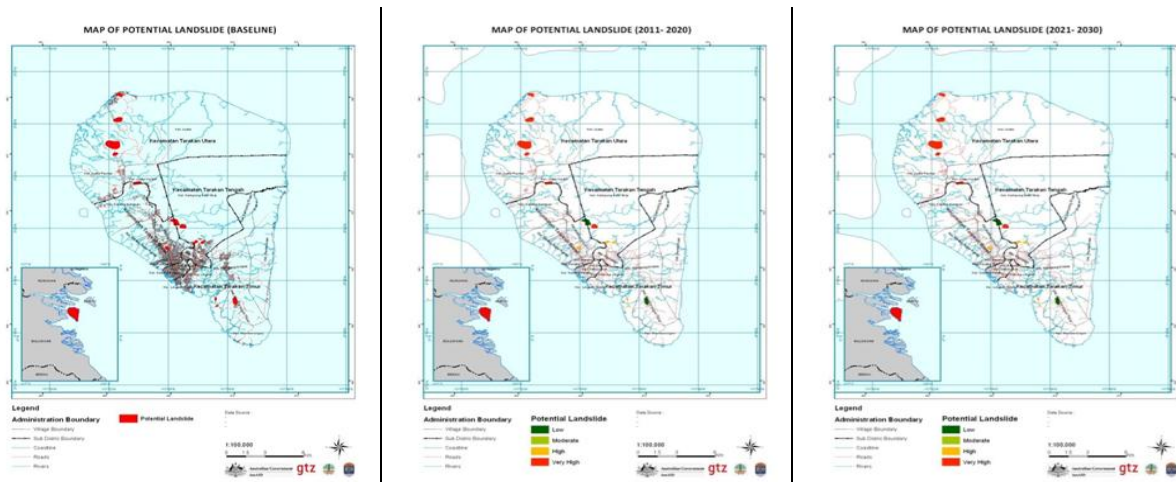

Figure 5.2 Results of Landslide Hazard Modelling  
 (Baseline condition, Projection Year 2010 – 2020, and Projection Year 2020 – 2030)  
 Source: Water Sector Report, Setiawan, 2011

### 5.1.3 Hazard Analysis for Water Shortage

Water shortage hazard can basically be defined as the probability of a state in which water supply or water availability may be reduced; i.e. the total probability of the water availability decreasing from the baseline data compounded with the increase in water demand. The probability is being assessed by CDF analysis towards the value of Total Runoff (TRO) where the CDF percentage is 50%. Based on the analysis, it can be seen that the TRO was consistently decreasing from the baseline conditions (1960 – 1990) towards current conditions (1991 – 2020); i.e. will decrease around 180 mm/year or 8%. In addition the decreasing rate from 1991 – 2020 to 2010 – 2030 was around 267 mm/year or approximately 12%.

The rate of water demand in Tarakan City can basically be categorized as non-climatic drivers that may increase the exposure level to the hazard; which in this context is water shortage. There are two calculations that are needed to determine rate of the water demand; i.e. domestic and industrial water demand. The domestic water demand is being calculated through the utilisation of population data and number of families for each watershed, thus multiplied by the standard water demand. On the other hand, the industrial and other economic activities demand is calculated by utilising current land use and planned future land use, thus a water demand value is assigned for each land use type. After the calculation is completed, the water shortage hazard analysis is produced through a GIS system as given below:

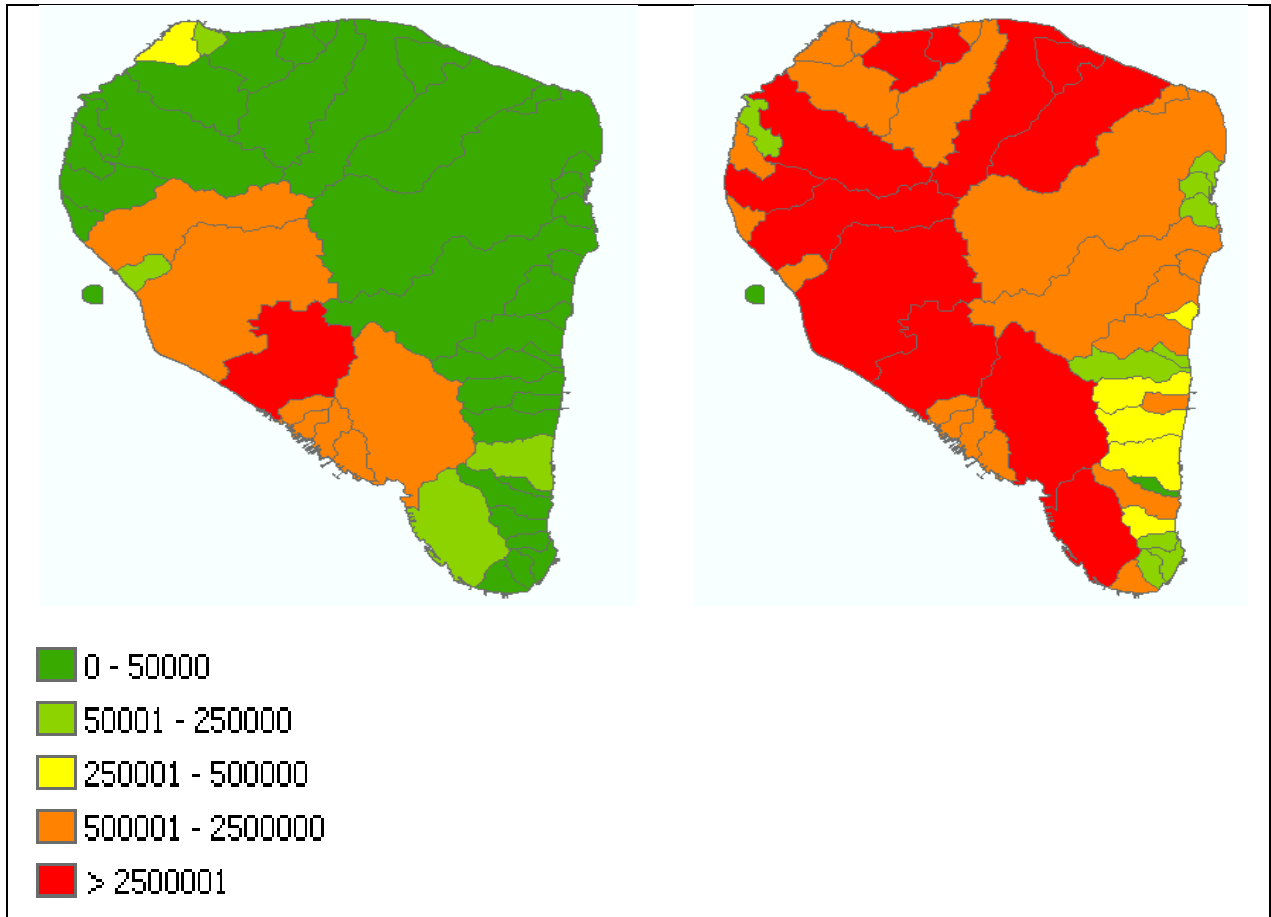

Figure 5.3 Water Demand Calculations for Tarakan City

Source: Water Sector Report, Abdurrahman et al, 2011

Water shortage and water demand values for each watershed are used as hazard indicators, and then compared with the baseline condition. Therefore, the map of water shortage hazard results from the overlaying of the Decreasing of Water Availability (DoWA) added to rate of Water Demand (WD), compared with the total number of water in the baseline conditions. The map of water shortage hazard is given below for both baseline and projection conditions.

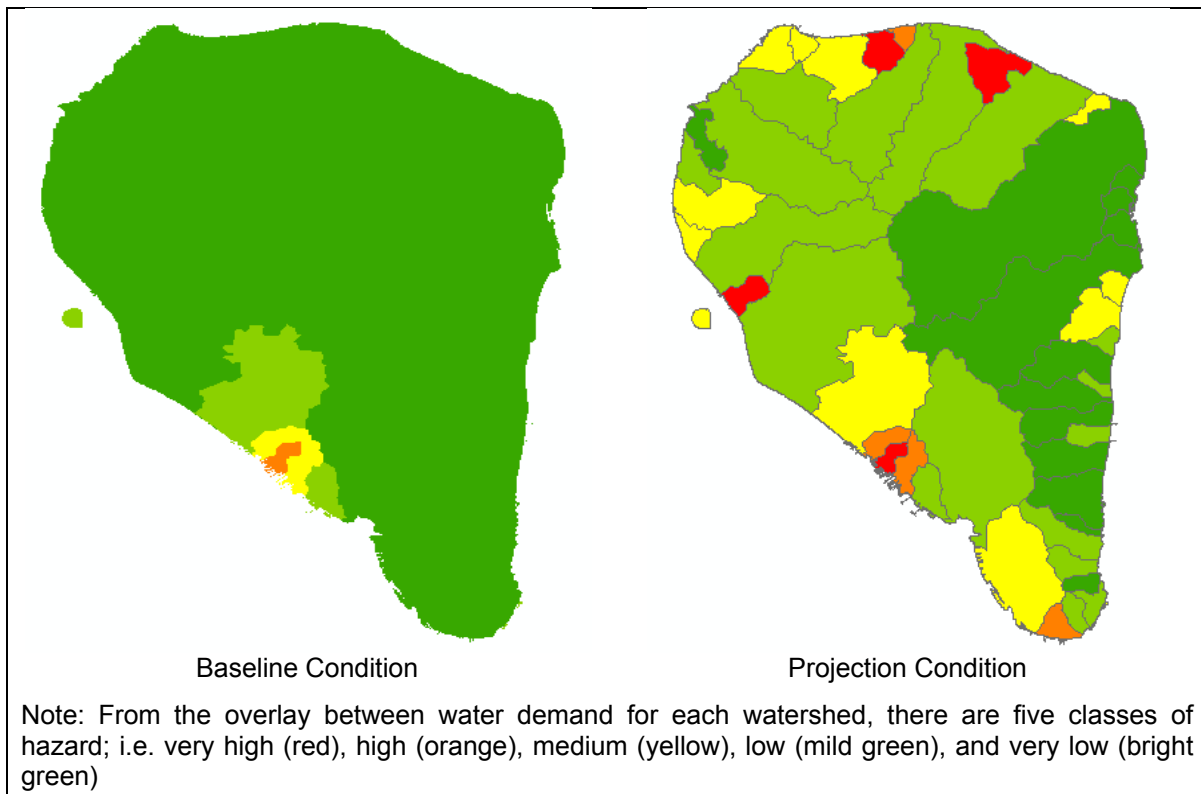

Figure 5.4 Map of Water Shortage Hazard

Source: Water Sector Report, Abdurrahman et al, 2011

As it can be seen from the figure above, basically there will be an increase in terms of water shortage hazard from current towards future conditions. For current conditions (1990 – 2010), the very high level of water shortage hazard may happen in Kampung Bugis watershed; i.e. due to the decrease in natural water supply from the increase in evapo-transpiration, and the increasing of water demand.

## 5.2 Results of Vulnerability Analysis

Vulnerability analysis for water sector in Tarakan City was performed for nine primary components; i.e. population density, land use, infrastructure, water demand, water quality, government programs, PDAM services, and social welfare. Vulnerability basically is specific to hazard; therefore there are also differences between vulnerability components for flood and landslide with water shortage. Vulnerability components for flood and landslide are population density, land use, vital infrastructure, social welfare, and drainage network; as for water shortage the vulnerability components are water demand, water resource, water quality, social welfare, and PDAM network. For each vulnerability component, analyses for both baseline (year 2010) and projection (year 2030) have been done.

### 5.2.1 Vulnerability Analysis of Flood Hazard

Vulnerability analysis to flood hazard was carried out incorporating 5 components; i.e. population density and land use for exposure component, role of infrastructure for sensitivity component, and population welfare (society's income and house type) as well as government program for adaptive capacity. Weighting for each component as

a result of the pair-wise comparison done by water sector experts are given in the table below.

Table 5. 3 Weighting of Vulnerability Component for Flood Hazard

Component	Indicator	Sub Indicator	Weighting
Exposure	Population Density		0.344
	Land use		0.259
Sensitivity	Role of Infrastructure		0.182
Adaptive Capacity	Population Welfare	Society income	0.051
		House Type	0.092
	Government Program		0.072

Source: Water Sector Report, Abdurrahman et al, 2011

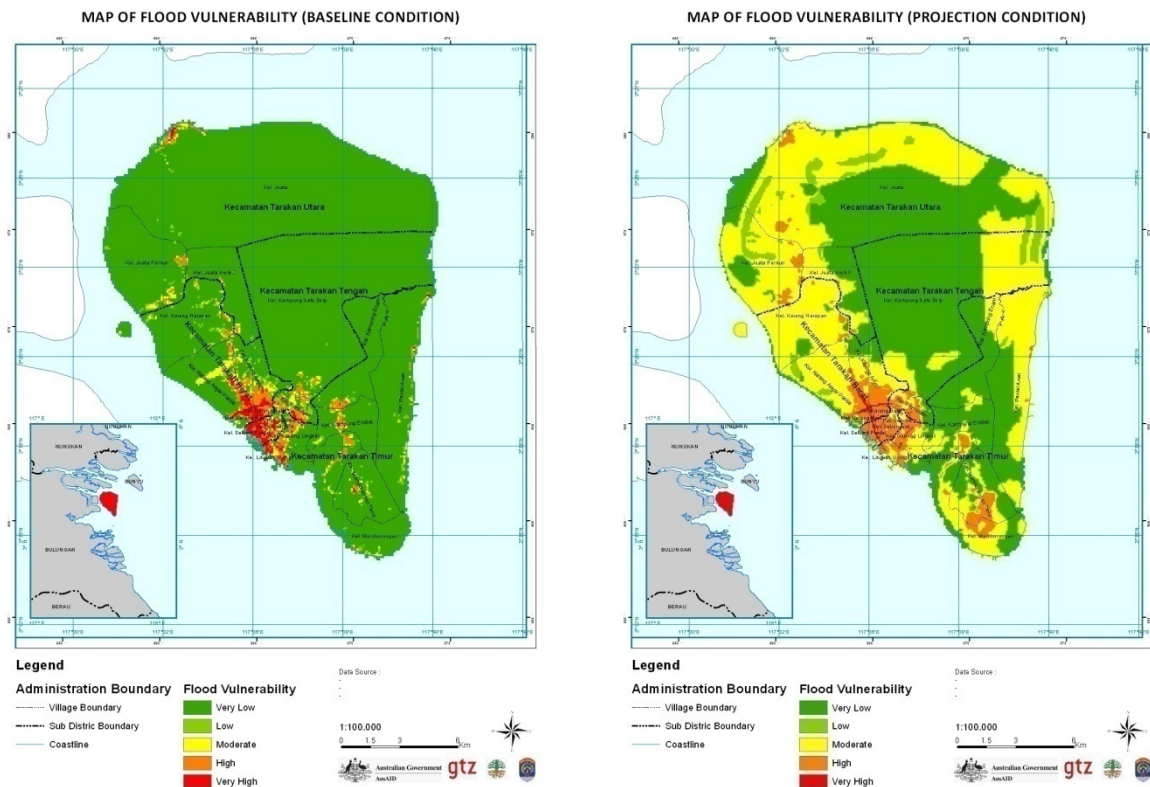

Figure 5.5 Vulnerability of Floods in Baseline and Projection Condition

Source: Water Sector Report, Abdurrahman et al, 2011

### 5.2.2 Vulnerability Analysis of Landslide Hazard

Vulnerability analysis for landslide hazard was carried out incorporating 5 components that are same as the components being used for vulnerability analysis for flood; i.e. population density and land use for exposure component, role of infrastructure for sensitivity component, and population welfare (society's income and house type) as well as government program for adaptive capacity. Weighting the

result for each component as a result from the pair-wise comparison done by water sector experts are given in the table below.

Table 5. 4 Weighting of Vulnerability Component for Flood Hazard

Component	Indicator	Sub Indicator	Weighting
<b>Exposure</b>	Population Density		0.380
	Land use		0.242
<b>Sensitivity</b>	Role of Infrastructure		0.157
<b>Adaptive Capacity</b>	Population Welfare	Society income	0.070
		House Type	0.087
	Government Program		0.064

Regions which have increased vulnerability include those which will be developed into settlement areas. This is because the population and land use weight become dominant., more than 80%. Tarakan City land use plan does not accommodate non settlement areas, thus all developed areas become more vulnerable to landslides. . The weighting of the indicator in the government programme is only 6,4%, causing an apparent similarity between landslides and floods vulnerability.

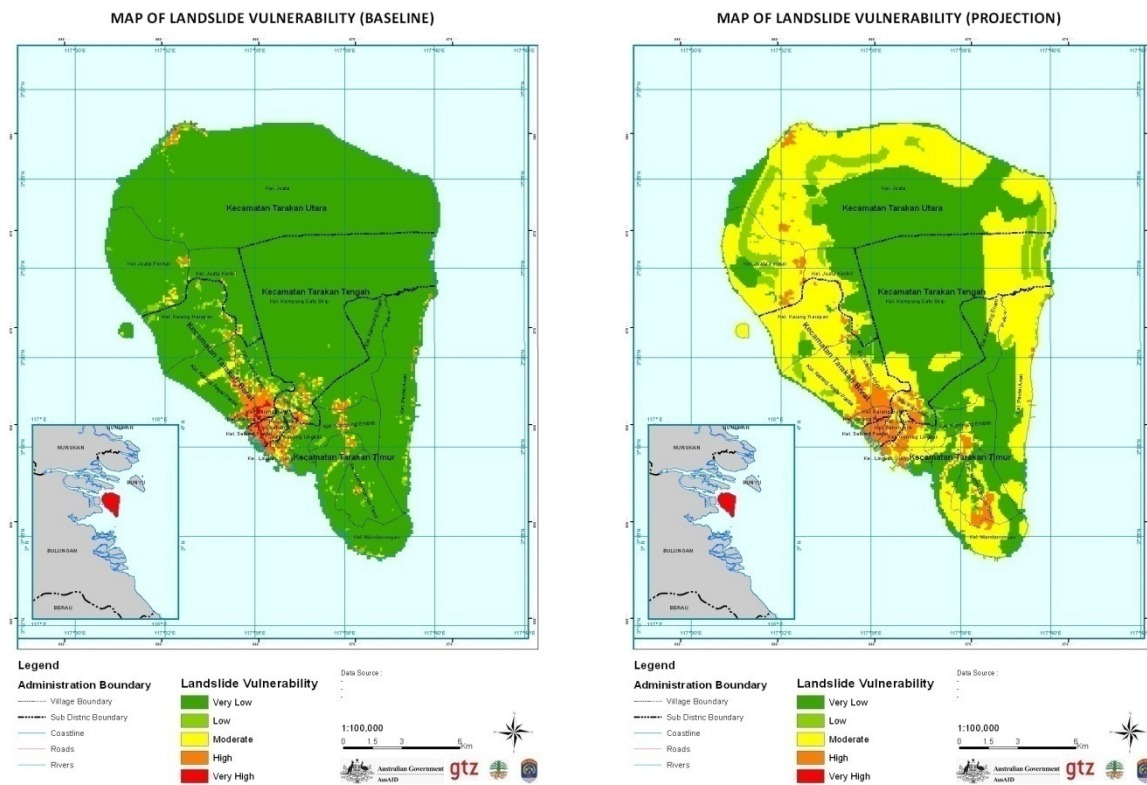

Figure 5.6 Vulnerability of Landslide in Baseline Condition and Projection Condition.  
Source: Water Sector Report, Abdurrahman et al, 2011

### 5.2.3 Vulnerability Analysis of Water Shortage Hazard

Vulnerability analysis respective to water shortage hazard was carried out incorporating 5 components; i.e. water demand for exposure component, water resource and water quality for sensitivity component, and population welfare (society's income and house type) as well as PDAM network for adaptive capacity. Weighting the result for each component as a result from the pair-wise comparison done by water sector experts are given in the table below.

Table 5. 5 Weighting of Vulnerability Component for Flood Hazard

Component	Indicator	Sub Indicator	Weighting
<b>Exposure</b>	Water Demand		0.278
	Water Resource		0.279
<b>Sensitivity</b>	Water Quality		0.175
<b>Adaptive Capacity</b>	Population Welfare	Society income	0.117
		House Type	0.087
	PDAM Network		0.064

From the figure below, it can be seen that in the baseline conditions, the highest vulnerable area is in the middle of Tarakan City, and in Selumit Pantai. Regions with high vulnerability level are Karang Anyar, Karang Anyar Pantai, Karang Rejo, Selumit Pantai, Sebengkok, and Juata Laut. But in the projection conditions, the vulnerability level increases along the developed coastal regions. Regions needing special attention are northern Juata Laut, Juata Permai, Karang Harapan, and Mamburungan which are developed into industrial and settlement areas.

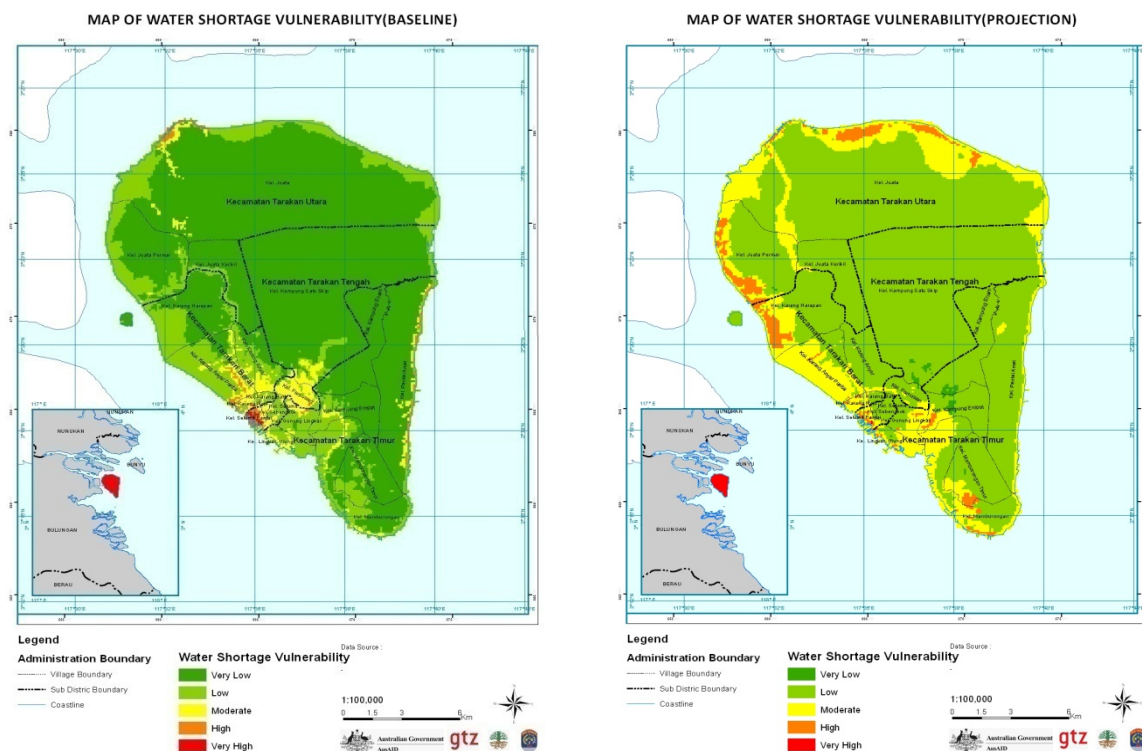

Figure 5.7 Vulnerability of Water Shortage in Baseline and Projection Condition.  
Source: Water Sector Report, Abdurrahman et al, 2011



### 5.3 Results of Risk Analysis

In this sub chapter, the result of risk analysis for Tarakan City in both baseline and projection will be given. Risk is a function of hazard and vulnerability (Affeltranger et al, 2006). In this context, risk level was divided into five levels; i.e. very low, low, moderate, high, and very high risk.

#### 5.3.1 Flood Risk

The result of flood risk analysis was given for each watershed that was assessed; i.e. 12 out of 20 total watersheds. There are several plausible changes in terms of risk level due to floods that may occur in each watershed; i.e. additional levels of hazard, increasing size of risk area, or combination of both possibilities. Table 5.6 below gives information regarding flood risk profile for both baseline and projection condition, containing information on size area of the risk level and land use characteristic for each level.

Table 5. 6 Flood Risk Profile in Tarakan City based on Watershed

No	Name of Watershed	Risk Profile on 2010		Risk Profile 2030	
		Size Area	Land Use	Size Area	Land Use
1	Semunti	Low Risk (0,553 km <sup>2</sup> )	Ponds, swamp, and mangrove	Very Low Risk (1.535 km <sup>2</sup> ) Low Risk (0,173 km <sup>2</sup> ) Moderate (0,740 km <sup>2</sup> )	Residential area (middle density)
2	Bengawan	Very Low Risk (1.382 km <sup>2</sup> )	Pond, mangrove, agriculture area	Very Low Risk (0,456 km <sup>2</sup> )	Mid-dense residential area and forest
		Low Risk (0,032 km <sup>2</sup> )	Residential area	Moderate Risk (1.133 km <sup>2</sup> mostly)	Industrial, high-dense residential area, and city forest
		Moderate Risk (0,011 km <sup>2</sup> )	Residential area	Very High Risk (0,030 km <sup>2</sup> )	
3	Persemaian	Very Low Risk (0,553 km <sup>2</sup> )	Shurb and Agriculture land	Very Low Risk (0,447 km <sup>2</sup> )	Middle Density Residential Area and City Forest
		Low Risk (0,226 km <sup>2</sup> )	Residential area and infrastructure	Low Risk (0,030 km <sup>2</sup> )	
		Moderate Risk (0,099 km <sup>2</sup> )		Moderate Risk (2.536 km <sup>2</sup> )	Industrial and High Density Residential Area
		High Risk (0,021 km <sup>2</sup> )		High Risk (0,158 km <sup>2</sup> )	
4	Sesanip	Very Low Risk (0,423 km <sup>2</sup> )	Pond	Very Low Risk (0,423 km <sup>2</sup> )	
		Low Risk (0,019 km <sup>2</sup> )	Cropland	Low Risk (0,130 km <sup>2</sup> )	High Density Residential Area
		Moderate Risk (0,050 km <sup>2</sup> )	Residential Area and Infrastructure	Moderate Risk (01,501 km <sup>2</sup> )	
		High Risk (0,030 km <sup>2</sup> )		High Risk (0,337 km <sup>2</sup> )	Juata Airport
		Very High Risk (0,031 km <sup>2</sup> )			

No	Name of Watershed	Risk Profile on 2010		Risk Profile 2030	
		Size Area	Land Use	Size Area	Land Use
5	Kampung Bugis	Very Low Risk (0,663 km <sup>2</sup> )	Residential Area	Very Low Risk (0,341 km <sup>2</sup> )	Residential and Commercial Area
		Low Risk (0,179 km <sup>2</sup> )		Low Risk (0,051 km <sup>2</sup> )	
		Moderate Risk (0,107 km <sup>2</sup> )		Moderate Risk (1,707 km <sup>2</sup> )	
		High Risk (0,110 km <sup>2</sup> )		High Risk (0,867 km <sup>2</sup> )	
		Very High Risk (0,261 km <sup>2</sup> )		Very High Risk (0,198 km <sup>2</sup> )	
6	Pamusian	Very Low Risk (2,219 km <sup>2</sup> )	Pond Area	Very Low Risk (3,336 km <sup>2</sup> )	Mangrove area
		Low Risk (0,184 km <sup>2</sup> )	Agriculture and shrub area	Low Risk (0,287 km <sup>2</sup> )	City Forest and Industrial Area
		Moderate Risk (0,242 km <sup>2</sup> )		Moderate Risk (2,536 km <sup>2</sup> )	
		High Risk (0,295 km <sup>2</sup> )	Residential Area and Infrastructure	High Risk (0,239 km <sup>2</sup> )	High-dense Residential Area
		Very High Risk (0,201 km <sup>2</sup> )		Very High Risk (0,089 km <sup>2</sup> )	
7	Karungan	Very Low Risk (0,945 km <sup>2</sup> )	Pond Area	Very Low Risk (0,163 km <sup>2</sup> )	Military activities
				Low Risk (0,008 km <sup>2</sup> )	
				Moderate Risk (0,622 km <sup>2</sup> )	
				High Risk (0,889 km <sup>2</sup> )	
8	Amal Baru	Very Low Risk (0,279 km <sup>2</sup> )	Shurbs, forest, and agriculture	Very Low Risk (0,181 km <sup>2</sup> )	Forest and Sport Area
		Low Risk (0,029 km <sup>2</sup> )	Residential area	Moderate Risk (0,411 km <sup>2</sup> )	Residential and Tourism Area
		Moderate Risk (0,010 km <sup>2</sup> )			
9	Kuli	Very Low Risk (1,714 km <sup>2</sup> )	Shurb and Forest area	Very Low Risk (1,487 km <sup>2</sup> )	City forest and Mid dense residential area
		Low Risk (0,012 km <sup>2</sup> )		Moderate Risk (0,412 km <sup>2</sup> )	
		Moderate Risk (0,010 km <sup>2</sup> )		High Risk (0,018 km <sup>2</sup> )	
10	Binalatung	Very Low Risk (2,291 km <sup>2</sup> )	Shurb, cropland, and forest	Very Low Risk (1,330 km <sup>2</sup> )	Forest and pond
		Low Risk (0,0085 km <sup>2</sup> )	Residential area	Low Risk (0,044 km <sup>2</sup> )	Mangrove
		Moderate Risk (0,02 km <sup>2</sup> )		Moderate Risk (1,796 km <sup>2</sup> )	Low and mid dense residential, tourism area

No	Name of Watershed	Risk Profile on 2010		Risk Profile 2030	
		Size Area	Land Use	Size Area	Land Use
				High Risk (0,050 km <sup>2</sup> )	Mid dense residential, tourism area
11	Mangantai	Very Low Risk (0,630 km <sup>2</sup> )	Forest Area	Very Low Risk (0,418 km <sup>2</sup> )	Forest Area
				Moderate Risk (0,258 km <sup>2</sup> )	Mid dense residential area
12	Maya	Very Low Risk (0,458 km <sup>2</sup> )	Forest area	Very Low Risk (0,418 km <sup>2</sup> )	Forest Area
				Low Risk (0,016 km <sup>2</sup> )	Tourism Area
				Moderate Risk (0,111 km <sup>2</sup> )	Tourism Area

Source: Summarized from Water Sector Report, 2011

### 5.3.2 Landslide Risk

Landslide risk modeling has been done through a simulation of ground water table fluctuation and estimation of the soil strength, thus it shows that the safety factor is decreased by the increasing ground water table and decreasing of soil strength. There are 4 levels of risk based on its safety factor, which is also determined by the slope stability. Safety factor level was defined using statistical methods. Afterwards, the probability of landslide was projected for 2011 – 2020 and 2021 – 2030 condition, as it can be seen in the Table 5.7 below.

Table 5. 7 Landslide Probability for 2011 – 2020 and 2021 – 2030 Projection

Landslide Probability for 2011 – 2020 Projection				Landslide Probability for 2021 – 2030 Projection					
Code	Coordinate		GWT Recharge (m)	Classification	Code	Coordinate		GWT Recharge (m)	Classification
	X	Y				X	Y		
R21	561122	373218	4840	High Risk	R21	561122	373218	3229	High Risk
R15	562346	369854	3562		R15	562346	369854	2395	Risk
R20	560270	378637	3510		R20	560270	378637	2354	
R16	561645	377558	3493		R16	561645	377558	2340	
R13	573029	368373	3468		R13	573029	368373	2320	
R14	563987	369439	3416		R14	563987	369439	2278	
R11	568135	365576	2479	Risk	R11	568135	365576	1652	Moderate
R12	568469	361480	2471		R12	568469	361480	1645	
R19	564263	366265	2468		R18	568593	364710	1643	
R17	571966	363894	2467		R17	571966	363894	1642	
R18	568593	364710	82	Low Risk	R19	564263	366265	77	

Source: Water Sector Report, 2011

Based on the probability information, the existing landslide classification can be defined. Afterwards, the map is overlaid with the land use map, both at current and future planned conditions based on the RTRW of Tarakan City. Therefore, the risk projection for landslide on 2011 – 2020 and 2021 – 2030 can be obtained (Figure 5.8).

Landslide risk analysis for baseline conditions indicated that North Tarakan Subdistrict has only very low level of risk; i.e. covering mangrove, bushes, farming, dry land farming, and field area. On the other hand Central Tarakan Subdistrict has very low to moderate level of risk, in which covers forest, bushes, farming, and field area. Moderate level of risk occurred in West Tarakan Subdistrict, dominated by field, bushes, farming, and some built area. As for East Tarakan, it is identified to have very low to moderate level of risk, thus it was covered by forest, bushes, farming, field, and some built area.

Based on the risk analysis for future projection, it can be seen that North Tarakan Subdistrict almost reaches the moderate level of risk in which the area is the place for medium to high dense residential area, industrial, and trading area. As for Central Tarakan Subdistrict, risk analysis for future conditions suggests that the area would contain very low to high level of risk, in which it may threaten the low and high density buildings and some protected forest that were planned to exist. On the other hand, West Tarakan Subdistrict will be facing high levels of landslide risk, in which it may threaten the future high density building and trading areas located in the district. East Tarakan is expected to only face low to moderate levels of landslide risk, in which the location will be dominated by medium density housing and trading areas.

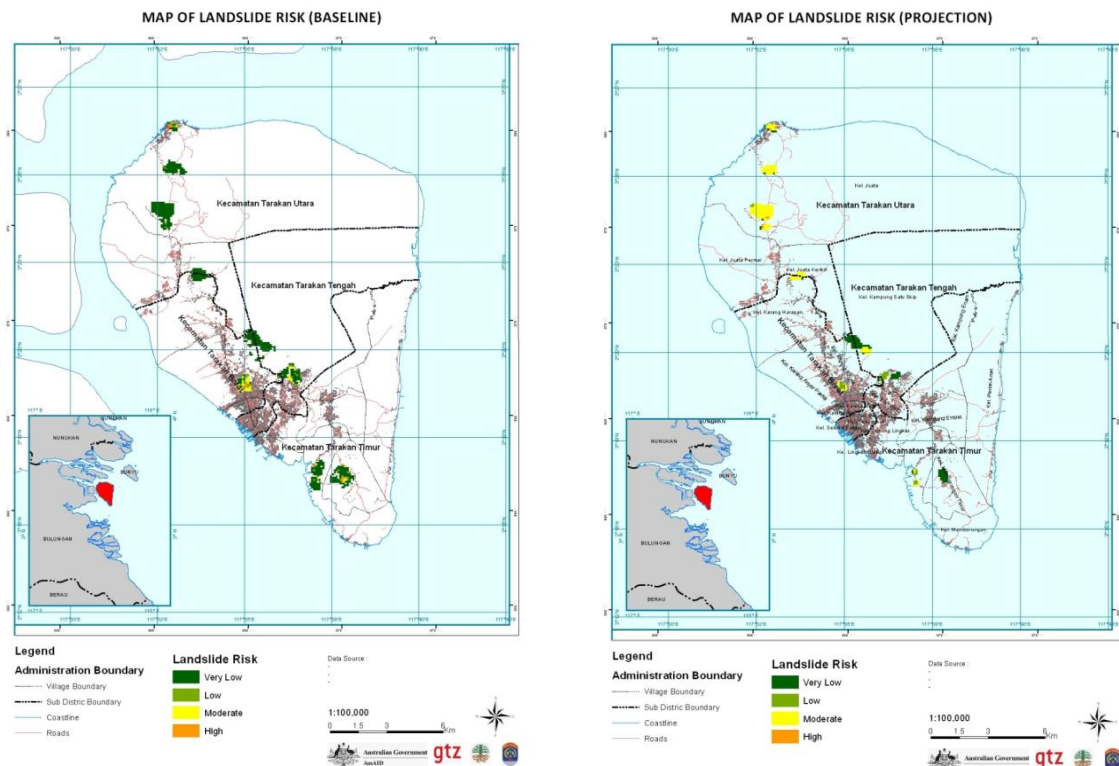

Figure 5.8 Landslide Risk for Baseline and Projection Condition.

Source: Water Sector Report, Abdurrahman et al, 2011

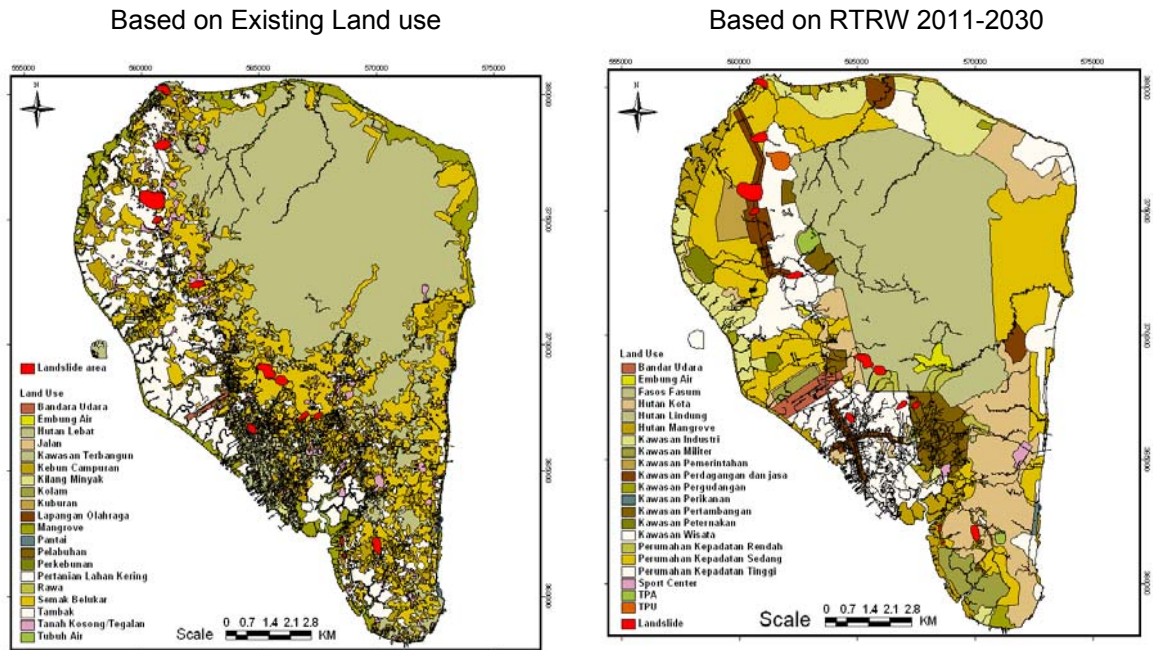

Figure 5.9 Overlay between Landslide Risk and Land Use Map

### 5.3.3 Water Shortage Risk

From the figure below, it can be inferred that the level of risk for water shortage is relatively low in the baseline period and increases slightly for the projection period. There are five levels of water shortage risk in Tarakan: very high, high, medium, low, and very low risks; with the widest spatial distribution risk of very low risk in the baseline period. In the projection period, there is a slight increase of low to high risks and an increase of area of medium and high risks, compared to previous period.

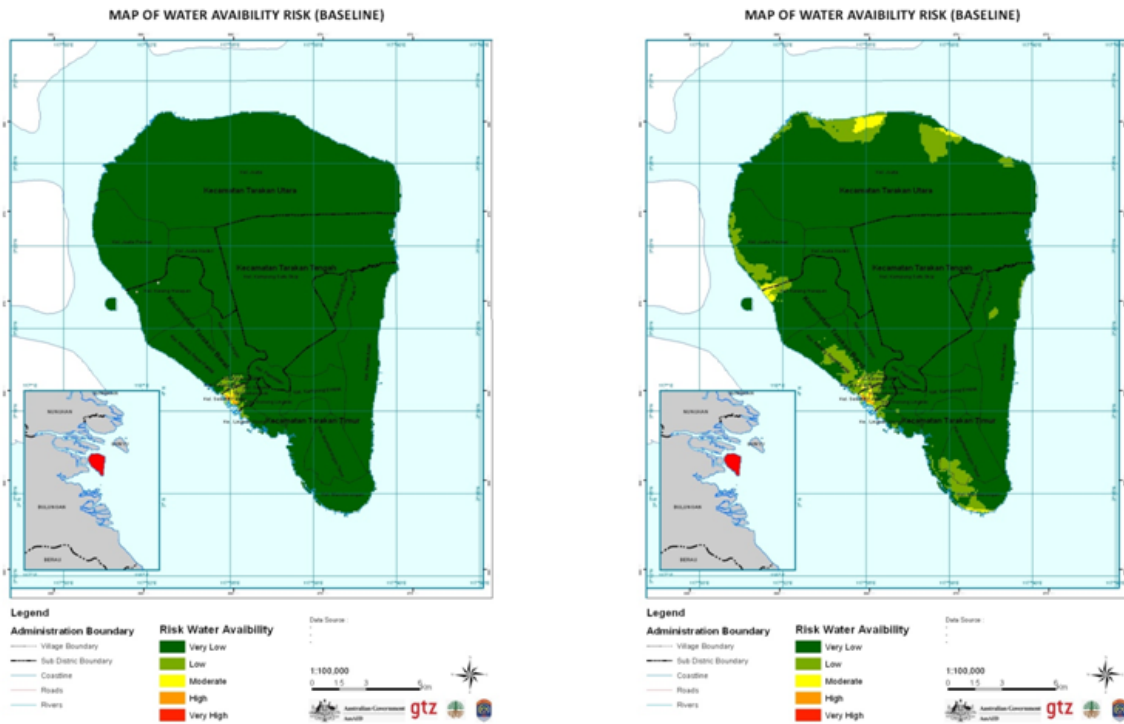

Figure 5.10 Risk Map of Water Shortage in Baseline and Projection Condition.  
Source: Water Sector Report, Abdurrahman et al, 2011

## 5.4 Adaptation Options

Adaptation options for overcoming risk of climate change in the water sector has been proposed for three types of hazard; i.e. flood, landslide, and water shortage. As a whole the concept of Integrated Water Resource Management (IWRM) can be considered as the main principle, in which are grouped both hard and soft adaptation measures that are possible to be implemented in Tarakan. As follows, here is the summary table of adaptation options for Tarakan, explaining its relation with climate change impact, position within the IWRM, type of adaptation, and status of the adaptation in the assessment.

Table 5. 8 Summary of Adaptation Options in Water Sector

Adaptation option in Tarakan's water sector	Impacts or Risk as Adaptation Targets	IWRM Management	Adaptation Options	Status in the assessment
Increase reservoir capacity	Water shortage	Supply side	Hard adaptation	EPI
Develop new reservoir or <i>embung</i>	Water shortage	Supply side	Hard adaptation	P
Desalinate	Water shortage	Supply side	Hard adaptation	P
Make inter-basin transfers (PDAM network)	Water shortage	Supply side	Hard adaptation	EPI
Harvest rainwater	Water shortage	Supply side	Hard adaptation	EPI
Build sluice gate (especially for western region)	Flood	-	Hard adaptation	EPI
Build reservoirs and levees	Water shortage Flood	-	Hard adaptation	P
Regulation related to flood for eastern region	Flood	-	Soft adaptation	EPI
Soil improvement (if possible in accordance with RTRW)	Landslide	-	Hard adaptation	P
Resettlement (if not according to RTRW)	Landslide	-	Hard adaptation	P
Capturing bureaucrat's views	Water shortage Flood Landslide	Supply side	Soft adaptation	P*
Capturing society's views	Water shortage Flood Landslide	Supply side	Soft adaptation	P*
Reshaping planning processes	Water shortage Flood Landslide	Supply side	Soft adaptation	P*
Coordinating land and water resources management	Water shortage Flood Landslide	Supply side	Soft adaptation	P**
Recognizing water quantity and quality linkages	Water shortage Flood Landslide	Supply side	Soft adaptation	P**
Conjunctive use of surface water and groundwater	Water shortage Flood	Supply side	Hard adaptation Soft adaptation	P**
Protecting and restoring natural systems	Water shortage Flood Landslide	Supply side		P**
Consideration of climate change	Water shortage Flood	Supply side		EPI

Adaptation option in Tarakan's water sector	Impacts or Risk as Adaptation Targets	IWRM Management	Adaptation Options	Status in the assessment
	Landslide			
Omitting the impediments to the flow of information.	Water shortage Flood Landslide	Supply side		P**

Note:

#: especially for water resources

EPI: Existing activity and proposed to be improved

P : Proposed activity

P\*: Has been done in this study, but needs to be maintained

P\*\* : Suggested, but the explanation steps are not yet discussed in this study

The following are recommended adaptation divided according to its risk.

### 5.4.1 Adaptation for Flood

According to Klein et al (1997), adaptation options to climate change can be divided into 3 levels; i.e. strategy, population, and individual level. For the Tarakan City context, the adaptation is more appropriate within the strategy level; i.e. focusing on the development and regulation to implement adaptation to climate change. There are 3 adaptation zones that being introduced to Tarakan City, in order to have effective measures for adaptation to flood risk. The zone assignment resulted from an overlay between existing land use, land use change based on Tarakan City RTRW 2011 – 2030, and inundation areas resulting from the flood hazard model (Figure 5.11 below).



Figure 5.11 Adaptation Areas towards Flood Risk in Tarakan City

Source: Water Sector Report, Setiawan et al, 2011

Area I located along north-east to south-east part of Tarakan City, which covers 5 major watersheds; i.e. Maya, Mangantai, Binalatung, Kuli, and Amal Baru. Current land use in the area are forests, shrubs, and agriculture area, thus based on RTRW Tarakan City 2011 – 2030 it was being assigned to become protected forest and city forest. As the current risk of inundation at the area is 3.3356 km<sup>2</sup>, in which it will increase to 4.8354 km<sup>2</sup> in year 2030. Therefore, there are two main strategies that being proposed; i.e. Integrated Water Resource Management (IWRM) and Restoration of River Function. IWRM in this context basically consists of planning activities of IWRM itself in which become baseline for further detailed IWRM activities; e.g. capturing society's views, reshaping planning processes, coordinating

land and water resources management, recognizing water quantity and quality linkages, conjunctive use of surface water and groundwater, protecting and restoring natural system, and including consideration of climate change. Restoration of river function, , will be implemented in accordance with Tarakan City’s Local Regulation Number 27 Year 2001.



Figure 5.12 Area I Land Use in 2008, Land Use in 2030, and Flood Risk in 2030  
Source: Water Sector Report, Setiawan, 2011

Area II covers 3 major watersheds; i.e. Semunti, Bengawan, and Persemaian. Current land use in the area are forests, shrubs, and agriculture area, thus based on RTRW Tarakan City 2011 – 2030 it was being assigned to become a new city center, remarks by new government offices. As the current risk of inundation at the area is 2.3576 km<sup>2</sup>, in which it will increase to 5.508 km<sup>2</sup> in year 2030. Therefore, there are two main strategies that being proposed; i.e. Integrated Water Resource Management (IWRM) and Restoration of River Function and Pond. The IWRM concept for this region can be developed altogether with IWRM mentioned in Area I. The pond restoration is aimed to provide two services; i.e. 1) to catch runoff water from higher elevation areas, and retain the runoff before releasing it into streams; 2) to preserve and become a supply for water resources. In addition it may also prevent or minimize flooding during high water periods, thus the location of the pond should be in a place which is surrounded by a spacious open area to accommodate probable spill over.

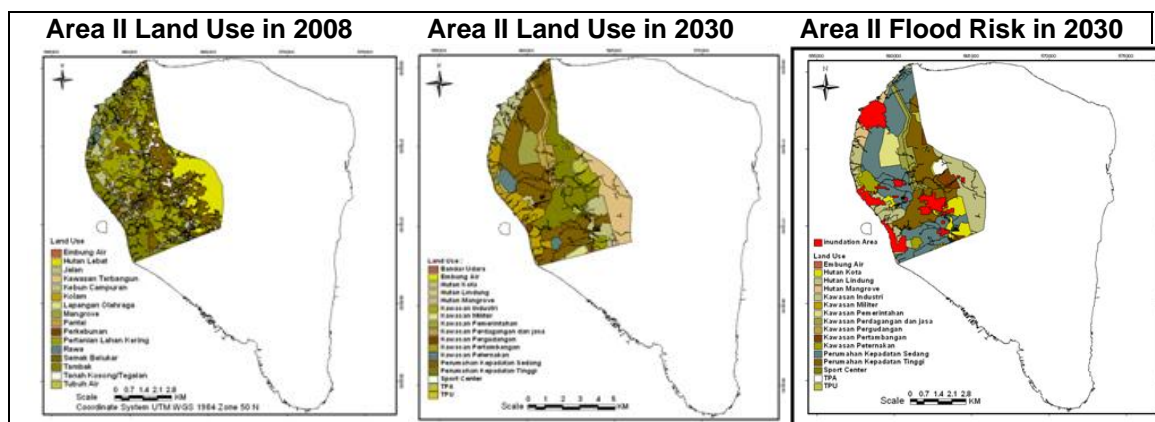

Figure 5.13 Area II Land Use in 2008, Land Use in 2030, and Flood Risk in 2030  
Source: Water Sector Report, Abdurahman et al, 2011



Area III covers 4 major watersheds; i.e. Sesanip, Kampung Bugis, Pamusian, and Karungan. Current conditions show that the location was basically already a built area; e.g. residential, business centre, trade, etc. Afterwards, based on the RTRW for Tarakan City 2011 – 2030 it will still be the city centre with several vital infrastructure components such as an airport, the military, industry, warehousing, etc. The current risk of inundation at the area is 3.365 km<sup>2</sup>, which will increase to 11.436 km<sup>2</sup> by 2030. Therefore, the adaptation strategy proposed is the installation of a sluice gate at the river, a levee, and pumping. Installation of the sluice gate may prevent tidal water, as its installation on the upstream is dedicated to avoid inundation in the downstream.

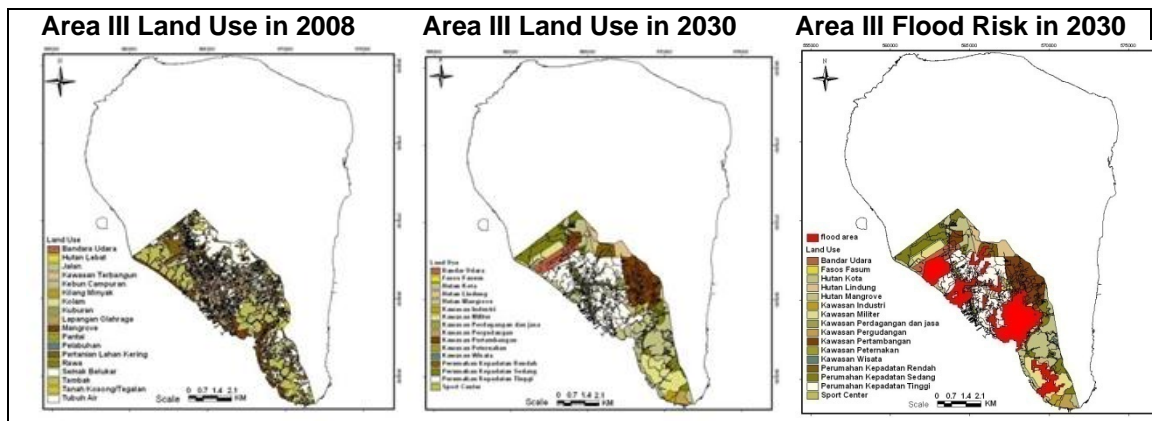

Figure 5.14 Area III Land Use in 2008, Land Use in 2030, and Flood Risk in 2030  
Source: Water Sector Report, Abdurrhahman et al, 2011

Table 5. 9 Recapitulation of Adaptation Strategies for Anticipating Flood Risk in Tarakan City

Adaptation Area	Land Use Type		Watershed	Hazard and Vulnerability Level	Risk Level	Adaptation Options
	Baseline	Projection				
Area I	Forest, Road, Residential, , Cropland, Pond, Mangrove, Beach, Agriculture land, Swamp, Stream	City Forest, Protected Forest, Utilities, Pond, Mangrove, Industrial area, Military Area, Commercial and Service Area, Warehouse Area, Fisheries Area, Mining Area, Tourism Area, Low-Moderate-High Dense Residential Area, Landfill, Sport Center, Cemetary	Maya Mangantai Binalatung Kuli Amal Baru	Hazard : No Inundation Inundation Area  Vulnerability : Low - High Vulnerability	Very Low Risk Low Risk Moderate Risk High Risk	Integrated Water Resources Management (IWRM) The Restoring of the river function
Area II	Pond, Forest, Road, Residential Cropland, Mangrove, Beach, Agriculture Land, Swamp, Shrubs, Stream	Pond, City Forest, Protected Forest, Mangrove, Industrial Area, Military Area, Government Area, Commercial and Service , Area, Warehouse Area, Mining Area, Farm Area, Moderate Density , Residential Area, High Density Residential Area, Sport Center, Landfill, Cemetary	Semunti Bengawan Persemaian	Hazard : No Inundation Inundation Area  Vulnerability : Low - High Vulnerability	Very Low Risk Low Risk Moderate Risk Very High Risk	Integrated Water Resources Management (IWRM) The Restoring of the river function and Retention Pond
Area III	Airport, Forest, Road, Residential, Cropland, Industrial Area, Pond, Cemetary, Mangrove, Beach, Port, Agriculture Land, Swamp, Shrubs, Stream	Airport, Utilities, City Forest, Protected Forest, Mangrove, Industrial Area Military Area, Commercial and Service Area, Warehouse Area, Mining Area, Farm Area, Tourism Area, Low-Moderate-High Density Residential Area, Sport Center	Sesanip Kampung Bugis Pamusian Karungan	Hazard : No Inundation Inundation Area  Vulnerability : Low - High Vulnerability	Very Low Risk Low Risk Moderate Risk High Risk Very High Risk	Installation of Sluice Gate at The River Levee Pumping

Source: Water Sector Report, Setiawan, 2011

### 5.4.2 Adaptation for Landslide

There are two approaches for adaptation to landslide risk in Tarakan City; i.e. forestation and protective or preventive engineering works. The distinguishing factor for each approach was based on the activities conducted or being planned on particular areas which having a risk of landslide. For instance, in high population areas with valuable assets, it is impossible to implement a rapid solution. The size and type of landslide, as well as its triggering mechanism, plays an important role in the determination of sensitivity to the climatic conditions and would require an integrated, protective or preventive engineering works based on type of landslide and the landslide size, as well as its mechanism, plays an important role in the determination of sensitivity to climatic conditions. Table 5.8 below shows the topology works for non-population and area with population.

Table 5. 10 Works Typology of Landslide Stabilization

Landslide Area	Stabilization	Physical Principle	Work Typology
Non-residential	Forestation	Reducing driving forces	Forestation and bioengineering
Residential	Engineering works	Reducing driving forces along failure surface	Scaling, splitting and removal of unstable rocks removal rocks, Slope regarding, Cut back, Toe weighting
		Shear stresses transfer Shear to elements founded	RETAINING STRUCTURES: Embedded walls, Gravity walls, Composite walls
			STRUCTURAL REINFORCEMENTS : Reinforced fills, Unstressed soil nails, Soil dowels, Reticulated micropiles, Lime nails/piles, Rock bolts and rock dowels
		Increase in total and Increase effective normal stresses acting along the failure surface	STRUCTURAL REINFORCEMENTS: Prestressed anchors, Prestressed soil nails
		Porous water pressure reduction	SURFACE PROTECTION AND DRAINAGE: Surface drainage channels, infilling tension cracks
			SUBSURFACE DRAINAGE: Trench drains, Drainage galleries, Cut-off drains, Vertical drains, Electro--osmosis
Increase in strength of Increase slope-forming material	STRENGTHNING: Chemical admixtures, Recompaction, Shear trenches, Grouting		

Source: Water Sector Report, Setiawan et al, 2011

The integrated implementation of landslide stabilization is needed to address the large scale impact of climate change from landslide, and the potential impact of climate change represents a major cause in the evolution of some landslides. We need detailed knowledge on geological, hydrogeology, and geomechanic conditions of sand parameters. Table 5.9 below shows integrated adaptation options to be implemented on landslide areas. Forestation is suitable to be implemented in Central Tarakan, where land use of the area is protected forest, city forest, and low density housing-with low and moderate level of risk. In addition, more knowledge of Tarakan Timur, where the land use area is city forest and medium density housing, is required to do a combination of forestation and engineering works.

The engineering works approach is appropriate for implementation in North Tarakan, where the land use is medium to high density housing, industrial, trading, and government area. As for West Tarakan, where the land use is high density housing and trading area; and some parts of Central Tarakan, where the land use is high density housing and mining area, are also suitable for the engineering works approach.

Table 5. 11 Adaptation Options in Landslide Area

Area	Subdistrict	Land Use Type		Hazard and Vulnerability Level	Risk Level	Adaptation Option
		Baseline	Projection			
1	Tarakan Utara	mangrove	medium density housing	very high	moderate	engineering works
		bushes	industrial			
		farming				
2	Tarakan Utara	field	trading area	very high	moderate	engineering works
		bushes	high density housing			
		dryland farming	medium density housing			
3	Tarakan Utara	farming	high density housing	very high	moderate	engineering works
		dryland farming	medium density housing			
		bushes	trading area			
		field	government area			
4	Tarakan Utara	dryland farming	trading area	very high	moderate	engineering works
		bushes				
5	Tarakan Barat	field	trading area	very high	moderate	engineering works
		bushes	high density housing			
		farming				
6	Tarakan Tengah	forest	protected forest	low	low	forestation
		bushes	city forest			
		field				
7	Tarakan Tengah	bushes	protected forest	very high	moderate	forestation
			low density housing			

Area	Subdistrict	Land Use Type		Hazard and Vulnerability Level	Risk Level	Adaptation Option
		Baseline	Projection			
8	Tarakan Barat	farming	high density housing	high	moderate	engineering works
		building region				
		field				
9	Tarakan Tengah	bushes	high density housing	high	low	engineering works
		farming				
10	Tarakan Tengah	bushes	mining area	high	low	engineering works
11	Tarakan Timur	forest	medium density housing	high	low	engineering works
		bushes				
		building region				
12	Tarakan Timur	building region	medium density housing	high	moderate	engineering works and forestation
			city forest			
13	Tarakan Timur	farming	city forest	low	low	engineering works and forestation
		field	medium density housing			
		bushes				

Source: Water Sector Report, 2010

### 5.4.3 Adaptation for Water Shortage

The adaptation concept to overcome the water shortage risk for Tarakan City has been developed by dividing the city into 6 zones (Figure 5.15). Those zones are being classified based on several factors; i.e. location, similarities in water resources (surface water and groundwater), current condition of the development, existing land use, and land use plan based on RTRW 2010 – 2030. The adaptation strategies proposed for each zone basically were developed based on the risk profile and groundwater potential. Therefore, it also enables for each zone to have sub-zones for addressing a more specific adaptation. As follows, here is the matrix summarizing the adaptation strategy for each zone.

Table 5. 12 Summary of Adaptation to Water Shortage

Zone	Description of Location and Water Provision	Consideration for Adaptation	Adaptation Strategy
Zone 1	<ul style="list-style-type: none"> <li>• Located in the current government and city center,</li> <li>• Consisting of 7 river basins,</li> <li>• Divided into Sub Zone 1A and 1B,</li> <li>• Water demand served by 3 IPA from PDAM (maximum capacity 10million m<sup>3</sup>/year ~ 305 lt/second)</li> </ul>	<ul style="list-style-type: none"> <li>• Water demand (in total): 10.9 million m<sup>3</sup>/year (350 lt/second) in 2010 and 27.3 million m<sup>3</sup>/year (870 lt/second) in 2030</li> <li>• Water demand (for Sub Zone 1A): 4,397,235 m<sup>3</sup>/year (0.14 m<sup>3</sup>/second) in 2010 and 6,552,654 m<sup>3</sup>/year (0.21 m<sup>3</sup>/second) in 2030.</li> <li>• Water demand (for Sub Zone 1B): will be experiencing large increase until 303% (from 6,788,195 m<sup>3</sup>/year in 2010 to 20,566,862 m<sup>3</sup>/year in 2030).</li> <li>• There's a reservoir with its capacity reach 200,000 m<sup>3</sup></li> </ul>	<ul style="list-style-type: none"> <li>• Optimization of water provision from PDAM for Sub Zone 1A.</li> <li>• For Sub Zone 1B, optimization of water provision from PDAM and utilisation of ground water</li> </ul>
Zone 2	<ul style="list-style-type: none"> <li>• Located surrounding the new government centre</li> <li>• Consists of 9 watersheds</li> <li>• Current water provision being supplied from IPA Juata Laut with discharge 30 lt/second</li> </ul>	<ul style="list-style-type: none"> <li>• Having 2 unutilized watersheds with large water potencies; i.e. Semunti (discharge 29.478m<sup>3</sup>/year) and Bengawan (discharge 29.478 m<sup>3</sup>/year)</li> <li>• The water demand will increase from the baseline situation; i.e. from 1,132 million m<sup>3</sup>/year (0.0359 m<sup>3</sup>/second) in 2010 to become 21,599 million m<sup>3</sup>/year (0.68 m<sup>3</sup>/second) in 2030</li> </ul>	<ul style="list-style-type: none"> <li>• Development of new IPAs, utilizing Semunti and Bengawan watersheds; i.e. having potency of discharge reaching 0.60 m<sup>3</sup>/second or 18,932 million m<sup>3</sup>/year.</li> <li>• Development of reservoir to complement two proposed new IPAs</li> <li>• Utilisation of groundwater from the aquifer layers which located at 13 m below the surface.</li> </ul>
Zone 3	<ul style="list-style-type: none"> <li>• Located in Juata Laut and Kampung Satu Skip Villages.</li> <li>• At the moment, the location is mostly an undeveloped area, however it will consist of settlement, industrial, and trading area based on the RTRW Tarakan.</li> <li>• Water for domestic usage mostly provided from local wells and springs.</li> </ul>	<ul style="list-style-type: none"> <li>• Water demand will increase from 0,127 m<sup>3</sup>/year to 24,840 m<sup>3</sup>/year.</li> <li>• Sub Zone 3A dominated by industrial, service and settlement; as 3B will be dominated by settlement and tourism. Thus, it affects the water demand by 2,21:1 for the 3A compared to 3B</li> </ul>	<ul style="list-style-type: none"> <li>• Utilisation of surface water.</li> <li>• Development of reservoir located in lower Mangantai River for Sub Zone 3A.</li> <li>• Development of reservoir for Sub Zone 3Bin watershed B.</li> </ul>

Zone	Description of Location and Water Provision	Consideration for Adaptation	Adaptation Strategy
	<ul style="list-style-type: none"> <li>Zone 3 will be divided into two Sub Sone; i.e. 3A and 3B</li> </ul>	<ul style="list-style-type: none"> <li>Surface water potency in 3A is smaller than 3B (1 : 1,63)</li> </ul>	
Zone 4	<ul style="list-style-type: none"> <li>Located in eastern of Tarakan</li> <li>The location was being planned to provide space for settlement, tourism, and educational area.</li> <li>The location was passed by small watersheds and Binalatung watershed as the largest one.</li> <li>Binalatung watershed was the source of IPA Kampung Skip which its discharge is 0,126 m<sup>3</sup>/second.</li> <li>Zone 4 is being divided into two Sub Zones; Sub Zone 4A and 4B.</li> </ul>	<ul style="list-style-type: none"> <li>The optimal discharge in the upstream of Binalatung is 0.5338 m<sup>3</sup>/second (16,835 m<sup>3</sup>/year); i.e. very large compared to the projected water demand (8,086 m<sup>3</sup>/year).</li> <li>Binalatung River located in the northern edge of Zone 4, stretching from north to south with length of 14 km; thus it will not be optimal for development of clean water infrastructure.</li> </ul>	<ul style="list-style-type: none"> <li>Optimization of IPA Binalatung for Sub Zone 4A</li> <li>Rainwater harvesting as well as other alternatives such as utilisation of shallow ground water and desalination, for Sub Zone 4B.</li> </ul>
Zone 5	<ul style="list-style-type: none"> <li>Located in the southern of Tarakan.</li> <li>At the moment the community whom reside at the location use springs to fulfill the water demand.</li> <li>Water demand 0,234million m<sup>3</sup>/year, mostly utilized by fish processing factory</li> </ul>	<ul style="list-style-type: none"> <li>Projected water demand 6,87 million m<sup>3</sup>/year.</li> <li>Minimum data to calculate groundwater potential, however survey showed that there's a potential of good quality of groundwater</li> </ul>	<ul style="list-style-type: none"> <li>Utilisation of ground water</li> <li>Other alternatives are sea water desalination and rainwater harvesting</li> </ul>
Zone 6	<ul style="list-style-type: none"> <li>Located at the heart of Tarakan City, dominated by protected forest area</li> </ul>	<ul style="list-style-type: none"> <li>The location is a recharge area for suppressed aquifers in West Tarakan</li> </ul>	<ul style="list-style-type: none"> <li></li> </ul>

Source: Summarized from Water Sector Report, Abdurahman et al, 2011

## **6. Risk Assessment Result and Adaptation Options in Health Sector**

### ***6.1 Results of Existing Hazard Analysis***

As a small island that is vulnerable to climate change, Tarakan has a high potential exposure to health hazards, such as temperature-related morbidity, deaths and injuries from extreme events, vector and rodent-borne diseases, water-borne diseases, ultraviolet induced diseases, mental and psychology impacts, allergenic diseases, air pollution induced diseases, malnutrition, and food poisoning. Regarding the top ten diseases in Tarakan, diarrhea is a water-borne disease that is strongly affected by change in climatic factors, such as drought, sea level rise, and rainfall pattern that distress water resources and sanitation (WHO, 2003). Moreover, many scientific evidences suggest that Dengue Hemorrhagic Fever (DHF) and malaria are top vector-borne diseases that are strongly affected by change in climate stimuli, such as temperature and rainfall.

Based on focus group discussions that were conducted, only vector-borne diseases (DHF and malaria) and water-borne disease (diarrhea) are discussed as health hazard in this study.

#### **6.1.1 Hazard Analysis of DHF**

Figure 6.1 presents the numbers of DHF cases, which are compared to the numbers of population in Tarakan.



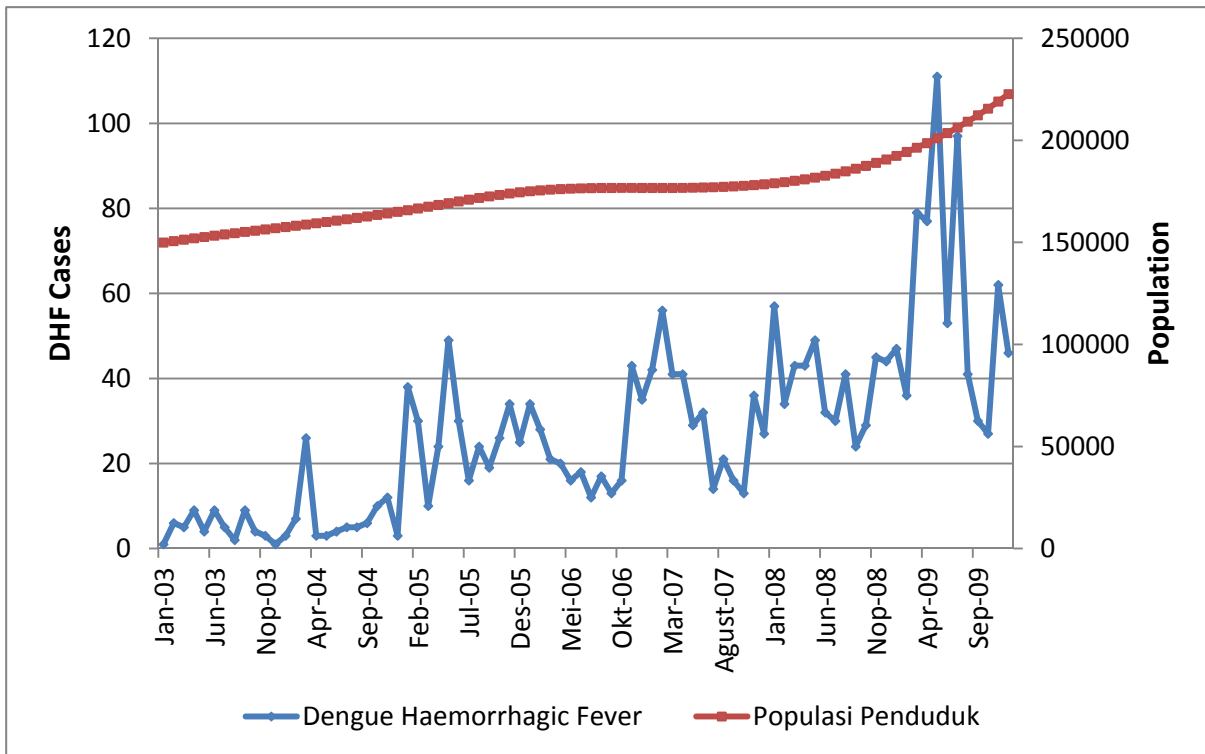

Figure 6.1 Monthly DHF Cases in Tarakan increase following the population

The trend of dengue fever cases in Tarakan and in each district of Tarakan increased from 2003 to 2009. However, whether the increases were mostly caused by climatic factors or other factors, such as population increase, the risk that these factors are not followed up by an improvement of sanitation and health facilities becomes the main problem addressed in this study.

In order to understand the correlation between DHF cases and population, Spearman's rank correlation is used, resulting with correlation coefficient between population and DHF cases in Tarakan is 0.784.

Meanwhile the association between monthly rainfall and monthly temperature to DHF cases in Tarakan is shown in Figure 6.2 and Figure 6.3.

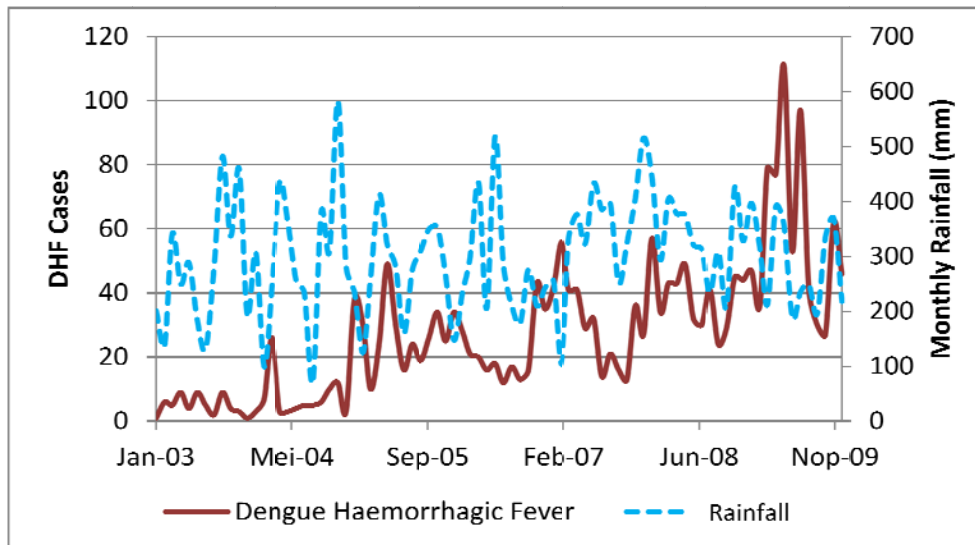

Figure 6. 2 Monthly DHF and Monthly Rainfall in Tarakan

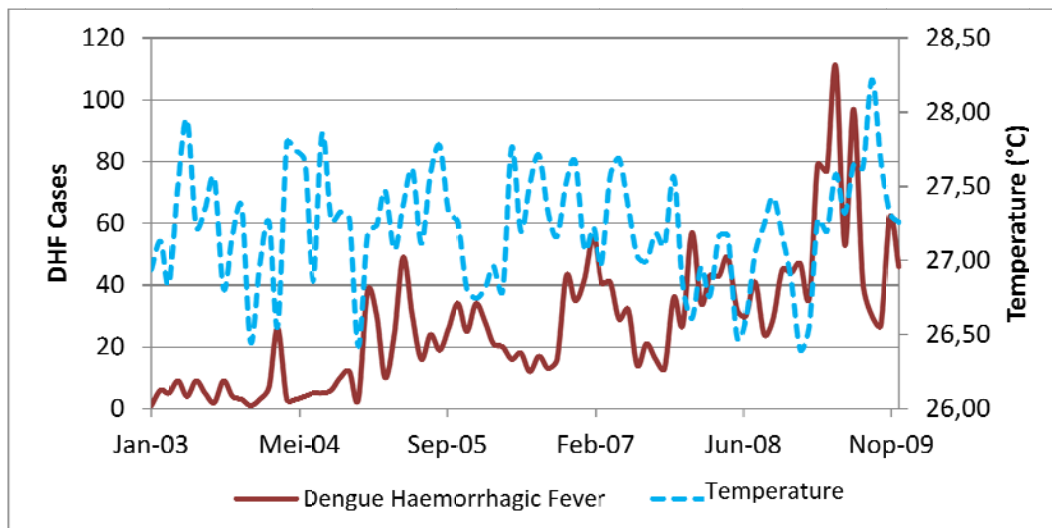

Figure 6. 3 Monthly DHF and Monthly Temperature in Tarakan

In order to see the association between precipitation (rainfall) and DHF cases, the monthly average of DHF and rainfall 2003-2009 have been calculated. In this way, the relationship between rainfall and DHF cases is shown in Figure below.

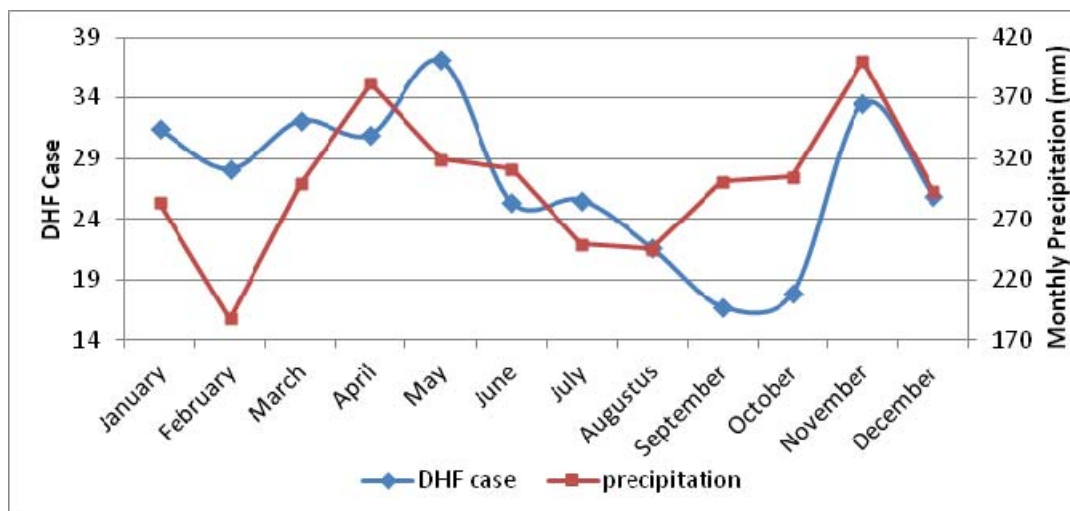

Figure 6. 4 Relationship between monthly rainfall with DHF Cases for average 2003-2009 in Tarakan

This figure indicates that the increase of rainfall in February-April is highly related to the increase of DHF cases in March-May which means that there is a 1 month lag between the increase of rainfall and DHF cases. Furthermore, the decrease of rainfall in May-August is followed by the decrease of DHF cases in June-September which means that there is 1 month lag between the decrease of rainfall and the decrease of DHF cases. The association with lag-0 and lag-1 is also shown in August-February. The increase of rainfall in September-November is related to the increase of DHF cases in October-November and the decrease of rainfall in December-February is related to the decrease of DHF cases in December-February.

The eight years average of prevalence (2003-2010) is used to categorise the hazard in village level as shown in table below.

Table 6.1 Existing Hazard Categorisation for DHF in Tarakan City

Subdistrict	Villages	Hazard (2003-2010)	
		Average Prevalence /10,000 Occupants	Level
Tarakan Timur	Lingkas Ujung	19.81	Moderate
	Gunung Lingkas	23.09	High
	Mamburungan	13.94	Low
	Mamburungan Timur	14.31	Low
	Kampung Empat	28.47	Very High
	Kampung Enam	20.67	High
	Pantai Amal	6.52	Very Low
Tarakan Tengah	Selumit Pantai	20.20	Moderate
	Selumit	23.76	Very High
	Sebengkok	19.91	Moderate
	Pamusian	17.91	Moderate
	Kampung Satu Skip	21.60	High
Tarakan Barat	Karang Rejo	17.08	Low
	Karang Balik	20.64	High
	Karang Anyar	24.85	Very High
	Karang Anyar Pantai	12.89	Very Low

Subdistrict	Villages	Hazard (2003-2010)	
		Average Prevalence /10,000 Occupants	Level
Tarakan Utara	Karang Harapan	13.52	Very Low
	Juata Permai	24.67	Very High
	Juata Kerikil	17.14	Low
	Juata Laut	11.75	Very Low

The figure below shows the hazard categorisation in spatial view. It is seen that most of Tarakan villages have a high level of DHF hazard, meaning that naturally this disease occurs in high prevalence. It is probably caused by the existence of the native inhabitant mosquitoes in large numbers.

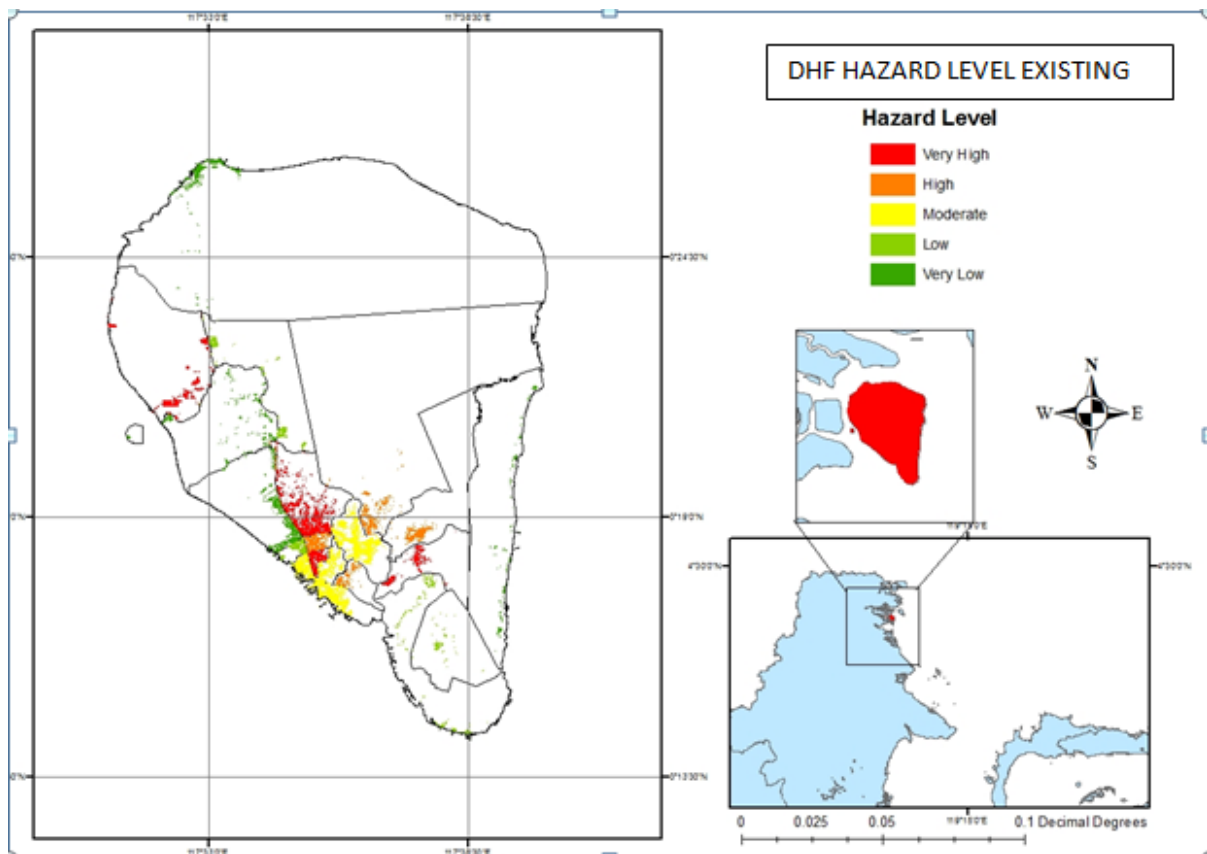

Figure 6. 5 Hazard Map of Existing DHF in Tarakan

A further process is building the models to determine the future hazard projection. To build a future prediction of disease occurrence, the Poisson regression and Compartment model of existing data was calculated.

The compartment models approaches the trend of disease occurrence by following the rainfall or temperature trends. However, the population number is influencing as well. Pictures below show the actual and estimated DHF occurrence by rainfall and temperature approach. It is seen that the estimated DHF more accurately follows the trend of actual disease in rainfall as a main factor. The error of estimation is higher in areas with higher number of DHF.

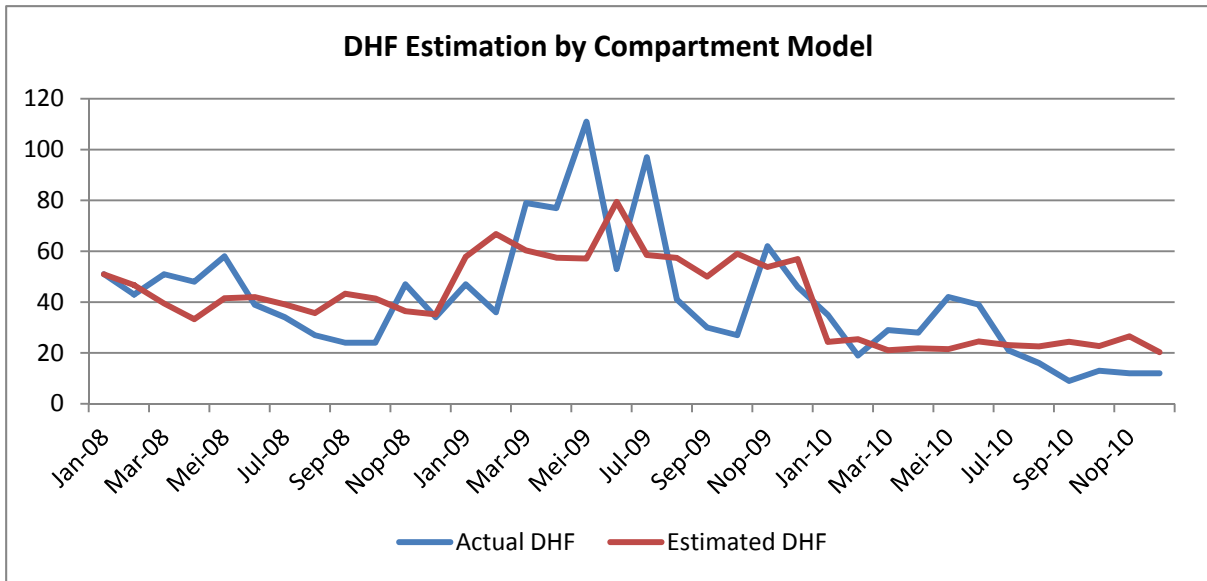

Figure 6. 6 DHF Estimation 2008-2010 in Tarakan City by Compartment Model

The final results from the compartment model are the Constant number ( $\mu$ ) and the coefficient number ( $b$ ). These two numbers are used in the equation to calculate the future hazard projection in the next section.

The Poisson regression uses the seven models and chooses the best fit model based on the least RMSE and AIC number. The figure below shows the estimation of DHF using Poisson regression in Tarakan City. This model produces the equation for future hazard projection. Since model 6 is the best model, the equation below is used to project the hazard by 2030. This step is shown in the next section. Figure 6.8 shows the DHF estimation using Poisson regression.

$$\ln(\mu_t) = -41,57 + 0.1371 \ln(\mu_{t-1}) + 0.3839 \ln(\mu_{t-2}) - 0.178T_t + 0.0001H_t + 3.96 \ln(Pop_t) + e_t$$

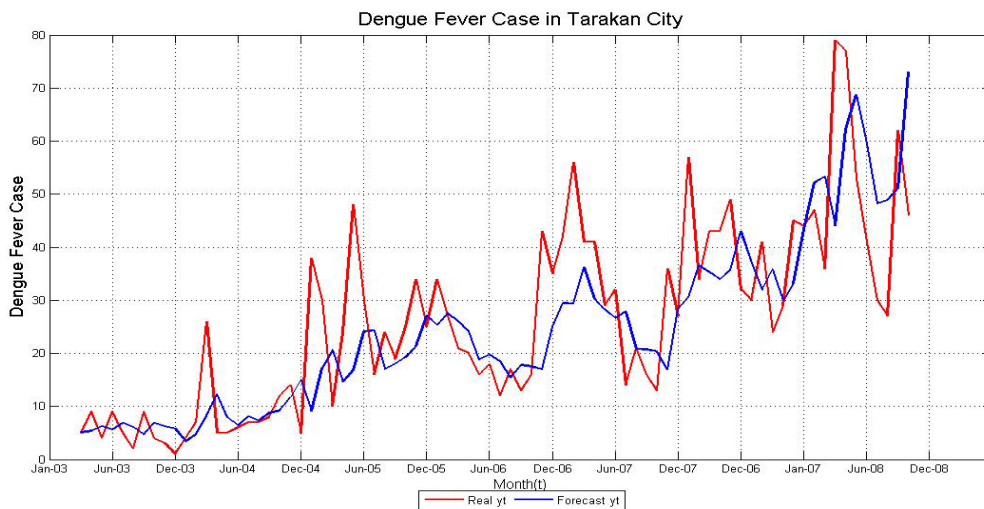

Figure 6. 7 DHF Estimation 2003-2008 in Tarakan City by Poisson Regression

### 6.1.2 Hazard Analysis of Diarrhea

There is not sufficient data available regarding monthly diarrhea cases in Tarakan city, so yearly ones were used for analysis as shown in the tables below.

Table 6.2: Diarrhea cases in Tarakan 2000-2010

No.	PHC	2000	2001	2002	2003	2004	2005	2006	2007	2008	2009	2010
1	Karang Rejo	796	840	861	1071	1101	843	1344	1176	1306	1304	2086
2	Gunung Lingkas	537	504	422	439	524	683	1027	711	913	1085	1336
3	Mamburungan	626	627	541	600	607	426	793	813	807	778	1057
4	Juata Laut	377	350	475	490	387	301	348	370	370	475	358
5	Juata Permai		184	234	415	692	770	907	671	1030	1084	1377
6	Pantai Amal		44	42	67	77	112	163	183	296	457	374
7	Sebengkok									254	785	391
Total			2549	2575	3082	3388	3135	4582	3924	4976	5968	6979

The eight years average of prevalence (2003-2010) is used to categorise the hazard at the village level as shown in table below. Figures 6.8 shows areas with different levels of diarrhea disease hazard.

Table 6. 3 Existing Hazard Categories of Diarrhea in Tarakan City

Sub-district	Villages	Average Prevalence (2003-2010) / 1,000 Occupants	Level (2003-2010)
Tarakan Timur	Lingkas Ujung	53.30	Very High
	Gunung Lingkas	53.30	Very High
	Mamburungan	17.00	Low
	Mamburungan Timur	17.00	Low
	Kampung Empat	16.52	Very Low
	Kampung Enam	16.52	Very Low
	Pantai Amal	16.52	Very Low
Tarakan Tengah	Selumit Pantai	13.63	Very Low
	Selumit	13.63	Very Low
	Sebengkok	13.63	Very Low
	Pamusian	17.00	Low
	Kampung Satu Skip	17.00	Low
Tarakan Barat	Karang Rejo	24.22	Moderate
	Karang Balik	24.22	Moderate
	Karang Anyar	24.22	Moderate
	Karang Anyar Pantai	24.22	Moderate
	Karang Harapan	50.60	Very High
Tarakan Utara	Juata Permai	50.60	Very High
	Juata Kerikil	50.60	Very High
	Juata Laut	40.70	High

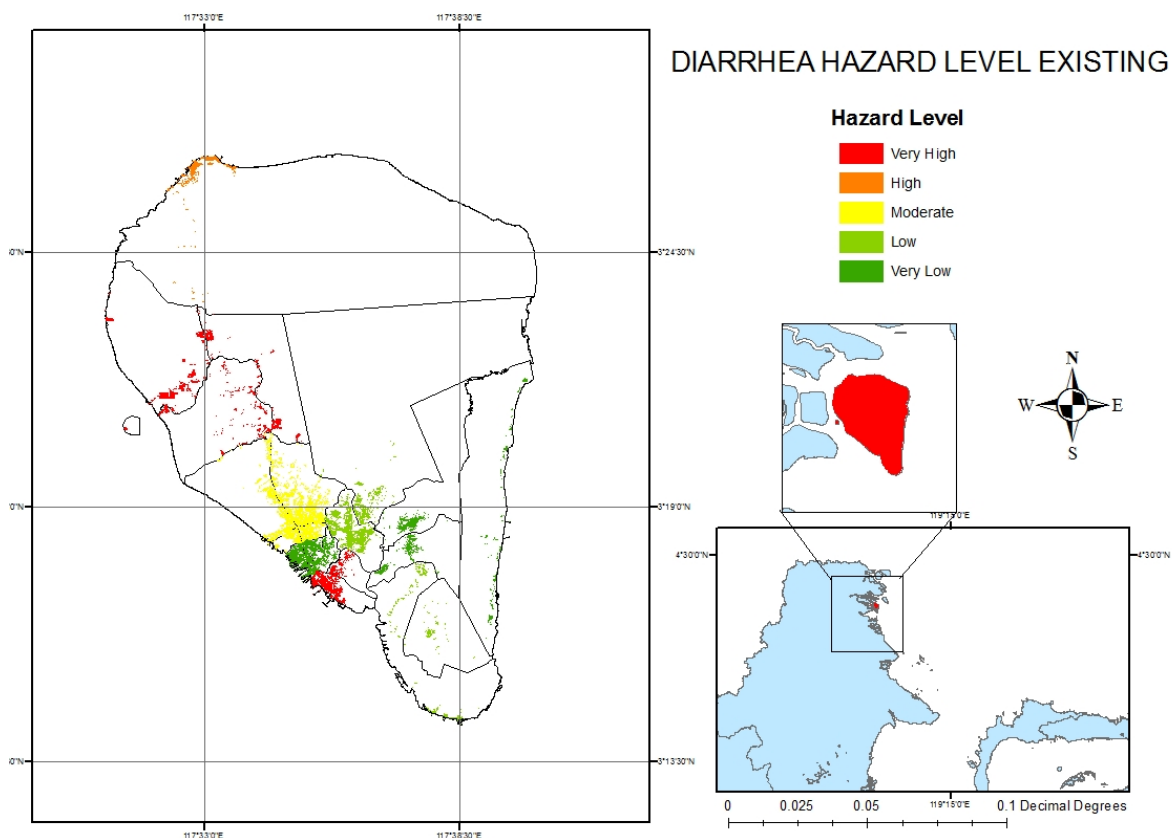

Figure 6. 8 Hazard Map of Existing Diarrhea in Tarakan

### 6.1.3 Hazard Analysis of Malaria

Data for monthly malaria cases were also not sufficiently available in Tarakan so we analyzed the yearly ones of 2007-2009 as shown in tables below.

Table 6.4 Malaria cases in Tarakan 2007-2009

No.	Primary Health Care	2007	2008	2009
1	Karang Rejo	0	0	0
2	Gunung Lingkas	2	3	2
3	Mamburungan	1	0	0
4	Juata Laut	1	0	1
5	Juata Permai	24	0	0
6	Pantai Amal	0	1	2
7	Sebengkok	0	0	0
Total		28	4	5

Table 6.5: Existing Hazard Categories of Malaria in Tarakan

Districts	Villages	Average Prevalence (2007-2009) /100,000 Occupants	Hazard Level (2007-2009)
Tarakan Timur	Lingkas Ujung	15.24	Very High
	Gunung Lingkas	15.24	Very High

Districts	Villages	Average Prevalence (2007-2009) /100,000 Occupants	Hazard Level (2007-2009)
	Mamburungan	0.52	Low
	Mamburungan Timur	0.52	Low
	Kampung Empat	12.30	Moderate
	Kampung Enam	12.30	Moderate
	Pantai Amal	12.30	Moderate
Tarakan Tengah	Selumit Pantai	0.00	Very Low
	Selumit	0.00	Very Low
	Sebengkok	0.00	Very Low
	Pamusian	0.52	Low
	Kampung Satu Skip	0.52	Low
Tarakan Barat	Karang Rejo	0.00	Very Low
	Karang Balik	0.00	Very Low
	Karang Anyar	0.00	Very Low
	Karang Anyar Pantai	0.00	Very Low
	Karang Harapan	44.44	Very High
Tarakan Utara	Juata Permai	44.44	Very High
	Juata Kerikil	44.44	Very High
	Juata Laut	6.93	High

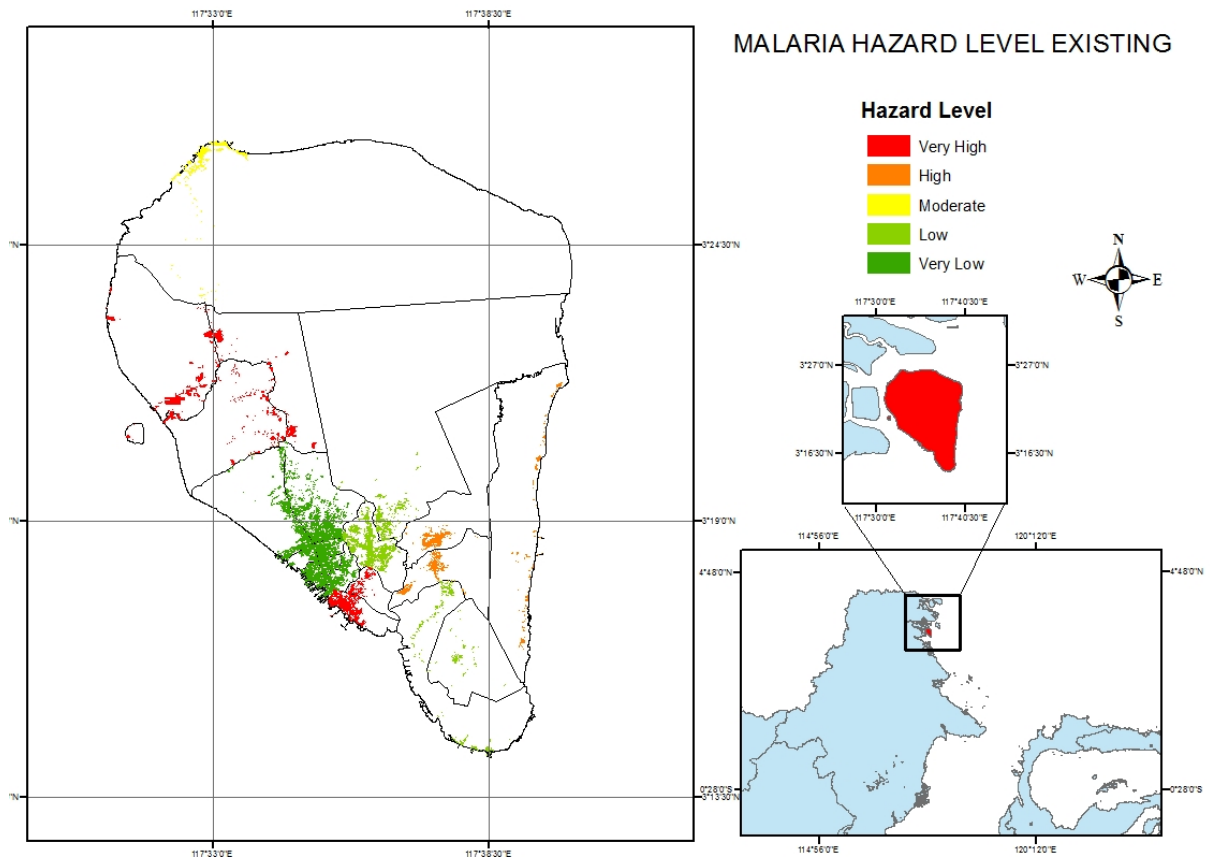

Figure 6. 9 Hazard Map of Existing Malaria in Tarakan



As shown, above figures, existing conditions of all disease hazards are more prominent in the western area of Tarakan.

## 6.2 Results of Projection Hazard Analysis for Year 2030

Projection of DHF, diarrhea and malaria for year 2030 were calculated by using deterministic model methods.

### 6.2.1 Results of DHF Hazard Projection in Tarakan 2011-2030

Projection of DHF in Tarakan city along year 2011-2030 was calculated by using a deterministic compartment model and its result is shown in the graph and tables below.

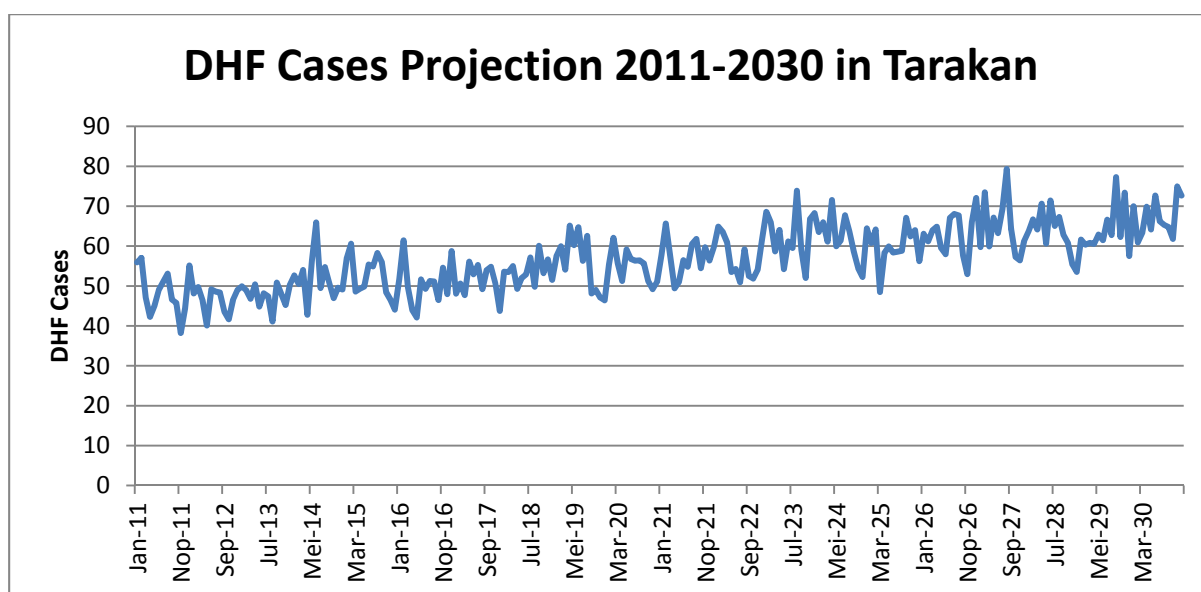

Figure 6. 10 Projection of DHF Cases 2011-2030 Based on Deterministic Model

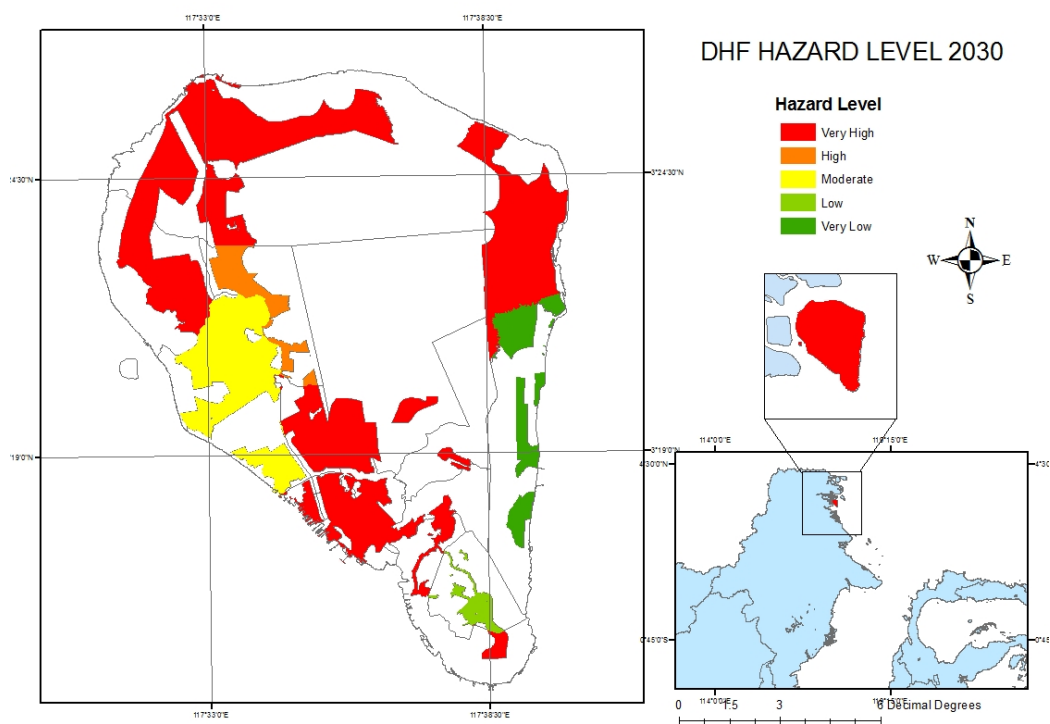

Figure 6. 11 Hazard Map of DHF Projection 2030

Table 6.6 Categories of DHF Hazard in 2030

Districts	Villages	Hazard	
		Prevalence (2030) /10,000 Occupants	Categories
Tarakan Timur	Lingkas Ujung	31.90	Very High
	Gunung Lingkas	38.33	Very High
	Mamburungan	27.48	Very High
	Mamburungan Timur	15.69	Low
	Kampung Empat	40.21	Very High
	Kampung Enam	25.03	Very High
	Pantai Amal	8.91	Very Low
Tarakan Tengah	Selumit Pantai	28.40	Very High
	Selumit	37.08	Very High
	Sebengkok	30.22	Very High
	Pamusian	28.23	Very High
	Kampung Satu Skip	38.92	Very High
Tarakan Barat	Karang Rejo	31.07	Very High
	Karang Balik	35.66	Very High
	Karang Anyar	42.11	Very High
	Karang Anyar Pantai	18.63	Moderate
	Karang Harapan	20.06	Moderate
Tarakan Utara	Juata Permai	32.79	Very High
	Juata Kerikil	22.56	High
	Juata Laut	24.41	Very High

In comparison to the existing DHF hazard data, the projected one with very high risk level would occur in almost all villages in Tarakan with the assumption of continuously population growth

### 6.2.2 Results of Diarrhea Hazard Projection in Tarakan 2011-2030

Projection of diarrhea in Tarakan city for year 2011-2030 was calculated by using a deterministic model and its result is shown in the graph and tables below.

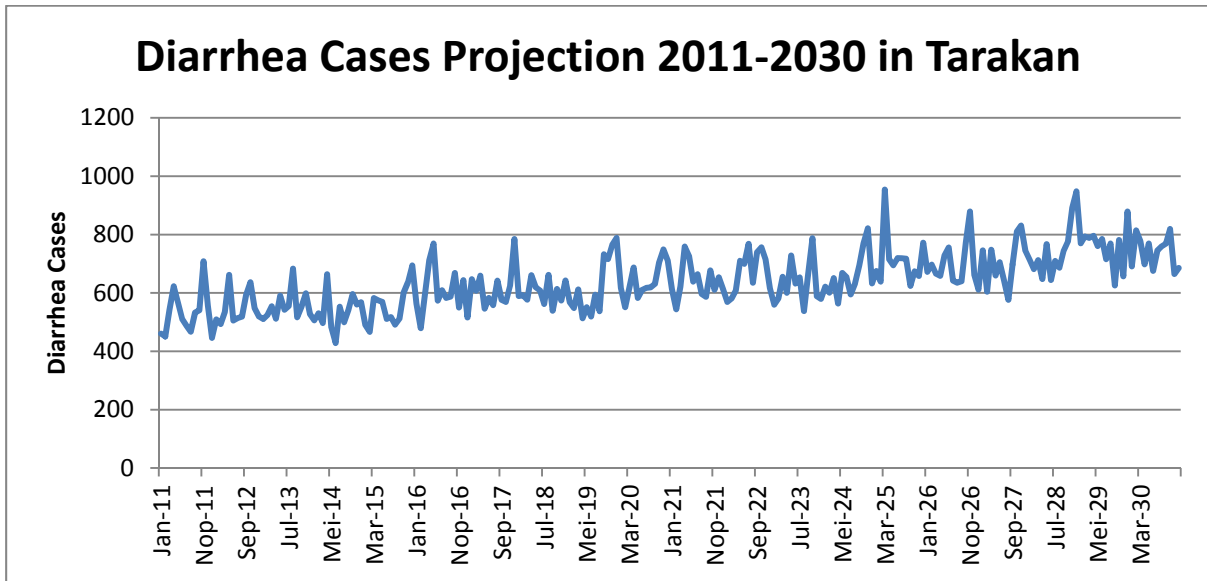

Figure 6. 12 Projection of Diarrhea Cases 2011-2030 Based on Deterministic Model

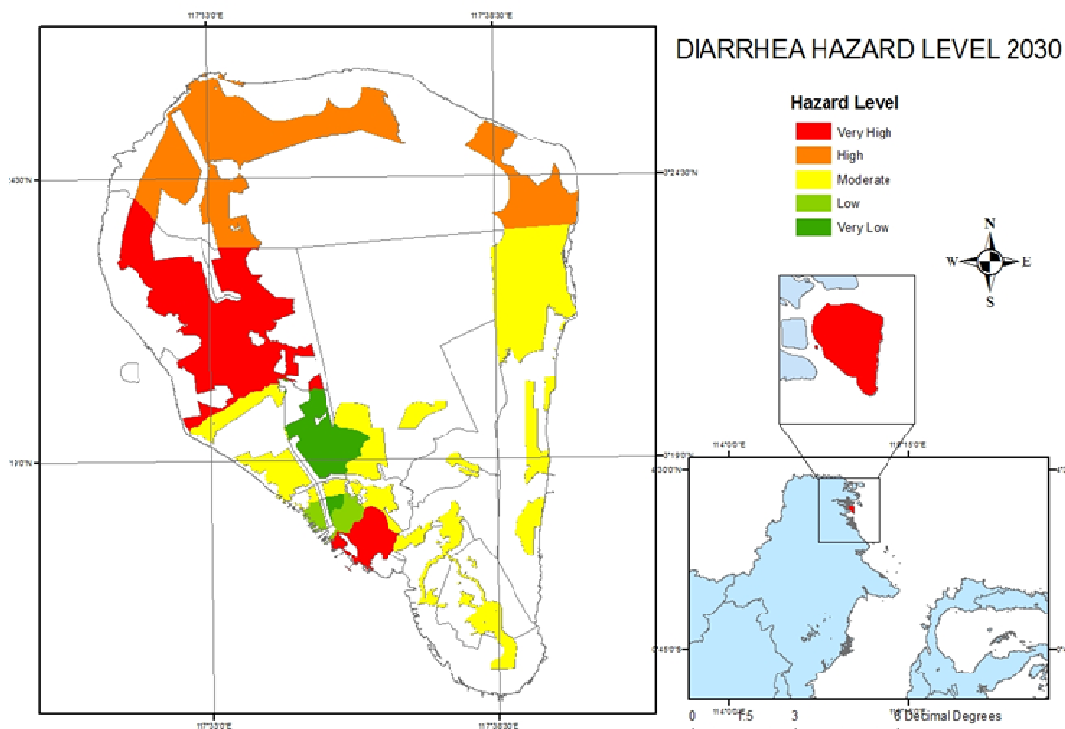

Figure 6. 13 Hazard Map of Diarrhea Cases Projection 2030

Table 6.7 Categories of Diarrhea Hazard in 2030

Districts	Villages	Hazard	
		Prevalence (2030)	Level
Tarakan Timur	Lingkas Ujung	60.54	Very High
	Gunung Lingkas	61.09	Very High
	Mamburungan	26.50	Moderate
	Mamburungan Timur	24.18	Moderate
	Kampung Empat	24.84	Moderate
	Kampung Enam	27.05	Moderate
	Pantai Amal	27.47	Moderate
Tarakan Tengah	Selumit Pantai	16.82	Low
	Selumit	14.56	Very Low
	Sebengkok	17.70	Low
	Pamusian	21.01	Moderate
	Kampung Satu Skip	32.97	Moderate
Tarakan Barat	Karang Rejo	30.32	Moderate
	Karang Balik	28.52	Moderate
	Karang Anyar	15.67	Very Low
	Karang Anyar Pantai	31.14	Moderate
	Karang Harapan	54.30	Very High
Tarakan Utara	Juata Permai	113.23	Very High
	Juata Kerikil	57.72	Very High
	Juata Laut	43.04	High

### 6.2.3 Results of Malaria Hazard Projection in Tarakan 2011-2030

Projection of malaria in Tarakan city for year 2011-2030 was calculated by using the compartment model and its result is shown in the graph and tables below.

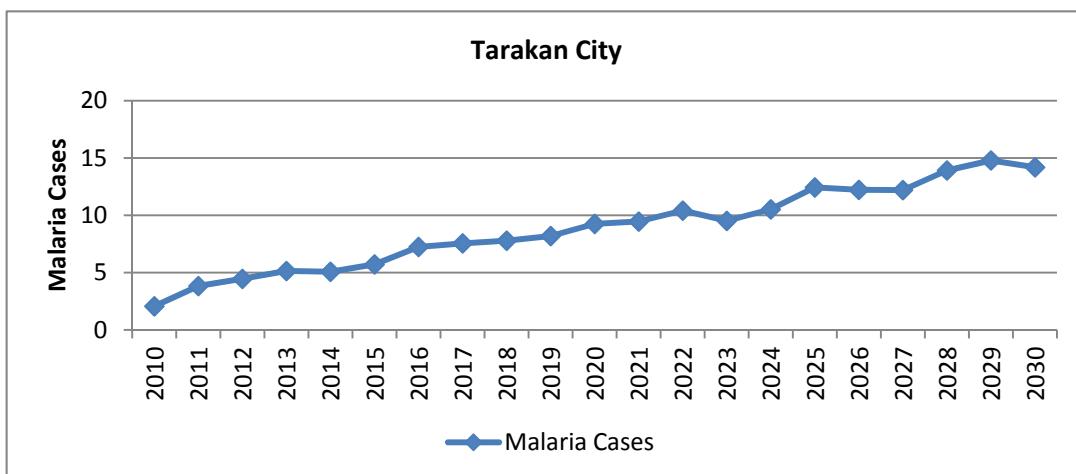

Figure 6. 14 Projection of Malaria Cases 2011-2030 Based on Compartment Model

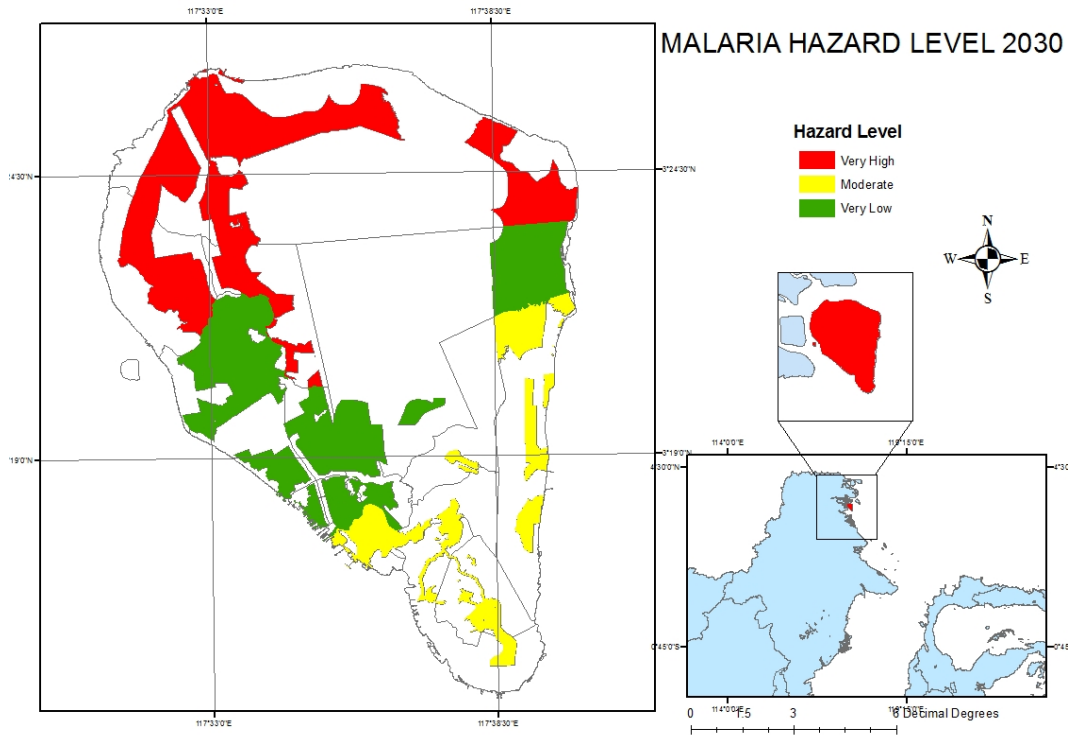

Figure 6. 15 Hazard Map of Malaria Cases Projection 2030

Table 6.8 Hazard Categories of Malaria in Tarakan City for 2030

Districts	Villages	Hazard	
		Prevalence (2030)	Hazard Level (2030)
Tarakan Timur	Lingkas Ujung	11.02	Moderate
	Gunung Lingkas	11.02	Moderate
	Mamburungan	11.02	Moderate
	Mamburungan Timur	11.02	Moderate
	Kampung Empat	11.02	Moderate
	Kampung Enam	11.02	Moderate
	Pantai Amal	11.02	Moderate
Tarakan Tengah	Selumit Pantai	0.00	Very Low
	Selumit	0.00	Very Low
	Sebengkok	0.00	Very Low
	Pamusian	0.00	Very Low
	Kampung Satu Skip	0.00	Very Low
Tarakan Barat	Karang Rejo	0.00	Very Low
	Karang Balik	0.00	Very Low
	Karang Anyar	0.00	Very Low
	Karang Anyar Pantai	0.00	Very Low
	Karang Harapan	0.00	Very Low
Tarakan Utara	Juata Permai	64.94	Very High
	Juata Kerikil	64.94	Very High
	Juata Laut	64.94	Very High

### 6.3 Results of Existing Vulnerability Analysis

#### 6.3.1 Vulnerability Assessment of DHF

Vulnerability of Tarakan City to DHF is categorised into three areas, i.e. its Exposure, Sensitivity and Adaptive Capacity. As seen in the figure below, the exposure to DHF is very high and high around Tarakan Tengah and Tarakan Utara Villages. Tarakan Tengah is where current population is concentrated (Selumit Pantai and Selumit), thus it is the most exposed to DHF. Meanwhile, for its sensitivity to DHF, the next figure shows that Tarakan Tengah is the most sensitive to DHF and this is due most likely to a low percentage of piped water coverage in that area. Piped water helps distribute the water directly in to the houses, therefore lowering the potential for inundation in the area, from infrastructure such as wells and reduces the use of water containers. As we know, a water container filled with fresh and clear water is suitable for the development of mosquito larvae. As for its adaptive capacity, we can see from the following figure that the adaptive capacity of Tarakan is ranging from very low to very high in most parts of the city; thus there is no distinctive pattern. In total, several villages in Tarakan Tengah and Tarakan Utara are highly vulnerable to DHF as we can see in Figure 6.16.

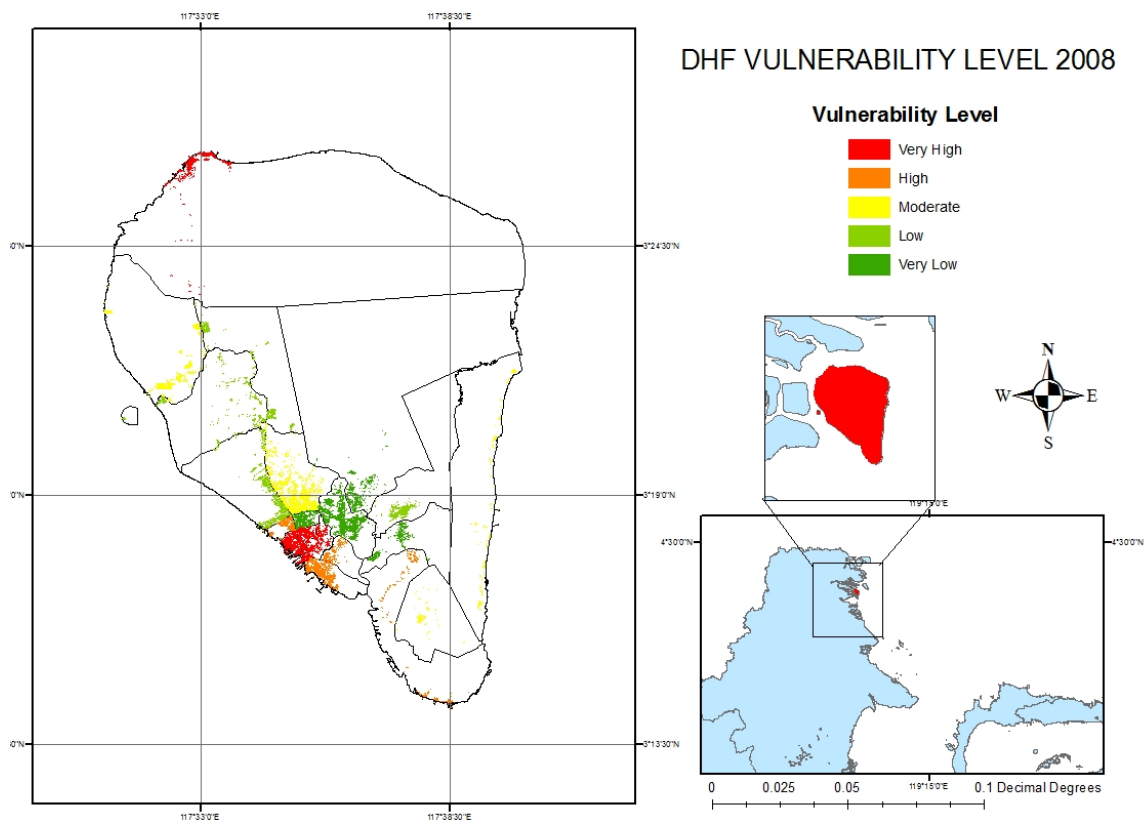

Figure 6.16 Vulnerability Map of Tarakan Subdistrict toward Existing DHF

Table 6. 9 Level of Existing Vulnerabilities to DHF in Tarakan City

Village	Vulnerability Level	Dominant Vulnerability Factors
Lingkas Ujung	High	High prevalence rate of DHF Low availability of Health Facility
Gunung Lingkas	High	High prevalence rate of DHF High population density
Mamburungan	High	Low piped water coverage
Mamburungan Timur	Moderate	High prevalence rate of DHF Low piped water coverage
Kampung Empat	Very Low	High prevalence rate of DHF Low availability of Health Facility
Kampung Enam	Low	High prevalence rate of DHF Low availability of health facility
Pantai Amal	Moderate	Low piped water coverage
Selumit Pantai	Very High	High prevalence rate of DHF High population density Low availability of health facility
Selumit	Very High	High prevalence rate of DHF High population density
Sebengkok	Very High	High prevalence rate of DHF High population density Low availability of Health Facility
Pamusian	Very Low	High prevalence rate of DHF
Kampung Satu Skip	Very Low	High prevalence rate of DHF
Karang Rejo	High	High population density
Karang Balik	Very Low	High prevalence rate of DHF
Karang Anyar	Moderate	High prevalence rate of DHF Low availability of health facility
Karang Anyar Pantai	Low	
Karang Harapan	Low	
Juata Permai	Moderate	High prevalence rate of DHF Low piped water coverage
Juata Kerikil	Low	Low piped water coverage
Juata Laut	Very High	Low availability of health facility

### 6.3.2 Vulnerability Assessment of Malaria and Diarrhea

The result of the vulnerability assessment for malaria, as illustrated in figure below, shows that Juata Laut also becomes the most vulnerable village to Malaria. On the other hand, the west and south regions of Tarakan have moderate vulnerability to malaria.

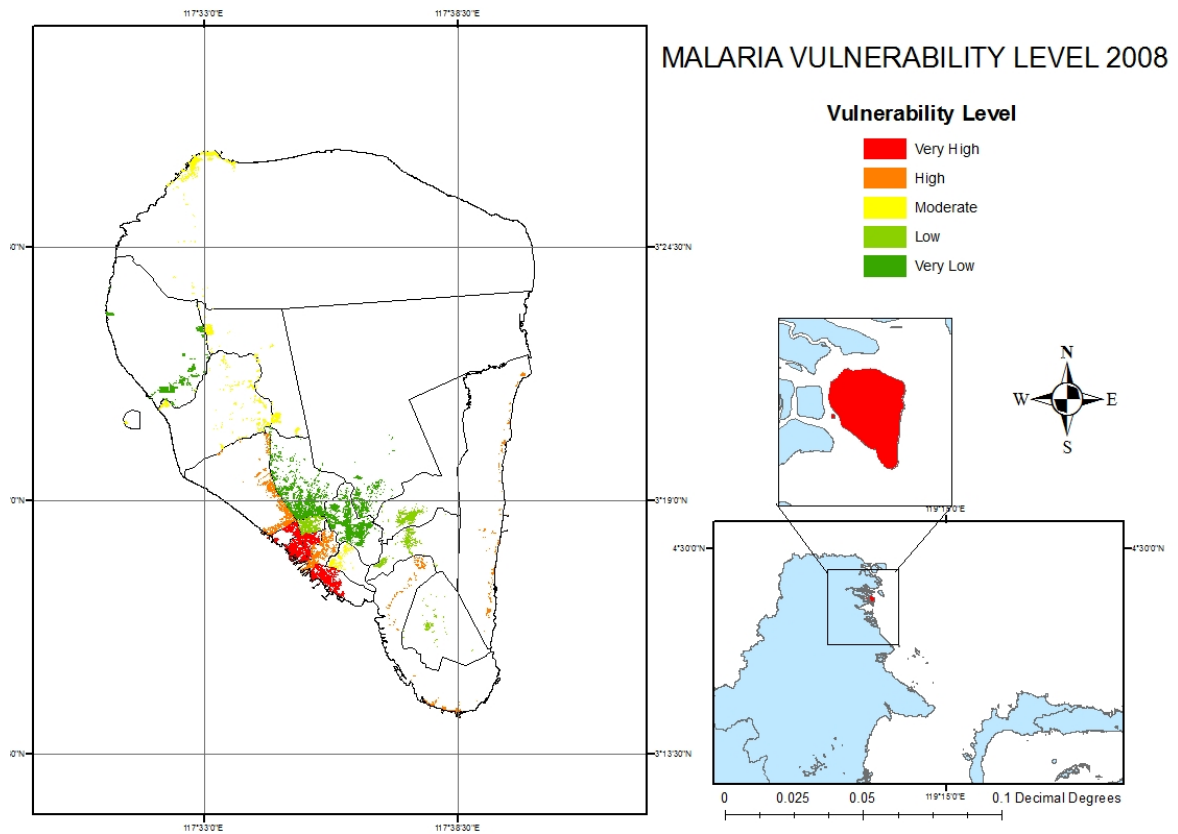

Figure 6. 17 Vulnerability Map of Tarakan Subdistrict toward Existing Malaria

Meanwhile, in the vulnerability assessment for diarrhea, Juata Laut shares the same highest vulnerability toward malaria, DHF, and diarrhea and is followed by west Tarakan region with moderate vulnerability. While the east region elicits low vulnerability to diarrhea.



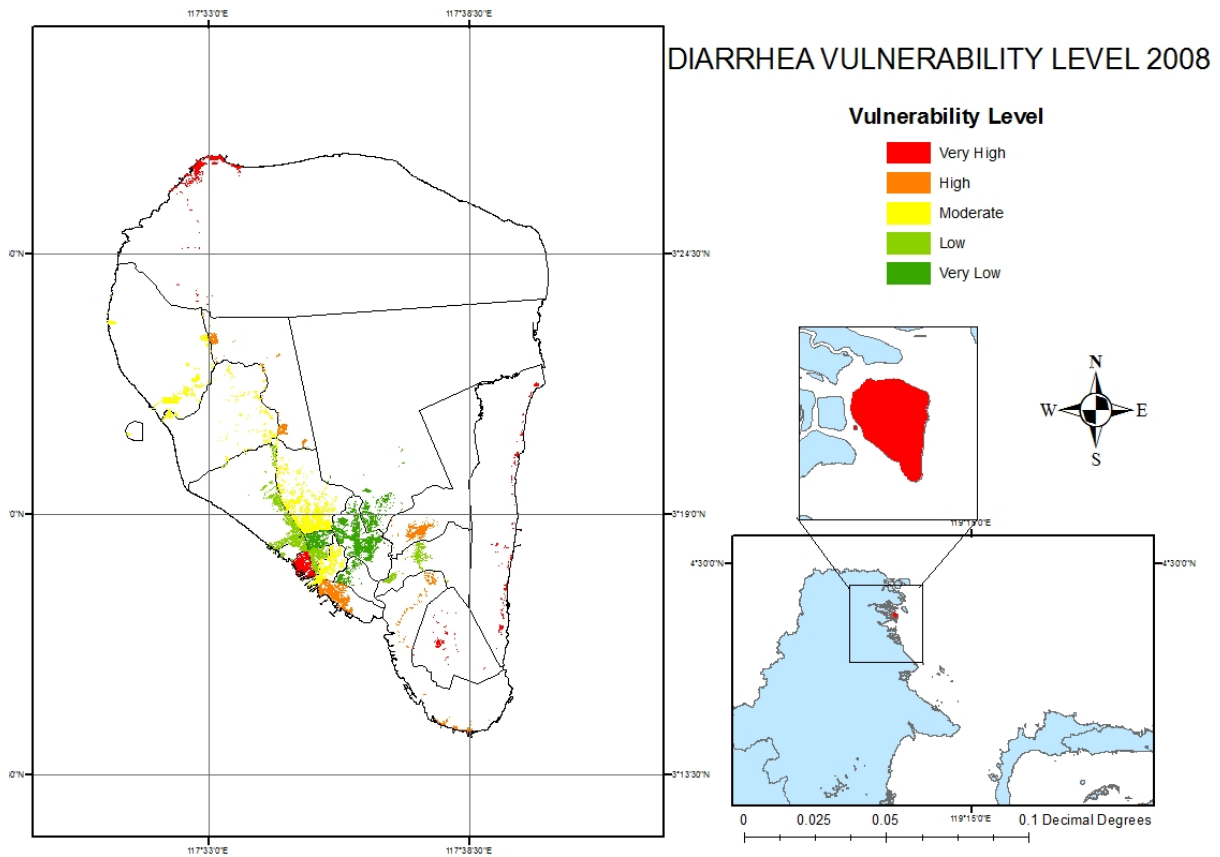

Figure 6. 18 Vulnerability Map of Tarakan Subdistrict to Existing Diarrhea

Finally, the vulnerability score of all villages in Tarakan is illustrated in the table below.

Table 6. 10 Vulnerability Scores for Existing DHF, Malaria and Diarrhea in Tarakan

Villages	DHF	Malaria	Diarrhea
Lingkas Ujung	High	Very High	High
Gunung Lingkas	High	Moderate	Very Low
Mamburungan	High	High	High
Mamburungan Timur	Moderate	Low	Very High
Kampung Empat	Very Low	Low	Low
Kampung Enam	Low	Low	High
Pantai Amal	Moderate	High	Very High
Selumit Pantai	Very High	Very High	Very High
Selumit	Very High	Very High	Low
Sebengkok	Very High	High	Moderate
Pamusian	Very Low	Very Low	Very Low
Kampung Satu Skip	Very Low	Very Low	Very Low
Karang Rejo	High	Very High	Low
Karang Balik	Very Low	Low	Very Low
Karang Anyar	Moderate	Very Low	Moderate
Karang Anyar Pantai	Low	High	Low

Villages	DHF	Malaria	Diarrhea
Karang Harapan	Low	Moderate	Moderate
Juata Permai	Moderate	Very Low	Moderate
Juata Kerikil	Low	Moderate	High
Juata Laut	Very High	Moderate	Very High

#### 6.4 Results of Projection Vulnerability Analysis for 2030

The vulnerability analysis for 2030 is conducted similarly as the existing vulnerability analysis. It needs various data from the General Spatial Plan (RTRW) for 2030 or programs target in health and environment sectors.

##### 6.4.1 Results of DHF Vulnerability Analysis for 2030

The result of projection vulnerability analysis of DHF in 2030 is presented in the table and figure below.

Table 6. 11 Vulnerability Score for Future DHF in Tarakan (Year 2030)

District	Villages	Vulnerability	Level
Tarakan Timur	Lingkas Ujung	0.38	Very High
	Gunung Lingkas	0.15	Very Low
	Mamburungan	0.16	Very Low
	Mamburungan Timur	0.17	Very Low
	Kampung Empat	0.16	Very Low
	Kampung Enam	0.13	Very Low
	Pantai Amal	0.03	Very Low
Tarakan Tengah	Selumit Pantai	0.42	Very High
	Selumit	0.27	High
	Sebengkok	0.38	Very High
	Pamusian	0.17	Very Low
	Kampung Satu Skip	0.13	Very Low
Tarakan Barat	Karang Rejo	0.35	Very High
	Karang Balik	0.33	Very High
	Karang Anyar	0.16	Very Low
	Karang Anyar Pantai	0.27	High
	Karang Harapan	0.09	Very Low
Tarakan Utara	Juata Permai	0.21	Moderate
	Juata Kerikil	0.10	Very Low
	Juata Laut	0.28	High

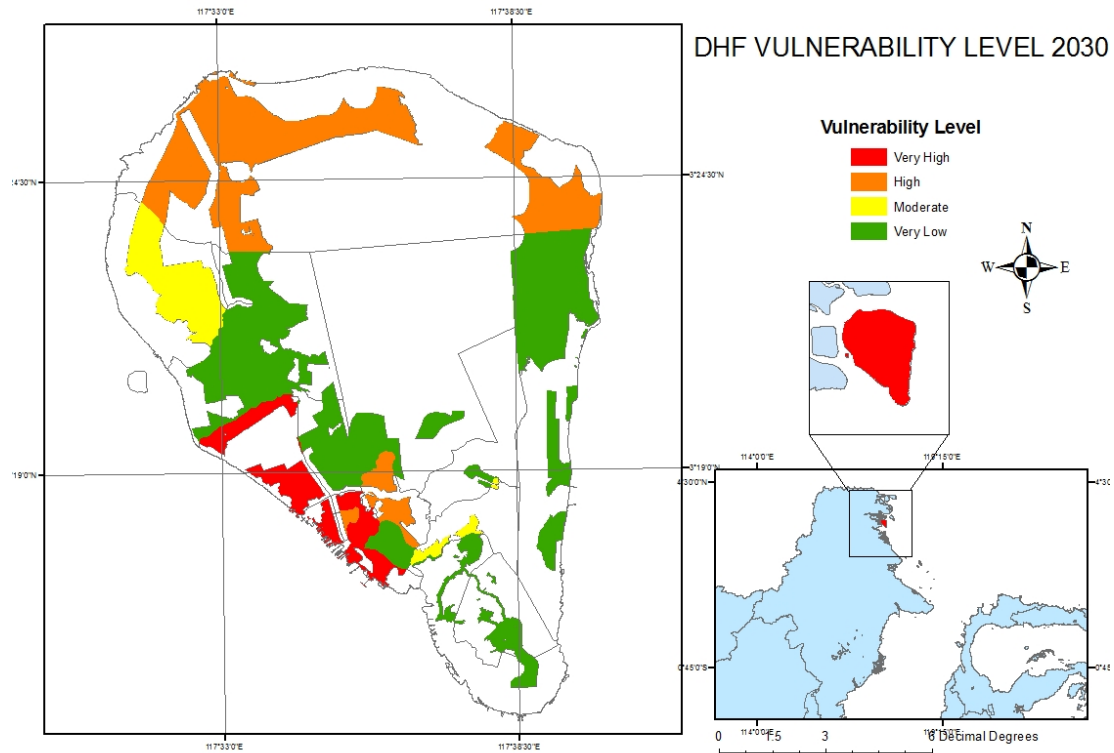

Figure 6. 19 Vulnerability Map of Tarakan tSubdistrict toward DHF Year 2030

#### 6.4.2 Results of Malaria Vulnerability Analysis for 2030

The result of projection vulnerability analysis of Malaria in 2030 is presented in the table and figure below.

Table 6. 12 Vulnerability Scores for Future Malaria in Tarakan (Year 2030)

District	Subdistrict	Vulnerability	Level
Tarakan Timur	Lingkas Ujung	0.05	Very Low
	Gunung Lingkas	0.08	Very Low
	Mamburungan	0.08	Very Low
	Mamburungan Timur	0.09	Very Low
	Kampung Empat	0.21	Low
	Kampung Enam	0.42	Moderate
	Pantai Amal	0.44	Moderate
Tarakan Tengah	Selumit Pantai	0.50	Moderate
	Selumit	0.24	Low
	Sebengkok	0.35	Moderate
	Pamusian	0.48	Moderate
	Kampung Satu Skip	0.18	Very Low
Tarakan Barat	Karang Rejo	0.78	Very High
	Karang Balik	0.77	Very High
	Karang Anyar	0.29	Moderate
	Karang Anyar Pantai	0.38	Moderate
	Karang Harapan	0.17	Very Low

Tarakan Utara	Juata Permai	0.24	Low
	Juata Kerikil	0.34	Moderate
	Juata Laut	0.16	Very Low

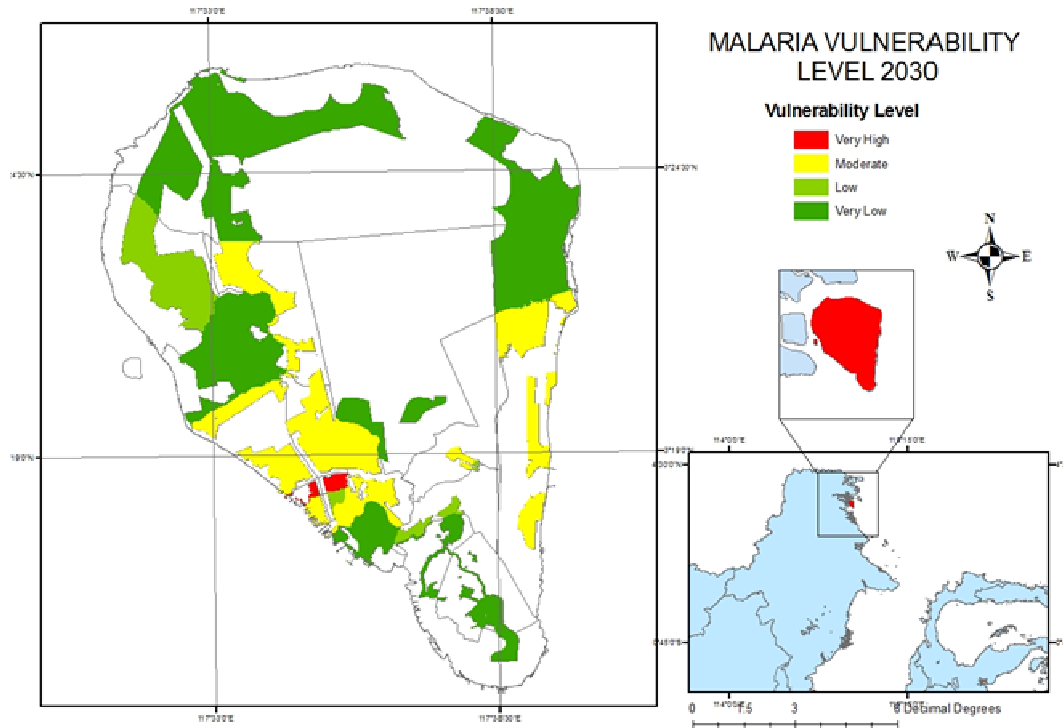

Figure 6. 20 Vulnerability Map of Tarakan tSubdistrict toward Malaria Year 2030

### 6.4.3 Results of Diarrhea Vulnerability Analysis for 2030

The result of projection vulnerability analysis of Diarrhea in 2030 is presented in the table and figure below.

Table 6. 13 Vulnerability Scores for Future Diarrhea in Tarakan (Year 2030)

District	Subdistrict	Vulnerability	Level
Tarakan Timur	Lingkas Ujung	0.37	High
	Gunung Lingkas	0.29	High
	Mamburungan	0.34	High
	Mamburungan Timur	0.41	Very High
	Kampung Empat	0.30	High
	Kampung Enam	0.23	Low
	Pantai Amal	0.18	Very Low
Tarakan Tengah	Selumit Pantai	0.40	Very High
	Selumit	0.20	Low
	Sebengkok	0.33	High
	Pamusian	0.29	High
	Kampung Satu Skip	0.25	Moderate
Tarakan	Karang Rejo	0.33	High

District	Subdistrict	Vulnerability	Level
Barat	Karang Balik	0.28	High
	Karang Anyar	0.20	Low
	Karang Anyar Pantai	0.46	Very High
	Karang Harapan	0.24	Low
Tarakan Utara	Juata Permai	0.26	Moderate
	Juata Kerikil	0.20	Low
	Juata Laut	0.44	Very High

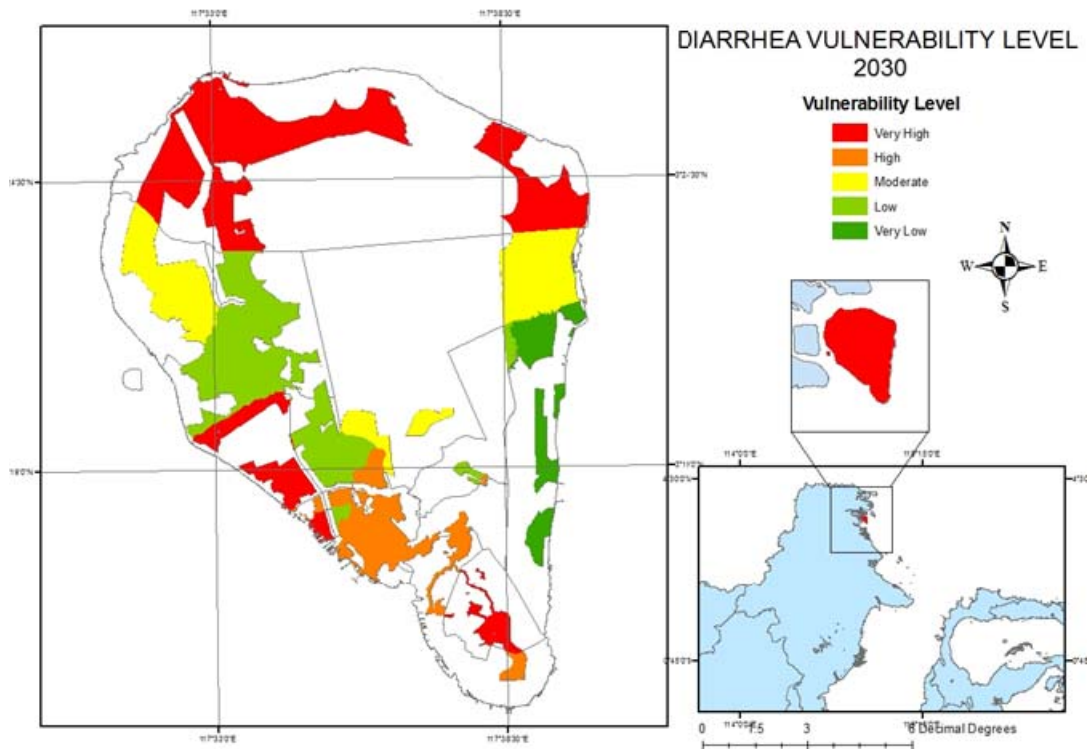

Figure 6. 21 Vulnerability Map of Tarakan Subdistrict toward Diarrhea Year 2030

## 6.5 Results of Existing Risk Analysis

### 6.5.1 Results of DHF Risk Analysis

The characteristics of each village in Tarakan according to its hazard, vulnerability and risk toward DHF are outlined in Table 6.14 and illustrated in Figure 6.22 below. This analysis shows that a very high risk of DHF occurred in Selumit, while Karang Anyar Pantai and Karang Harapan a elicit very low risk of DHF.

Table 6. 14 Existing Hazard, Vulnerability and Risk to DHF in Tarakan City

Subdistrict	Villages	Hazard		Vulnerability		Risk
		Average prevalence 2003-2010 /10,000 Occupants	Categories	Score	Categories	
Tarakan Timur	Lingkas Ujung	19.81	Moderate	0.25	High	High
	Gunung Lingkas	23.09	High	0.31	High	High
	Mamburungan	13.94	Low	0.25	High	Moderate
	Mamburungan Timur	14.31	Low	0.23	Moderate	Low
	Kampung Empat	28.47	Very High	0.15	Very Low	Moderate
	Kampung Enam	20.67	High	0.20	Low	Moderate
	Pantai Amal	6.52	Very Low	0.22	Moderate	Low
Tarakan Tengah	Selumit Pantai	20.20	Moderate	0.40	Very High	High
	Selumit	23.76	Very High	0.32	Very High	Very High
	Sebengkok	19.91	Moderate	0.36	Very High	High
	Pamusian	17.91	Moderate	0.15	Very Low	Low
	Kampung Satu Skip	21.60	High	0.07	Very Low	Low
Tarakan Barat	Karang Rejo	17.08	Low	0.26	High	Moderate
	Karang Balik	20.64	High	0.10	Very Low	Low
	Karang Anyar	24.85	Very High	0.23	Moderate	High
	Karang Anyar Pantai	12.89	Very Low	0.20	Low	Very Low
	Karang Harapan	13.52	Very Low	0.21	Low	Very Low
Tarakan Utara	Juata Permai	24.67	Very High	0.23	Moderate	High
	Juata Kerikil	17.14	Low	0.20	Low	Low
	Juata Laut	11.75	Very Low	0.40	Very High	Moderate

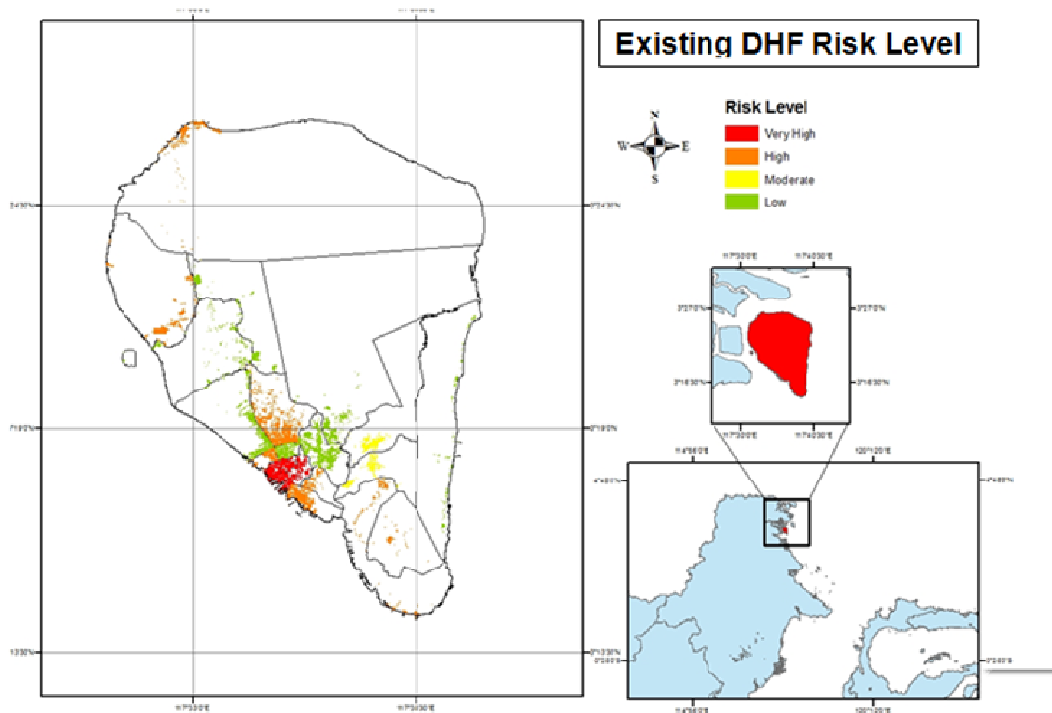

Figure 6. 22 Risk Map of Existing DHF in Tarakan

Table 6.15 mentions the major factors influencing the very high risk score of DHF in the villages of Tarakan. In general, the very high risk of DHF in the north area of Tarakan is more caused by low piped water coverage and total population, while in the middle area it is caused by population density. Moreover, all the very high risk areas have high annual prevalence rate of DHF

Table 6. 15 Factors Influence the Risk Score 2008 in tSubdistricts with Very High Risk Score of DHF

Villages with High Risk of DHF	Component	Main Causal Factors
<b>Tarakan Tengah</b>		
Selumit Pantai	Hazard	High prevalence rate of DHF
	Vulnerability	High population density
		Low availability of health facility
Selumit	Hazard	High prevalence rate of DHF
	Vulnerability	High population density
Sebengkok	Hazard	High prevalence rate of DHF
	Vulnerability	High population density
		Low piped water coverage
<b>Tarakan Utara</b>		
Juata Permai	Hazard	High prevalence rate of DHF
	Vulnerability	Low piped water coverage
<b>Tarakan Timur</b>		
Lingkas Ujung	Vulnerability	High population density
		Low availability of health facility
Gunung Lingkas	Hazard	High prevalence rate of DHF
	Vulnerability	High population density

Villages with High Risk of DHF	Component	Main Causal Factors
<b>Tarakan Barat</b>		
Karang Anyar	Hazard	High prevalence rate of DHF

### 6.5.2 Results of Diarrhea Risk Analysis

Risk of diarrhea in corresponding districts is determined according to the Risk Assessment Matrix. The results in tabular form are shown in Table 6.16, while the Risk Map is shown in Figure 6.23.

Table 6. 16 Existing Hazard, Vulnerability and Risk to Diarrhea in Tarakan

Subdistrict	Villages	Hazard		Vulnerability		Risk
		Prevalence (2030) /1,000 Occupants	Level	Score	Level	
Tarakan Timur	Lingkas Ujung	53.30	Very High	0.33	High	Very High
	Gunung Lingkas	53.30	Very High	0.18	Very Low	Moderate
	Mamburungan	17.00	Low	0.38	High	Moderate
	Mamburungan Timur	17.00	Low	0.42	Very High	High
	Kampung Empat	16.52	Very Low	0.20	Low	Very Low
	Kampung Enam	16.52	Very Low	0.29	High	Low
	Pantai Amal	16.52	Very Low	0.38	Very High	Moderate
Tarakan Tengah	Selumit Pantai	13.63	Very Low	0.41	Very High	Moderate
	Selumit	13.63	Very Low	0.21	Low	Very Low
	Sebengkok	13.63	Very Low	0.25	Moderate	Low
	Pamusian	17.00	Low	0.17	Very Low	Very Low
	Kampung Satu Skip	17.00	Low	0.09	Very Low	Very Low
Tarakan Barat	Karang Rejo	24.22	Moderate	0.18	Low	Low
	Karang Balik	24.22	Moderate	0.15	Very Low	Low
	Karang Anyar	24.22	Moderate	0.25	Moderate	Moderate
	Karang Anyar Pantai	24.22	Moderate	0.24	Low	Low
	Karang Harapan	50.60	Very High	0.26	Moderate	High
Tarakan Utara	Juata Permai	50.60	Very High	0.28	Moderate	High
	Juata Kerikil	50.60	Very High	0.28	High	Very High
	Juata Laut	40.70	High	0.48	Very High	Very High



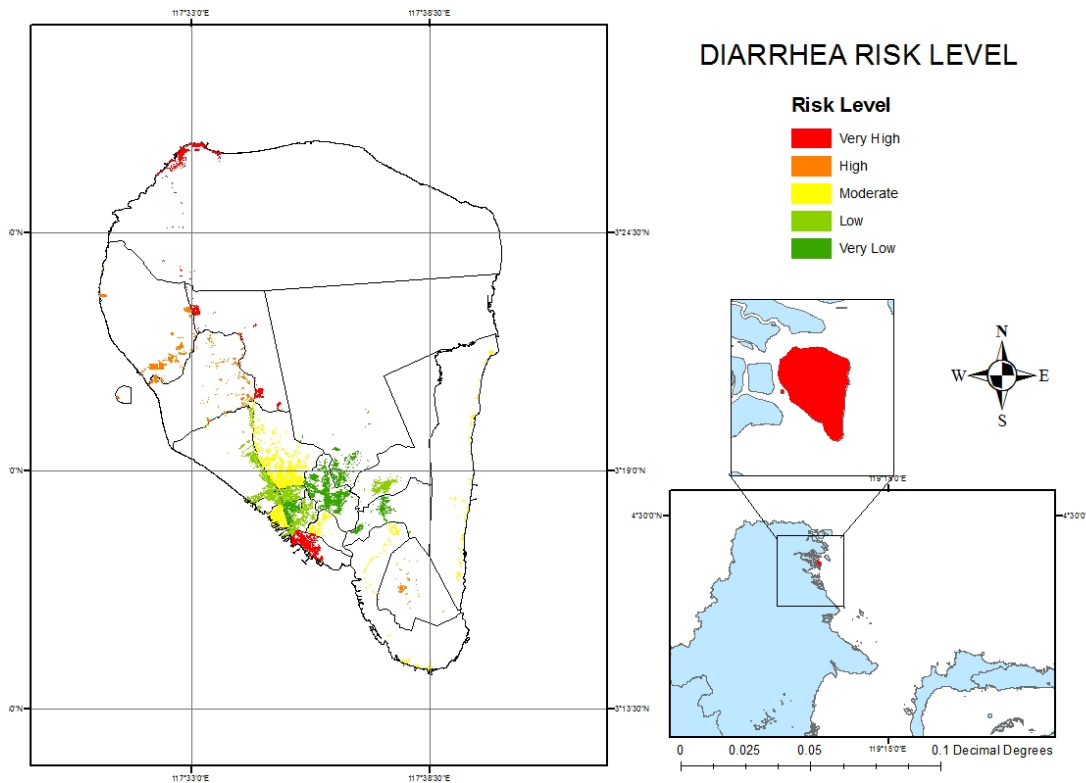

Figure 6. 23 Risk Map of Existing Diarrhea in Tarakan

Figure 6.23 show that Lingkas has the highest risk of diarrhea. Therefore, these areas need more attention and the community needs to enhance the development of local strength toward diarrhea in the future. In general, high total population number becomes the major cause which results in a very high risk of diarrhea.

Table 6. 17 Factors Influencing the Risk Score 2008 in Subdistricts with Very High Risk Score of Diarrhea

Subdistricts with High Risk of Diarrhea	Component	Main Causal Factors
<b>Tarakan Timur</b>		
Lingkas Ujung	Hazard	High prevalence rate of Diarrhea
	Vulnerability	High population density Low piped water coverage
Mamburungan Timur	Vulnerability	Low piped water coverage
		Low availability of toilet
<b>Tarakan Barat</b>		
Karang Harapan	Hazard	High prevalence rate of Diarrhea
<b>Tarakan Utara</b>		
Juata Permai	Hazard	High prevalence rate of Diarrhea
Juata Kerikil	Hazard	High prevalence rate of Diarrhea
	Vulnerability	Low piped water coverage
Juata Laut	Hazard	High prevalence rate of Diarrhea
	Vulnerability	High population density Low availability of toilet

### 6.5.3 Results of Malaria Risk Analysis

Risk of malaria in corresponding villages is determined according to the Risk Assessment Matrix. The results in tabular form are shown in Table 6.18 while the Risk Map is shown in Figure 6.24.

Table 6. 18 Existing Hazard, Vulnerability and Risk to Malaria in Tarakan

Subdistrict	Villages	Hazard		Vulnerability		Risk
		Average Prevalence (2004-2009) /100,000 Occupants	Hazard Level (2004-2009)	Score	Level	
Tarakan Timur	Lingkas Ujung	36.42	Very High	0.84	Very High	Very High
	Gunung Lingkas	36.42	Very High	0.49	Moderate	High
	Mamburungan	0.52	Low	0.63	High	Moderate
	Mamburungan Timur	0.52	Low	0.20	Low	Low
	Kampung Empat	10.58	Moderate	0.28	Low	Low
	Kampung Enam	10.58	Moderate	0.28	Low	Low
	Pantai Amal	10.58	Moderate	0.65	High	High
Tarakan Tengah	Selumit Pantai	0.00	Very Low	0.86	Very High	Moderate
	Selumit	0.00	Very Low	0.79	Very High	Moderate
	Sebengkok	0.00	Very Low	0.64	High	Low
	Pamusian	0.52	Low	0.15	Very Low	Very Low
	Kampung Satu Skip	0.52	Low	0.15	Very Low	Very Low
Tarakan Barat	Karang Rejo	0.00	Very Low	0.82	Very High	Moderate
	Karang Balik	0.00	Very Low	0.24	Low	Very Low
	Karang Anyar	0.00	Very Low	0.15	Very Low	Very Low
	Karang Anyar Pantai	0.00	Very Low	0.70	High	Low
	Karang Harapan	196.96	Very High	0.34	Moderate	High
Tarakan Utara	Juata Permai	196.96	Very High	0.16	Very Low	Moderate
	Juata Kerikil	196.96	Very High	0.28	Moderate	High
	Juata Laut	17.72	High	0.61	Moderate	High

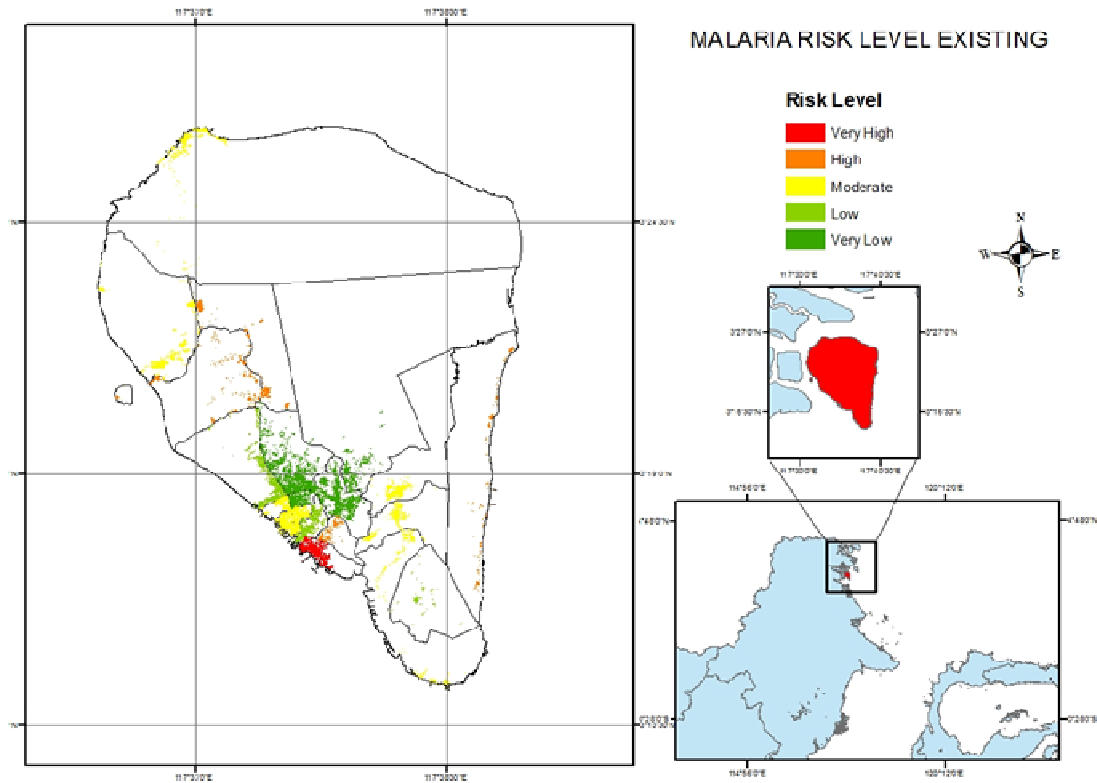

Figure 6. 24 Risk Map of Existing Malaria in Tarakan

Figure 6.24 shows that the southern region of Tarakan elicits a higher risk of increasing the incidence of malaria. Two main components are responsible for the higher risk in certain areas, which are the hazard and vulnerability of malaria. In the future, these components need special attention and to be managed and controlled in order to decrease the incidence of malaria in society. The major cause of a high risk area seems to be multi factorial.

Table 6. 19 Factors Influence the Risk Score 2008 in Tarakan villages with High Risk Score of Malaria

Villages with High Risk of Malaria	Component	Main Causal Factors
<b>Tarakan Timur</b>		
Lingkas Ujung	Hazard	High prevalence rate of malaria
	Vulnerability	Large population run their activity near the breeding site
		Most houses located near the breeding site
		Most people live in non permanent housing
		Low availability of Health Facility
Gunung Lingkas	Hazard	High prevalence rate of malaria
Pantai Amal	Hazard	High prevalence rate of malaria
	Vulnerability	Most people live in non permanent housing
<b>Tarakan Barat</b>		
Karang Harapan	Hazard	High prevalence rate of malaria
<b>Tarakan Utara</b>		
Juata Kerikil	Hazard	High prevalence rate of malaria

## 6.6 Results of Projected Risk Analysis for 2030

Determination of the risk categories for 2030 needs the hazard and vulnerability categories for 2030. It is based on a cross sectional analysis of the risk matrix.

### 6.6.1 Projection Risk of DHF in 2030

The characteristics of each village in Tarakan according to its projection hazard, vulnerability and risk to DHF are outlined in Table 6.20 and illustrated in Figure 6.25 below.

Table 6. 20 Risk Level of DHF Projection for Year 2030 in Tarakan

Subdistrict	Villages	Hazard		Vulnerability		Risk
		Prevalence	Level	Score	Level	
Tarakan Timur	Lingkas Ujung	31.90	Very High	0.39	Very High	Very High
	Gunung Lingkas	38.33	Very High	0.16	Very Low	Moderate
	Mamburungan	27.48	Very High	0.17	Very Low	Moderate
	Mamburungan Timur	15.69	Low	0.18	Very Low	Very Low
	Kampung Empat	40.21	Very High	0.17	Very Low	Moderate
	Kampung Enam	25.03	Very High	0.13	Very Low	Moderate
	Pantai Amal	8.91	Very Low	0.03	Very Low	Very Low
Tarakan Tengah	Selumit Pantai	28.40	Very High	0.43	Very High	Very High
	Selumit	37.08	Very High	0.27	High	Very High
	Sebengkok	30.22	Very High	0.38	Very High	Very High
	Pamusian	28.23	Very High	0.18	Very Low	Moderate
	Kampung Satu Skip	38.92	Very High	0.14	Very Low	Moderate
Tarakan Barat	Karang Rejo	31.07	Very High	0.36	Very High	Very High
	Karang Balik	35.66	Very High	0.33	Very High	Very High
	Karang Anyar	42.11	Very High	0.17	Very Low	Moderate
	Karang Anyar Pantai	18.63	Moderate	0.27	High	High
	Karang Harapan	20.06	Moderate	0.10	Very Low	Low
Tarakan Utara	Juata Permai	32.79	Very High	0.22	Moderate	High
	Juata Kerikil	22.56	High	0.10	Very Low	Low
	Juata Laut	24.41	Very High	0.29	High	Very High

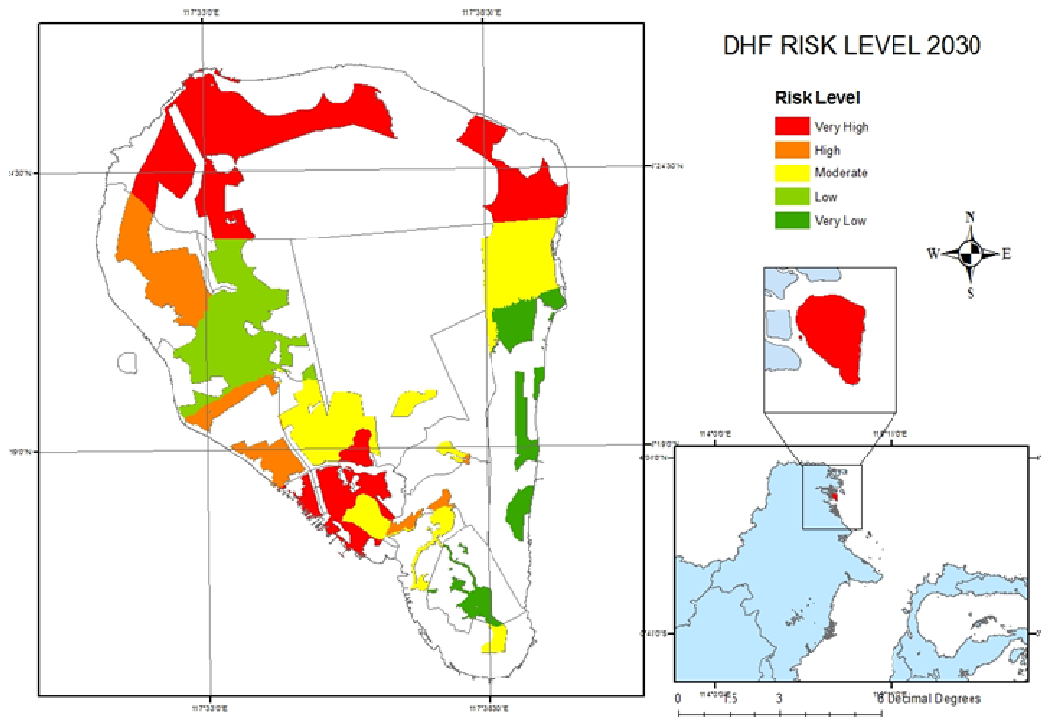

Figure 6. 25 Risk Map of DHF Projection in 2030 in Tarakan

Table 6.21 describes the major factors influencing the very high risk score of DHF in villages of Tarakan in 2030.

Table 6. 21 Factors Influencing the Risk Score in 2030 in Subdistricts with a Very High Risk Score of DHF

Villages with High Risk of DHF	Component	Main Causal Factors
<b>Tarakan Tengah</b>		
Selumit Pantai	Hazard	High prevalence rate of DHF
	Vulnerability	High population density Low availability of health facility
Selumit	Hazard	High prevalence rate of DHF
	Vulnerability	High population density
Sebengkok	Hazard	High prevalence rate of DHF
	Vulnerability	High population density Low piped water coverage
<b>Tarakan Utara</b>		
Juata Laut	Hazard	High prevalence rate of DHF
	Vulnerability	Low piped water coverage
<b>Tarakan Timur</b>		
Lingkas Ujung	Vulnerability	High population density Low availability of health facility
<b>Tarakan Barat</b>		
Karang Rejo	Hazard	High prevalence rate of DHF
	Vulnerability	High population density
Karang Balik	Hazard	High prevalence rate of DHF
	Vulnerability	High population density

### 6.2.2 Projection Risk of Diarrhea in 2030

Projection risk of diarrhea in the corresponding district is determined according to the Risk Assessment Matrix. The results in tabular form are shown in Table 6.22, while the Risk Maps are shown in Figure 6.26.

Table 6. 22 Risk Level of Diarrhea Projection for Year 2030 in Tarakan

Subdistricts	Villages	Hazard		Vulnerability		Risk
		Prevalence	Level	Score	Level	
Tarakan Timur	Lingkas Ujung	60.54	Very High	0.37	High	Very High
	Gunung Lingkas	61.09	Very High	0.29	High	Very High
	Mamburungan	26.50	Moderate	0.34	High	High
	Mamburungan Timur	24.18	Moderate	0.41	Very High	Moderate
	Kampung Empat	24.84	Moderate	0.30	High	High
	Kampung Enam	27.05	Moderate	0.23	Low	Low
	Pantai Amal	27.47	Moderate	0.18	Very Low	Low
Tarakan Tengah	Selumit Pantai	16.82	Low	0.40	Very High	High
	Selumit	14.56	Very Low	0.20	Low	Very Low
	Sebengkok	17.70	Low	0.33	High	Moderate
	Pamusian	21.01	Moderate	0.29	High	High
	Kampung Satu Skip	32.97	Moderate	0.25	Moderate	Moderate
Tarakan Barat	Karang Rejo	30.32	Moderate	0.33	High	High
	Karang Balik	28.52	Moderate	0.28	High	High
	Karang Anyar	15.67	Very Low	0.20	Low	Very Low
	Karang Anyar Pantai	31.14	Moderate	0.46	Very High	High
	Karang Harapan	54.30	Very High	0.24	Low	High
Tarakan Utara	Juata Permai	113.23	Very High	0.26	Moderate	High
	Juata Kerikil	57.72	Very High	0.20	Low	High
	Juata Laut	43.04	High	0.44	Very High	Very High

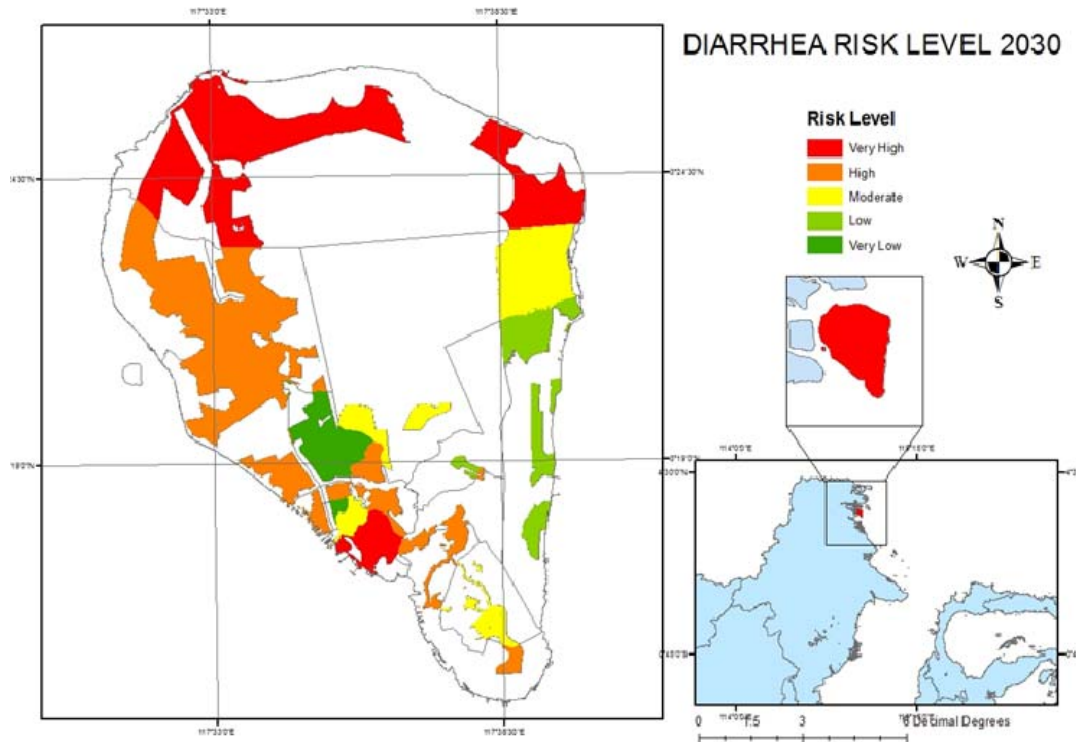

Figure 6. 26 Risk Map of Diarrhea Projection in 2030 in Tarakan

Table 6.23 describes the major factors influencing the very high risk score of diarrhea in villages of Tarakan in 2030.

Table 6. 23 Factors Influencing the Risk Score in 2030 in Subdistricts with a Very High Risk Score of Diarrhea

Subdistricts with High Risk of Diarrhea	Component	Main Causal Factors
<b>Tarakan Timur</b>		
Lingkas Ujung	Hazard	High prevalence rate of Diarrhea
	Vulnerability	High population density Low piped water coverage
Gunung Lingkas	Hazard	High prevalence rate of Diarrhea
	Vulnerability	Low piped water coverage Low availability of toilet
<b>Tarakan Utara</b>		
Juata Laut	Hazard	High prevalence rate of Diarrhea
	Vulnerability	High population density Low availability of toilet

### 6.2.3 Projection Risk of Malaria by 2030

Projection risk of malaria in the corresponding district is determined according to the Risk Assessment Matrix. The results in tabular form are shown in Table 6.24, while Risk Maps are shown in Figure 6.27.

Table 6. 24 Risk Level of Malaria Projection for Year 2030 in Tarakan

Districts	Villages	Hazard		Vulnerability		Risk
		Prevalence (2030) /100,000 Occupants	Hazard Level (2030)	Score	Level	
Tarakan Timur	Lingkas Ujung	11.02	Moderate	0.05	Very Low	Low
	Gunung Lingkas	11.02	Moderate	0.08	Very Low	Low
	Mamburungan	11.02	Moderate	0.08	Very Low	Low
	Mamburungan Timur	11.02	Moderate	0.09	Very Low	Low
	Kampung Empat	11.02	Moderate	0.21	Low	Low
	Kampung Enam	11.02	Moderate	0.42	Moderate	Moderate
	Pantai Amal	11.02	Moderate	0.44	Moderate	Moderate
Tarakan Tengah	Selumit Pantai	0.00	Very Low	0.50	Moderate	Low
	Selumit	0.00	Very Low	0.24	Low	Very Low
	Sebengkok	0.00	Very Low	0.35	Moderate	Low
	Pamusian	0.00	Very Low	0.48	Moderate	Low
	Kampung Satu Skip	0.00	Very Low	0.18	Very Low	Very Low
Tarakan Barat	Karang Rejo	0.00	Very Low	0.78	Very High	Moderate
	Karang Balik	0.00	Very Low	0.77	Very High	Moderate
	Karang Anyar	0.00	Very Low	0.29	Moderate	Low
	Karang Anyar Pantai	0.00	Very Low	0.38	Moderate	Low
	Karang Harapan	0.00	Very Low	0.17	Very Low	Very Low
Tarakan Utara	Juata Permai	64.94	Very High	0.24	Low	High
	Juata Kerikil	64.94	Very High	0.34	Moderate	High
	Juata Laut	64.94	Very High	0.16	Very Low	Moderate



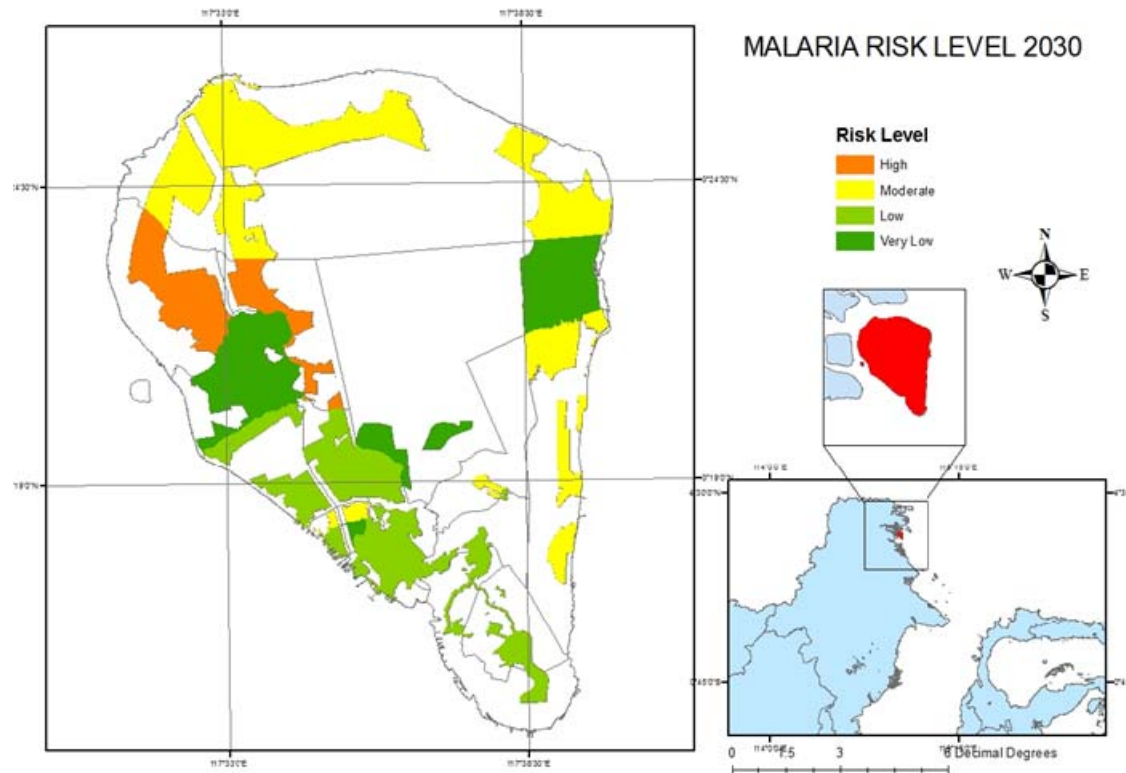

Figure 6. 27 Risk Map of Malaria Projection in 2030 in Tarakan

Table 6.25 describes the major factors influencing the high risk score of malaria in villages of Tarakan in 2030.

Table 6. 25 Factors Influencing the Risk Score in 2030 in Tarakan villages with High Risk Score of Malaria

Villages with High Risk of Malaria	Component	Main Causal Factors
<b>Tarakan Utara</b>		
Juata Kerikil	Hazard	High prevalence rate of malaria
Juata Permai	Hazard	High prevalence rate of malaria

### 6.7 Adaptation Options

In terms of human health, Tarakan is unique in the sense that its general health condition is above the national health standard in many respects. It is known that human health is the result of three synergistic factors, namely genetic, environment and behavior. Recent issues of climate change brought specific alteration in environmental conditions. Specifically, the increment of rainfall and temperature will affect the nature of disease agents. The three guiding principles for the adaptation strategies in the health sector of Tarakan include:

- A policy switch from curative dominance to preventive and promotive activity in the long run.
- Based on the conclusion and prediction drawn by the supporting scientific data which stated that Tarakan's climate is the equatorial type and ENSO influenced, all health planning and adaptation strategy for Tarakan should take into consideration Tarakan's future climate changes.

- The health sector should not be working alone in tackling the situation. A concerted and integrated effort should include other relevant departments. The policy shift in the future may see effort for less short-term (2010-2020) mitigation type of activity and more of a long term (2030-2050) adaptation approach (see Appendix D for a detailed explanation).

Many diseases and health problems that may be exacerbated by climate change in Tarakan can be effectively prevented with adequate financial and human public health resources, including training, surveillance and emergency response, and prevention and control programs. Adaptation enhances a population's coping ability and may protect against current climatic variability as well as against future climatic changes. It includes the strategies, policies, and measures undertaken now and in future to reduce the potential adverse health effects.

The rebuilding and maintaining of public health infrastructure is often viewed as the “most important, cost-effective, and urgently needed” adaptation strategy. Generally, the strategy consists of two major components, which are a proactive strategy that deals with the reduction of climate change effect and a reactive strategy that deals with the enhancement of community strength towards the occurrence of diseases. This chapter is focusing on the adaptation strategy toward Dengue Hemorrhagic Fever (DHF), malaria and diarrhea. Moreover, the adaptation programme is diverse, based on the risk level and the onset of action of each programme.

As discussed in Sub-chapter 3.8, the adaptation strategy in health sector is divided into 4 (four) categories, namely A, B, C, and D, where A is the highest priority area, followed by B, C, and D. The categories are described as follows:

**(A) First priority: Areas with high risk due to high hazard and high vulnerability.**

This high risk area is the first priority to be improved because it has both high hazard and vulnerability. For areas of such criteria, the first attention should be given to the management of hazard against dengue, malaria and diarrhea since patients' wellness is of utmost priority. The next attention is given to the betterment of the environmental quality, provision of a safe water supply, sanitation and health facility.

**(B) Second priority: Adaptation strategy for areas with high risk due to high hazard only.**

This area is a second priority to be improved because it has a high hazard but has low vulnerability. For areas such as this, management of hazard, either for dengue, malaria and diarrhea should be given high attention, both through prevention and treatment. The second attention is the management of the environment such as improvement of a safe water supply, sanitation and clean and healthy environment.

**(C) Third priority: Areas with high risk due to high vulnerability only.**

This area is the third priority to be improved because it has a low hazard but has high vulnerability. For areas such as this, the management of vulnerability is the main attention, such as developing a better and healthier environment, a safe water supply, and environmental sanitation. Management of slum areas and de-urbanization should be integrated within. The improvement of and better access to health facilities should have a high attention and should be adjusted to the real need of the community. For rural areas, improving the access to health facilities

becomes a high focus by either lowering the health cost or by providing public transport facility for easy access.

**(D) Last priority: Areas with low risk due to low hazard and low vulnerability.**

This area is low risk area and last priority to be improved because it has low both hazard and vulnerability. The main task for this area is keep the environment in a healthy condition. Campaigns and community education to prevent both dengue, malaria and diarrhea are also important.

### 6.7.1 Adaptation Option of DHF Risk

Dengue Hemorrhagic Fever is caused by the transmission of the Dengue Virus through vector-borne routes, but basically it could be transmitted through contaminated blood, as in trans-placental cases. Therefore, the adaptation strategy covers the breaking of the transmission chain through elimination of etiologies and its vectors. High risk areas, such as the urban areas, need extra protection since their locations often become the mosquitoes' breeding site. Moreover, the emergency response relies on disease management and the recovery is focussed on disease prevention by means of environmental engineering. In general, the adaptation strategies in Tarakan are as follows:

- **Emergency response:** better DHF management in hospital, clothing, emergency Indoor spraying, repellents, and bednets
- **Recovery:** breeding site reduction, annual Indoor spraying, health education, piped water, drainage & sewerage system, 3M programme (=Menguras-Menutup-Mengubur.. A community programme to wash and clean water storages regularly, to cover water storage containers with lids and to bury all rubbish which might collect water where mosquitoes breed), reduction of rainwater pools, supervision of building construction activities, and health facilities
- **Long term adaptation programme:** pesticide, health reporting and surveillance, healthy housing, anti-viral drug and vaccine, use of long-lasting insecticide-treated materials, universal child immunisation technology, transgenic mosquitoes, depopulation program, deurbanisation, slum area improvement project, governmental insurance system, and law enforcement.

Based on analysing the hazard, vulnerability and risk level both in 2008 and 2030, adaptation strategy categories of DHF for each villages in Tarakan are defined as shown in Table 6.26. Adaptation strategy is defined as A, B, C, and D categories depending on its hazard and vulnerability level.

Table 6. 26 Adaptation Strategy of DHF in Tarakan City

Subdistrict	Villages	Hazard			Vulnerability			Risk			Adap Str.
		2008	2030	Comp.	2008	2030	Comp.	2008	2030	Comp.	
Tarakan Timur	Lingkas Ujung	M	VH	+2	H	VH	+1	H	VH	+1	A
	Gunung Lingkas	H	VH	+1	H	VL	-3	H	M	-1	B
	Mamburungan	L	VH	+3	H	VL	-3	M	M	0	B
	Mamburungan Timur	L	L	0	M	VL	-2	L	VL	-1	D
	Kampung Empat	VH	VH	0	VL	VL	0	M	M	0	B
	Kampung Enam	H	VH	+1	L	VL	-1	M	M	0	B
	Pantai Amal	VL	VL	0	M	VL	-2	L	VL	-1	D

Subdistrict	Villages	Hazard			Vulnerability			Risk			Adap Str.
		2008	2030	Comp.	2008	2030	Comp.	2008	2030	Comp.	
Tarakan Tengah	Selumit Pantai	M	VH	+2	VH	VH	0	H	VH	+1	A
	Selumit	VH	VH	0	VH	H	-1	VH	VH	0	A
	Sebengkok	M	VH	+2	VH	VH	0	H	VH	+1	A
	Pamusian	M	VH	+2	VL	VL	0	L	M	+1	B
	Kampung Satu Skip	H	VH	+1	VL	VL	0	L	M	+1	B
Tarakan Barat	Karang Rejo	L	VH	+3	H	VH	+2	M	VH	+2	C
	Karang Balik	H	VH	+1	VL	VH	+4	L	VH	+3	A
	Karang Anyar	VH	VH	0	M	VL	-2	H	M	-1	B
	Karang Anyar Pantai	VL	M	+1	L	H	+2	VL	H	+3	C
	Karang Harapan	VL	M	+2	L	VL	-1	VL	L	+1	D
Tarakan Utara	Juata Permai	VH	VH	0	M	M	0	H	H	0	B
	Juata Kerikil	L	H	+2	L	VL	-1	L	L	0	B
	Juata Laut	VL	VH	+4	VH	H	-1	M	VH	+2	A

Note: Comp.= comparison Adap Str.= adaptation strategy category

Each category in Table 6.26 has a different adaptation strategy as shown in Table 6.27.

Table 6. 27 Adaptation Strategy for DHF for Each Category in Tarakan

Category	Adaptation Strategy
<b>(A) First priority area: high risk area because it has high both hazard and vulnerability.</b>	<ul style="list-style-type: none"> <li>• Mosquito source reduction</li> <li>• Community and village level of vector management (pesticide fogging program at high incidence and specific locations)</li> <li>• Vaccination on vulnerable population (still on trial)</li> <li>• Whole hospital and Puskesmas emergency alert</li> <li>• Increased Routine surveillance of DHF</li> <li>• Improvement of housing condition</li> <li>• Better piped-water supply and covered water storage</li> <li>• Control of population density</li> <li>• Development of early warning method based on meteorological surveillance</li> </ul>
<b>(B) Second priority area: area that has high hazard but low vulnerability</b>	<ul style="list-style-type: none"> <li>• Mosquito source reduction</li> <li>• Community and village level of vector management (pesticide fogging program at high incidence and specific locations)</li> <li>• Vaccination on vulnerable population (still on trial)</li> <li>• Whole hospital and Puskesmas emergency alert</li> <li>• Increased Routine surveillance of DHF</li> </ul>
<b>(C) Third priority area: area that has high vulnerability but low hazard</b>	<ul style="list-style-type: none"> <li>• Improvement of housing conditions</li> <li>• Better water supply and covered water storage</li> <li>• Control of population density</li> <li>• Development of early warning method based on meteorological surveillance</li> </ul>
<b>(D) Last priority area: area that has low both hazard and</b>	<ul style="list-style-type: none"> <li>• Household level of vector management (Abate, spray cans, mosquito coils, repellents etc.)</li> </ul>

Category	Adaptation Strategy
vulnerability	<ul style="list-style-type: none"> <li>• Routine yearly seasonal spraying</li> <li>• Community awareness programme</li> <li>• Routine implementation of 3M Plus programme</li> <li>• Non-Routine, sentinel surveillance of DHF</li> <li>• Individual patient treatment</li> </ul>

### 6.4.2 Adaptation Options of Malaria

Similar to DHF, hazard, vulnerability and risk level of malaria both in 2008 and 2030 have been analysed and adaptation strategy categories of malaria for each villages in Tarakan are defined as shown in Table 6.28. Adaptation strategy of malaria is defined as A, B, C, and D categories depending on its hazard and vulnerability level following the methodology.

Table 6. 28 Adaptation Strategy Category of Malaria for Each Village in Tarakan

Subdistrict	Villages	Hazard			Vulnerability			Risk			Adap Str.
		2008	2030	Comp	2008	2030	Comp.	2008	2030	Comp.	
Tarakan Timur	Lingkas Ujung	VH	M	-2	VH	VL	-4	VH	L	-3	A
	Gunung Lingkas	VH	M	-2	M	VL	-2	H	L	-2	B
	Mamburungan	L	M	+1	H	VL	-3	M	L	-1	C
	Mamburungan Timur	L	M	+1	L	VL	-1	L	L	0	D
	Kampung Empat	H	M	-1	L	L	0	M	L	-1	B
	Kampung Enam	H	M	-1	L	M	+1	M	M	0	B
	Pantai Amal	H	M	-1	H	M	-1	H	M	-1	A
Tarakan Tengah	Selumit Pantai	VL	VL	0	VH	VH	0	M	L	-1	C
	Selumit	VL	VL	0	VH	VH	0	M	VL	-2	C
	Sebengkok	VL	VL	0	H	M	-1	L	L	0	C
	Pamusian	L	VL	-1	VL	M	+2	VL	L	+1	D
	Kampung Satu Skip	L	VL	-1	VL	VL	0	VL	VL	0	D
Tarakan Barat	Karang Rejo	VL	VL	0	VH	VH	0	M	M	0	C
	Karang Balik	VL	VL	0	L	VH	+3	VL	M	+2	C
	Karang Anyar	VL	VL	0	VL	M	+2	VL	L	+1	D
	Karang Anyar Pantai	VL	VL	0	H	M	-1	L	L	0	C
	Karang Harapan	VH	VL	-4	M	VL	-2	H	VL	-3	B
Tarakan Utara	Juata Permai	VH	VH	0	VL	L	+1	M	H	+1	B
	Juata Kerikil	VH	VH	0	M	M	0	H	H	0	B
	Juata Laut	M	VH	+2	M	VL	-2	M	M	0	D

Note: Comp = comparison, Adap Str. = adaptation strategy category

Each category in Table 6.28 has a different adaptation strategy as shown in Table 6.29.

Table 6. 29 Adaptation Strategy for Malaria for Each Category in Tarakan

Category	Adaptation Strategy
<b>(A) First priority area: high risk area because it has high both hazard and vulnerability.</b>	<ul style="list-style-type: none"> <li>• Mosquito source reduction</li> <li>• Citywide level of malaria vector management (pesticide fogging program at high incidence and specific locations)</li> <li>• Vaccination on vulnerable population (currently still on development)</li> <li>• Whole hospital emergency alert</li> <li>• Increased routine surveillance of malaria</li> <li>• Improvement of housing condition</li> <li>• Meteorological surveillance (rainfall, temperature)</li> <li>• Coastal reclamation (drying of swamps and lagoons)</li> <li>• Mangrove re-forestation</li> <li>• Legislative measures (enforcement of existing regulation on environment and health)</li> </ul>
<b>(B) Second priority area: area that has high hazard but low vulnerability</b>	<ul style="list-style-type: none"> <li>• Mosquito source reduction</li> <li>• Citywide level of malaria vector management (pesticide fogging program at high incidence and specific locations)</li> <li>• Vaccination on vulnerable population (currently still on development)</li> <li>• Whole hospital emergency alert</li> <li>• Increased routine surveillance of malaria</li> </ul>
<b>(C) Third priority area: area that has high vulnerability but low hazard</b>	<ul style="list-style-type: none"> <li>• Improvement of housing conditions</li> <li>• Meteorological surveillance (rainfall, temperature)</li> <li>• Coastal reclamation (drying of swamps and lagoons)</li> <li>• Mangrove re-forestation</li> <li>• Legislative measures (enforcement of existing regulation on environment and health)</li> </ul>
<b>(D) Last priority area: area that has low both hazard and vulnerability</b>	<ul style="list-style-type: none"> <li>• Household level of mosquito bites prevention (Abate, spray cans, mosquito coils, repellents etc.)</li> <li>• Routine annual or twice per year seasonal spraying</li> <li>• Community malaria awareness program</li> <li>• Depend on cases, non-routine (sentinel surveillance of Malaria species) or routine mosquito quarterly surveillance (measurement of mosquito density index)</li> <li>• Availability and provision of prophylactic anti malaria tablets</li> <li>• Individual patient treatment</li> </ul>

### 6.4.3 Adaptation Options of Diarrhea

By using a similar methodology to that used for DHF and malaria, hazard, vulnerability and risk level of diarrhea both in 2008 and 2030 have been analysed and adaptation strategy categories of diarrhea for each village in Tarakan are defined as shown in Table 6.30. Adaptation strategy of diarrhea is defined as A, B, C, and D category depending on its hazard and vulnerability level.

Table 6. 30 Adaptation Strategy Category of Diarrhea for Each Village in Tarakan

Subdistrict	Villages	Hazard			Vulnerability			Risk			Adap Str.
		2008	2030	Comp.	2008	2030	Comp.	2008	2030	Comp.	
Tarakan Timur	Lingkas Ujung	VH	VH	0	H	VL	-3	VH	VH	0	A
	Gunung Lingkas	VH	VH	0	VL	VL	0	M	VH	+2	B
	Mamburungan	L	M	+1	H	VL	-3	M	H	+1	C
	Mamburungan Timur	L	M	+1	VH	VL	-4	H	M	-1	C
	Kampung Empat	VL	M	+2	L	L	0	VL	H	+3	D
	Kampung Enam	VL	M	+2	H	M	-1	L	L	0	C
	Pantai Amal	VL	M	+2	VH	M	-2	M	L	-1	C
Tarakan Tengah	Selumit Pantai	VL	L	+1	VH	M	-2	M	H	+1	C
	Selumit	VL	VL	0	L	L	0	VL	VL	0	D
	Sebengkok	VL	L	+1	M	M	0	L	M	+1	D
	Pamusian	L	M	+1	VL	M	+2	VL	H	+3	D
	Kampung Satu Skip	L	M	+1	VL	VL	0	VL	M	+2	D
Tarakan Barat	Karang Rejo	M	M	0	L	VH	+3	L	H	+2	D
	Karang Balik	M	M	0	VL	VH	+4	L	H	+2	D
	Karang Anyar	M	VL	-2	M	M	0	M	VL	-2	D
	Karang Anyar Pantai	M	M	0	L	M	+1	L	H	+3	D
	Karang Harapan	VH	VH	0	M	VL	-2	H	H	0	B
Tarakan Utara	Juata Permai	VH	VH	0	M	L	-1	H	H	0	B
	Juata Kerikil	VH	VH	0	H	M	-1	VH	H	-1	A
	Juata Laut	H	H	0	VH	VL	-4	VH	VH	0	A

Note: Comp = comparison, Adap Str. = adaptation strategy category

Each category in Table 6.30 has different adaptation strategy as shown in Table 6.31

Table 6. 31 Adaptation Strategy for Diarrhea for Each Category in Tarakan

Category	Adaptation Strategy
(A) First priority area: high risk area because it has high both hazard and vulnerability.	<ul style="list-style-type: none"> <li>• Whole hospital emergency alert and increased access to emergency treatment. If epidemic warning (KLB) occurs do citywide hospital alert and decrease in morbidity and mortality</li> <li>• Availability of drugs and antibiotic against diarrhea and develop rapid diarrheal diagnostic agents</li> <li>• Better training of hospital personnel during emergency diarrheal outbreak and increased routine surveillance of diarrhea agents</li> <li>• Meteorological surveillance (rainfall, temperature) and development of early warning method based on meteorological surveillance</li> <li>• Increased community participation</li> <li>• If flood occurs, establish better sanitation systems in flood refugee camps</li> <li>• Development of drainage infrastructure in flood prone areas</li> <li>• Widening and deepening of existing drains and canals</li> <li>• Improvement of household sewer system and adaptation of greywater usage</li> <li>• Legislative measures (enforcement of existing regulation on</li> </ul>

Category	Adaptation Strategy
	environment and health) <ul style="list-style-type: none"> <li>• Kampung (villages) improvement sanitation program</li> <li>• Extensive use of piped-water (PDAM) and increased of household piped-water</li> </ul>
(B) Second priority area: area that has high hazard but low vulnerability	<ul style="list-style-type: none"> <li>• Whole hospital emergency alert and increased access to emergency treatment. If epidemic warning (KLB) occurs do citywide hospital alert and decrease in morbidity and mortality</li> <li>• Availability of drugs and antibiotic against diarrhea and develop rapid diarrheal diagnostic agents</li> <li>• Better training of hospital personnel during emergency diarrheal outbreak and increased routine surveillance of diarrhea agents</li> <li>• Meteorological surveillance (rainfall, temperature) and development of early warning method based on meteorological surveillance</li> <li>• Increased community participation</li> <li>• If flood occurs, establish better sanitation systems in flood refugee camps</li> <li>•</li> </ul>
(C) Third priority area: area that has high vulnerability but low hazard	<ul style="list-style-type: none"> <li>• Development of drainage infrastructure in flood prone areas</li> <li>• Widening and deepening of existing drains and canals</li> <li>• Improvement of household sewer system and adaptation of greywater usage</li> <li>• Legislative measures (enforcement of existing regulation on environment and health)</li> <li>• Kampung (villages) improvement sanitation program</li> <li>• Extensive use of piped-water (PDAM) and increased of household piped-water</li> <li>• Improvement of health facility</li> </ul>
(D) Last priority area: area that has low both hazard and vulnerability	<ul style="list-style-type: none"> <li>• Household level of waterborne disease prevention</li> <li>• Boiling of household water</li> <li>• Non-Routine, sentinel surveillance of diarrhea agents</li> <li>• Soap and clean water hand washing training as prophylaxis against hand to mouth infection</li> </ul>

In addition to all adaptation options, many diseases and health problems that may be exacerbated by climate change in Tarakan can be effectively prevented with adequate financial and human public health resources, including training, surveillance and emergency response, and prevention and control programs. Adaptation enhances a population's coping ability and may protect against current climatic variability as well as against future climatic changes. It includes the strategies, policies, and measures undertaken now and in future to reduce the potential adverse health effects.



## 7. Multi-risk Assessment and Adaptation Prioritisation

### 7.1 Multi-risk Assessment

A multi-risk assessment is basically conducted to achieve a more comprehensive view of climate risk faced by Tarakan City. To some extent, this effort would help to determine more appropriate adaptation actions, to become a baseline for a comprehensive adaptation action plan for Tarakan City, as well as to help in mainstreaming the adaptation action towards development and spatial plans.

As technical steps to develop a multi-risk assessment matrix, the following steps were performed for each unit analysis (for Tarakan City context is Subdistrict):

1. Identification of the highest hazard level for each type of hazard.
2. Identification of the highest vulnerability components for each type of hazard.
3. Identification of the highest risk level, for each type of hazard.
4. Identification of areas with multiple high risks.

The following figures are risk level maps of each hazard in Tarakan Ciy in 2030.

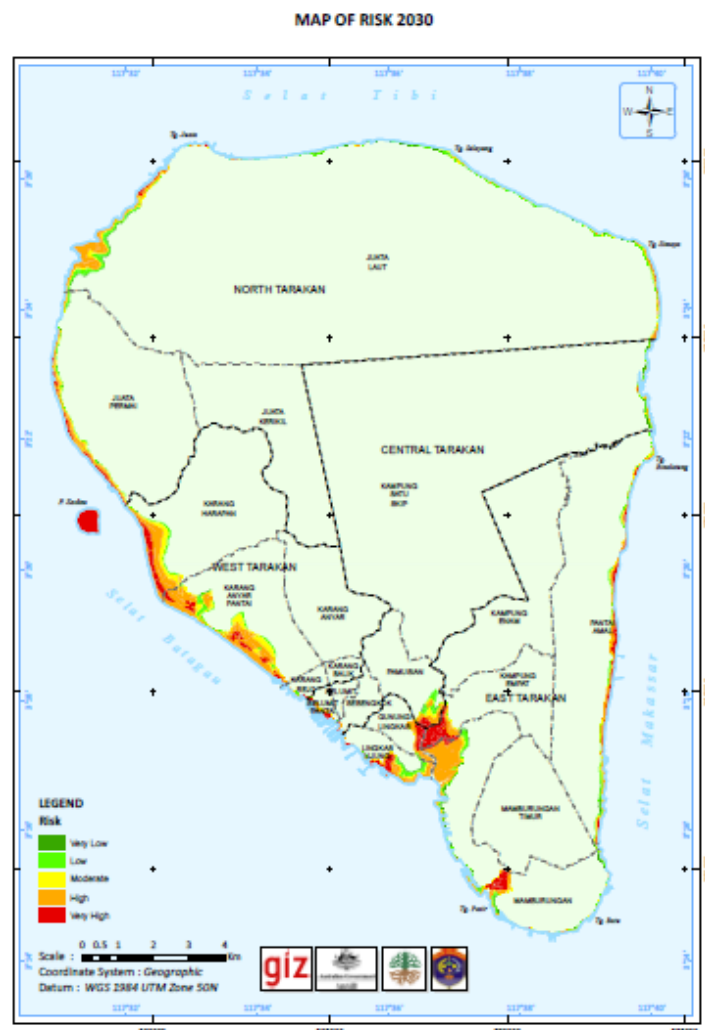

Figure 7. 1 Coastal Inundation Risk in 2030

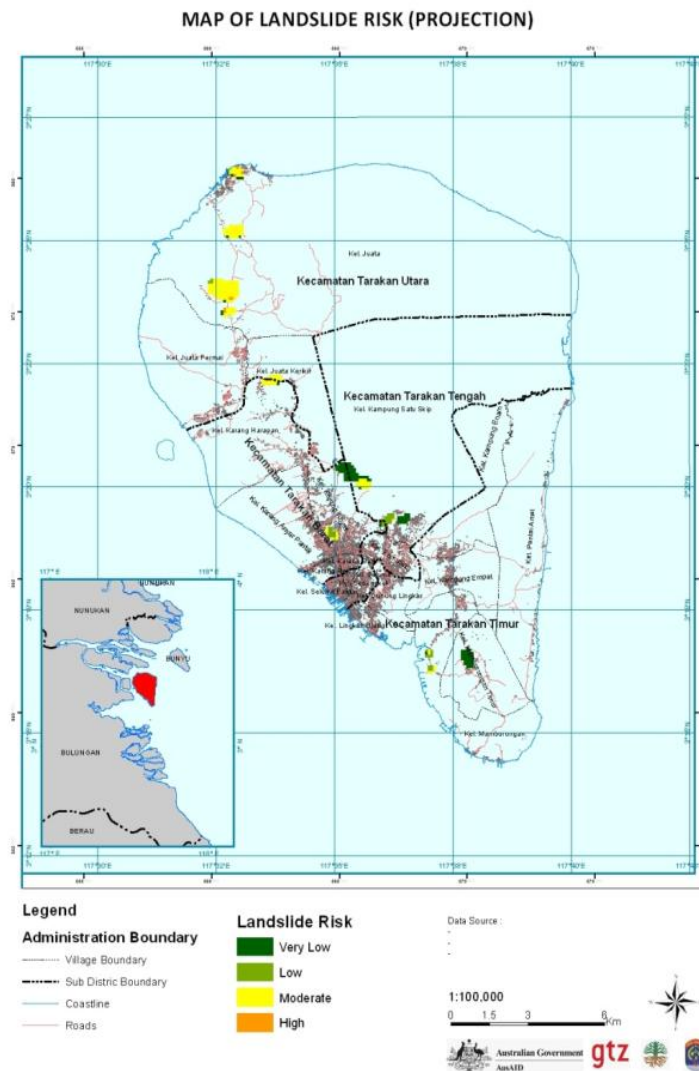

Figure 7. 2 Landslide Risk in 2030

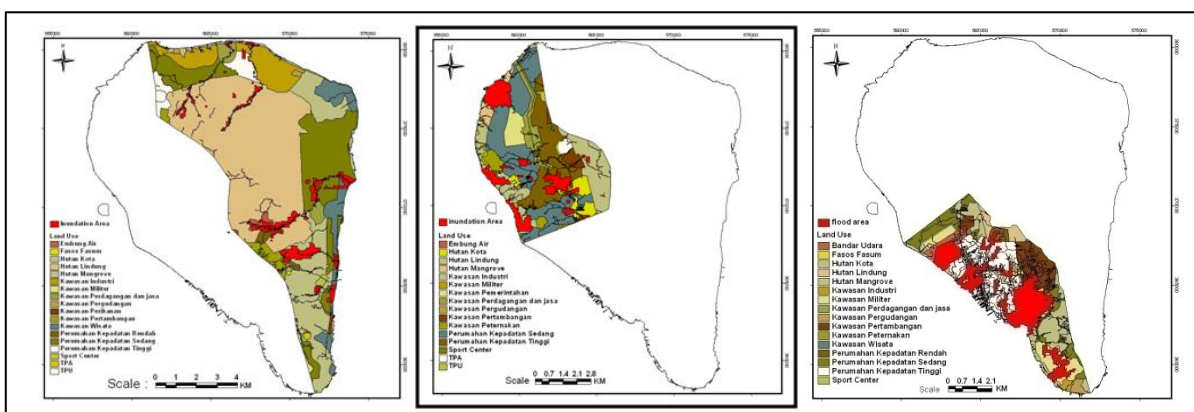

Figure 7. 3 Flood Risk in 2030 on 3 Areas

From the overlay of coastal and water sector risk maps shown above we can see that the Western part of Tarakan is the most prone area to climatic hazard of coastal inundation and flooding. This area is physically mainly characterised by a plain with fine relief (1-2 m), low elevation (0-10 m above sea level/m.asl), and slopes less than

5%. With current land use of residential, commercial and industrial areas, and with high population density, which makes it highly vulnerable; the area is very highly at risk from inundation and flooding. Villages such as Lingkas Ujung, Gunung Lingkas, Selumit Pantai, and Karang Anyar Pantai are the worst areas that may be affected by climatic hazards.

The above climatic hazards may lead to or intensify other hazards to humans, such as those which have been identified in health sector. Three types of disease have been identified as being associated with climate change, i.e. dengue fever, malaria and diarrhea. For Tarakan City, dengue fever is the disease whose correlation with climate change is most identifiable. From the projected risk map of dengue fever we can see how the Western part of Tarakan is still the most prone area to dengue fever. The high population densities have made the area highly vulnerable in disease transmission. Villages such as Selumit Pantai, Selumit, Karang Anyar, and Lingkas Ujung are thus the highest risk areas to dengue fever.

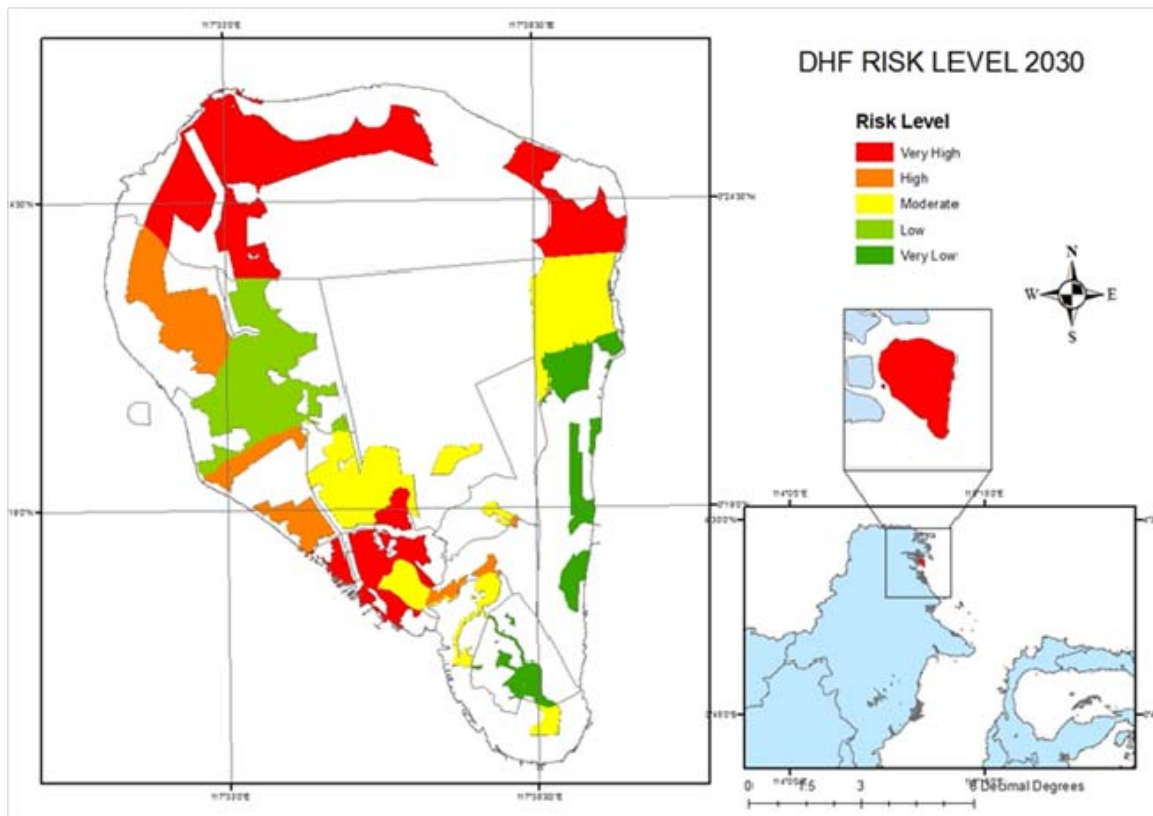

Figure 7. 4 Dengue Fever Risk in 2008

## 7.2 Prioritised Areas for Adaptation

To avoid the perception that adaptation to climate change was only a shopping-list and segregated from development plans, prioritisation needs to be done. The adaptation prioritisation is conducted through an iterative process of short-listing the area based on its vulnerability components. As follows, here are the steps to determine the adaptation prioritisation:

1. Classification of existing and projected risk.
2. Identification of single or multiple sectors affected by particular risk.
3. Identification of risk location, whether located in strategic or non strategic area.
4. Identification of risk location, whether located in large area or not.
5. Identification of vulnerability component that can be reduced (its exposure) or increase its adaptive capacity

From the multi-risk assessment above, it has been identified that the Western part of Tarakan is the area most highly at risk to climatic hazards as well as derived hazards. In other words, the Western part of Tarakan is an area of cascading risks from climate change, thus adaptation strategy for this area should be prioritized by the government.

In the coastal sector, the area is identified with its typically dense population (settlements) and economic activities, and also containing some wetlands and mangroves. Thus the concept of adaptation proposed in this area is accommodation – protection strategy followed by mangrove restoration. As for the water sector, especially to adapt to flooding risk, the adaptation strategy proposed is the installation of sluice gates at the river, levees, and pumping. Installation of sluice gates may prevent tidal water entering, as its installation on the upstream is dedicated to avoid inundation in the downstream.

As for the health sector, in order to adapt to the risk of dengue fever, adaptation strategies proposed for the whole of Tarakan are as follows:

- **Emergency response**: better DHF management in hospitals, clothing, emergency indoor spraying, repellents, and bed-nets.
- **Recovery**: breeding site reduction, annual indoor spraying, health education, piped water, drainage and sewerage system, 3M programme (= *Menguras-Menutup-Mengubur*). A community programme to wash regularly and clean water storage containers, to cover water storage containers with lids and to bury all rubbish which might collect water where mosquitoes breed), reduction of rainwater pools, supervision of building construction activities, and health facilities.
- **Long term adaptation program**: pesticide, health reporting and surveillance, healthy housing, anti-viral drug and vaccine, use of long-lasting insecticide-treated materials, universal child immunisation technology, transgenic mosquitoes, de-population program, de-urbanisation, slum area improvement project, governmental insurance system, and law enforcement.

In terms of implementation of these adaptation options, there are four scenarios of adaptation prioritisation according to the following criteria: multi-risk level, total population, vital infrastructure and existence of built-up areas, as well as wetlands and mangrove (ecosystem) areas. Brief explanations of each priority scenario are given below:

- There are three villages having a very high level of multi-risk, i.e., Selumit Pantai in Central Tarakan subdistrict as well as Lingkas Ujung and Gunung Lingkas in East Tarakan sub-district.
- The top-five risky villages with largest population are Karang Anyar Pantai, Selumit Pantai, Sebengkok, Pamusian, and Lingkas Ujung.

- According to vital infrastructure and built-up areas, several risky villages need to be prioritised, i.e. Karang Harapan, Karang Anyar Pantai, Mamburungan, Pantai Amal, and Juata Permai. Brief descriptions of the villages are given as follows:
  - Karang Harapan, Juata Permai, and Mamburungan villages up until year 2030 will become significant industrial areas.
  - Villages with significant settlements are Karang Anyar Pantai, Kampung Empat, and Pantai Amal.
  - Karang Anyar Pantai also require further protection for vital infrastructure, as the Juata Airport is situated within the subdistrict.
- Forest and mangrove restoration, living shoreline and environmental protection adaptation strategies become the highest priority in the top-five villages with the largest sizes of forest, wetlands and mangrove (ecosystem) areas, i.e. Juata Laut, Karang Anyar Pantai, Juata Permai, Lingkas Ujung, and Pamusian.

## 8. Mainstreaming CCRAA into Development Planning

The results of the Climate Change Risk and Adaptation Assessment (CCRAA) should be mainstreamed into local development planning and policy in order to give better direction in development.

The process in mainstreaming CCRAA results involves several steps, including the identification of themes in national, provincial, or local plans that are related to CCRAA. These documents include the Local Long-Term Development Plan (RPJPD) 2005-2025, the Local Medium-Term Development Plan (RPJMD) 2010-2014 and Local Annual Development Plan (RKPD) 2013, as well as the General Spatial Plan (RTRW) 2010-2030. The purpose of identifying these themes in Tarakan City's documents is to find the entry points for discussion with stakeholders on issues addressed by the CCRAA so that they have "hooks" into the existing documents.

Ideally, the CCRAA should be mainstreamed into all local development plans. However, at the time of this assessment, the City Government of Tarakan has already established a Local Regulation (Peraturan Daerah) on the RPJP, RPJM, and RTRW. Hence, the current mainstreaming process is only conducted into the RKP. The other development plans are only reviewed and expected to be mainstreamed in the near future.

In line with the above process, preferred adaptation options are also identified by stakeholder consultation. In this process, the factors that determine the likelihood of executing the adaptation options proposed by experts are identified.

A further step is working with government officials, especially from the Regional Development Planning Agency (Bappeda), on the compatibility analysis between the preferred adaptation options and the existing programmes or activities stipulated in the RKPD. The purpose is to make recommendations on which adaptation options need to be mainstreamed further in the next annual development plan of the local government.

Following these recommendations, focus group discussions involving local and central government officials from their respective sectors are conducted with the purpose of synchronising programmes or activities recommended by local governments with those of central government. At this stage, we identify which central government office manages a programme or activity similar to the one recommended by the previous step, as well as to identify the potential funding mechanism to implement the programme or activity.

The final step in mainstreaming the findings of the CCRAA into development planning is that of formulating the champion programmes for each region, based on the recommendations from the earlier process, i.e. the adaptation prioritisation. These champion programmes are submitted to central government in order to get funding commitment either from state budget or non-state budget, including international funds.

The diagram below captures the mainstreaming process elaborated above.

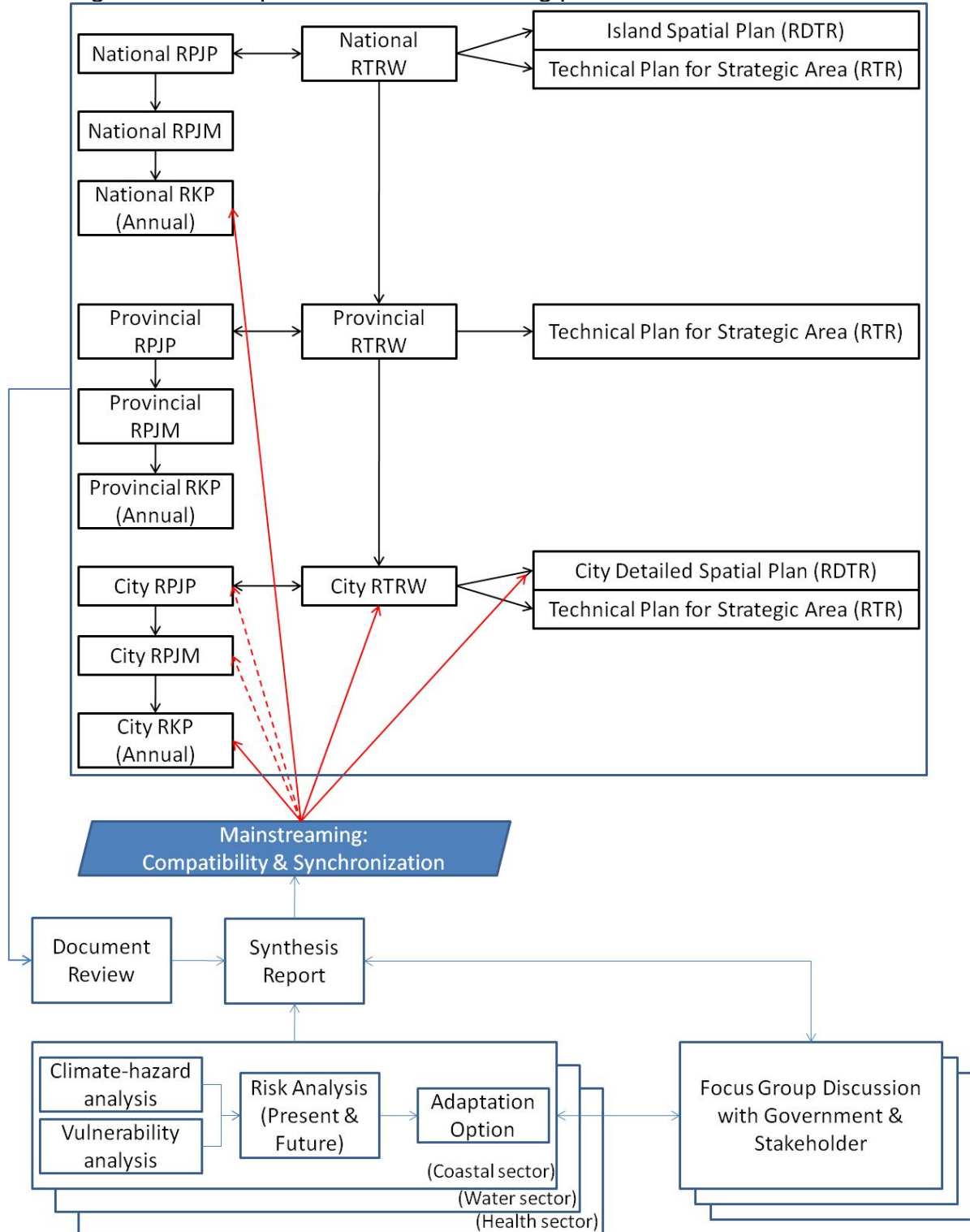

Figure 8. 1 CCRAA Process and Mainstreaming into Development Planning in Tarakan City

## 8.1 Review of Local Long-Term and Medium-Term Development Plans

Several development plans exist in every locality in Indonesia and this chapter will briefly show the current substance of development plans in Tarakan City; i.e. The Long-Term Development Plan (RPJPD) and The Medium-Term Development Plan (RPJMD). The latest RPJPD will be legal for the period of 2005 until 2025, whereas the latest RPJMD is for the period 2010 – 2014. Several strategic matters that have correlation with the CCRAA process and output will be pinpointed, as the basis for the next study phase.

### 8.1.1 Tarakan City RPJP 2005 – 2025

As a long term development plan, The RPJP has stated the vision for the twenty years of development; i.e. *Kota Tarakan sebagai Pusat Pelayanan, Perdagangan, dan Jasa Menuju Masyarakat yang Sejahtera dalam Lingkungan Hidup Berkelanjutan* - Tarakan City as a commerce and service centres to achieve a prosperous society in a sustainable environment. The vision is then followed by 5 development missions, with each mission having its own strategies and development path. As follows, here are the various development missions, strategies, and development paths stated in Tarakan City RPJP 2005 – 2025 (numbering as original in the document) that may be coherent with the CCRAA process and output:

Table 8. 1 Contents of Tarakan City RPJP Related to CCRAA

Development Missions	Strategies	Development Policy
B. Developing modern city infrastructure	b. Development of outer ring road to enhance activities in coastal area. d. Development of international standard sea port. g. Enhancement of a water dam to improve clean water in terms of quantity and quality. k. Improvement for slum area.	m. Improvement to infrastructure network accessibility (energy, telecommunication, and clean water). n. Disposition for slum areas.
C. Developing quality of human resources (competitive advantage and noble character) through qualified education and health service	h. Provision of adequate, qualified, and modern health facilities. i. Equity health services j. Provision of international standard hospital k. Provision of health insurance for all society	g. Enhancement of society's awareness for healthy living and behaviour i. Improvement of quantity and quality of health facilities. j. Developing Local Hospital (RSUD) Tarakan as a primary hospital in North Kalimantan k. Equitable provision of health facilities and medical personnel l. Eradication of contagious diseases p. Improvement on quantity and quality of medical personnel s. Affordable health cost policy for the society u. Optimisation of health infrastructure v. Equitable health facilities for all subdistricts.
D. Improving the quality of	a. Natural resource	a. Preservation of mangrove, gardens,



Development Missions	Strategies	Development Policy
the environment towards a green city	<p>management which address economical and ecological concern.</p> <p>b. Maintain and preserve garden cities, urban forest, and mangrove.</p> <p>c. Eradication of slum areas.</p>	<p>and urban forest.</p> <p>e. Environmental management for estuary to overcome flood risk</p> <p>f. Area enhancement of city gardens, urban forest, and mangrove</p> <p>g. Strengthening quality of gardens, urban forest and mangrove</p>

Source: Based on Tarakan City RPJP 2005 – 2025

The Tarakan City RPJP vision, mission, strategies, and development policy are then equipped with long term development scenarios and stages. There are two main development scenarios; i.e. Economical Development Scenario and Environmental Development Scenario. The CCRAA output may be used to enrich the substance of the Environmental Development Scenario with regard to the issues related to health and infrastructure quality.

In terms of development stages, the Long-Term Development Plan will be achieved through four Medium-Term Development Plans (Tarakan City RPJMD). The stages are divided as follows:

1. 1<sup>st</sup> Tarakan City RPJMD (2005 – 2009)
2. 2<sup>nd</sup> Tarakan City RPJMD (2010 – 2014)
3. 3<sup>rd</sup> Tarakan City RPJMD (2015 – 2019)
4. 4<sup>th</sup> Tarakan City RPJMD (2020 – 2025)

The current Climate Risk and Adaptation Assessment is being conducted alongside the 2<sup>nd</sup> term of The Tarakan City RPJMD; i.e. for the 2010 – 2014 period. Based on the Tarakan City RPJPD 2005 – 2025, this 2<sup>nd</sup> medium term development should address several key points as follows:

Table 8. 2 Key Points on RPJP Guidance for RPJM 2010 – 2014 and Its Relation with CCRAA

Policy Theme	Key points and Relation with CCRAA
Economical Development	<ul style="list-style-type: none"> <li>• Economic growth 7% - 8%</li> <li>• Strong economic structure with economic base on commerce and services, fisheries industry, and small-medium enterprises</li> <li>• Per capita income US \$ 4000 – 6000</li> <li>• Decrease unemployment rate 5% - 7%</li> <li>• Decrease poverty rate 6% - 8%</li> </ul>
Human Resources Development	In this term, the human resources development policy will assure adequate and equitable provision of health and education facilities. Related with to health sector, as part of the CCRAA, at the end of the period, it is expected that there are several outputs; i.e. International Hospital as reference for North Kalimantan and also eradication of several communicable disease.
Urban Infrastructure Development	Urban infrastructure development is being dedicated to provide adequate support for business and attracting possible investment; i.e. including development of road networks, seaport, airport, electricity, clean water, and telecommunication. The parts of this policy that are related to the CCRAA are as follows: development of ring road for coastal area, improvement on Juwata Airport, improvement on seaport, and enhancement on dam and clean water (PDAM) network (at least 50% of society gained access to the network)
Environment	Here are several key points on environmental development policy that has relation

al Development	with the CCRAA: a) prevention and control of environmental degradation, b) preservation of water resources, c) river management, d) sustainable coastal development, e) preservation of gardens, urban forest, and mangrove, and f) eradication of slum areas.
Politics, Law, Security, and Governance	This policy strongly secures the legal grounding. Thus, it is related and warrants the assumption that the spatial plan being analysed in the CCRAA will be fully implemented.

Source: Summarized from RPJP 2005 – 2025, p.102 – 106

### 8.1.2 Tarakan City RPJM 2010 – 2014

Tarakan City RPJPM 2010 – 2014 is developed as guidance for governance, development management, and services provision for the people of Tarakan. It is expected that the RPJM outlines development programmes for a five year period. The contents of the RPJM are structured as follows: a) Introduction, b) Overview of Tarakan City, c) Vision-Mission-Goals, d) Development Strategy, e) Development Policy and Program, f) Priority Program, g) Development Performance Indicator, and h) Transition Guidance and Implementation Principles.

The 1<sup>st</sup> chapter of the RPJM describes the purpose of the document and how it is related to other development planning documents.

The 2<sup>nd</sup> chapter of the RPJM covers several characteristics of Tarakan City; i.e. geographical conditions, economy of the city, social and cultural aspects, infrastructure, government, financial situation, and strategic issues. However, the geographical profile only covers general information regarding the basic physical profile such as size, topography, geology, climate, current land use, etc in which only single year (2007 or 2008) data is shown. Nevertheless, this part has mentioned several environmental problems that may relate to climate change; i.e. the problem of mangrove areas, sea water intrusion, abrasion, and pollution<sup>4</sup>. As for the city's economy, it describes the condition of gross domestic regional product, economic growth, and the structure of the economy, profile of each sector, inflation, and investment using data from the period 2000 until 2007<sup>5</sup>. At this point, it may be related to the coping or adaptive capacity of the city and also may be used as an entry point for addressing vulnerable sectors (for instance fisheries). The description of Tarakan's social and cultural components describe population growth, density; and structure, population projection for the coming five years, poverty, human development index, health, and labour<sup>6</sup>. This profile may be used for analysing the vulnerable groups in Tarakan; however the document doesn't provide long term data and future analysis of the data. On the other hand, the document provides conditions of several facilities and infrastructure as follows: religion, housing, education, health, commerce and services, transportation, green open space, clean water, waste, drainage, sewerage, and electricity; however the data being used is only from a short time period and it is fairly general without being attached to a geographical information system.

<sup>4</sup> See Tarakan City RPJM 2010 – 2014, p. 9 – 17

<sup>5</sup> See Tarakan City RPJM 2010 – 2014, p. 17 – 33

<sup>6</sup> See Tarakan City RPJM 2010 – 2014, p. 33 – 39

The profile of government and the fiscal balance of Tarakan City is given in the next section of the same chapter of the document and may give a hint on the adaptive capacity that may be possible for the introduction of the measures identified in the CCRAA. Lastly, the chapter identifies several strategic issues that Tarakan City faces. Below is a table of several strategic issues mentioned by the Tarakan City RPJM that may have relation to the CCRAA.

Table 8. 3 Issues Addressed by RPJM 2010–2014 and Its Possible Relation to the CCRAA

Type of Issue	Relation with CCRAA
City economic development	Un-optimisation on fisheries sector
Human Resources Development	Challenges on international standard health facility provision High rate of poverty High rate of unemployment
Urban Infrastructure Development	The necessity to improve clean water provision The necessity to improve seaport Flood The low rate of carrying capacity for housing development
Environmental Development	Provision of basic water quantity and quality Controlling for preserved city area The necessity of complete, qualified, and actual environment data
Politics, Law, Security, and Government	The necessity to improve society's awareness of social and physical environmental issues.

Source: Summarized from Tarakan City RPJM 2010 – 2014, p. 71 – 72

Based on these strategic issues, the 3<sup>rd</sup> chapter of Tarakan City RPJM states the development vision for five years term as follows: *Mewujudkan Kota Tarakan menjadi Pusat Perdagangan dan Jasa serta Pusat Pelayanan Pendidikan dan Kesehatan, yang andal dan sejahtera serta berkelanjutan* – Tarakan City as a Centre for commerce and services as well as an education and health centre, which is reliable, prosperous, and sustainable. The vision is then followed by development missions, goals, and strategies. Below are the lists of those having a relation to the CCRAA (numbering as original in the document):

Table 8. 4 RPJM Development Mission, Goals, and Strategies which has Relation with CCRAA

Development Mission	Goals	Strategies
2. Develop a qualified health and education facilities for other islands/areas in Kalimantan 4. Implementation of healthy and sustainable city development	4. Just and optimal education and health service provision 12. City infrastructure that fulfilled minimum service standard (SPM) 13. Enhancement of city environment quality	9. Improving health services 23. Improving clean water provision capacity and scope 28. Enhancing seaport 29. Enhancing the capacity of city drainage 33. Development of housing for society 35. Developing water recharge area 36. Controlling preservation of preserve area 39. Developing city environment database

Source: Summarized from Tarakan City RPJM 2010 – 2014, p. 76 – 77

These vision-mission-goals-strategies are then followed by the arrangement of development policy and programme in chapter 5, either as mandatory or optional governmental affairs as being stated in Government Regulation (PP) No. 38/2007.

Below are the development policy and programmes that may be related to the CCRAA:

Table 8. 5 Tarakan City RPJM Development Policy and Programme 2010 – 2014

Sectors	Policy	Program
Health	Supporting the needs of medical personnel Equating health facility services Facilitating health support for poor people Developing Health information system Increasing health index	Improvement of medical personnel competency Development of hospitals Development of health centres (Puskesmas and Supporting Puskesmas) Poor people health services Development of online Health Information System Education and capacity building for Drugstores Quality control for health provision Standardisation for health services Prevention of communicable diseases Healthy environment development
Public Works	Increasing the service capacity and scope of clean water Drainage system improvement	Provision and management of water spring Development, improvement, and rehabilitation of drainage system Flood control Rehabilitation of <i>bronjong</i> Development of roads and bridges information system River, Lake, and Water resources management Improvement of drinking water and sewerage management
Housing	Improving the construction of housing	Housing and settlement development Healthy housing development program
Spatial plan	Improving spatial planning, utilisation, and monitoring	Spatial plan Spatial utilisation Spatial control and monitor
Development plan	Improving development plan and institutional capacity	Data and information development Development plan for strategic area Development plan for disaster prone area
Environmental	Preserving mangrove Developing environmental control mechanism	Development of environmental degradation control system Ocean and coastal management and rehabilitation
Coastal and Fisheries	Improving fisherman capacity and expertise Improving the capacity of financial instructions for fisheries sector Law enforcement for regulation that related with coastal and fisheries resources	Fisheries management optimization Fisheries infrastructure development Fisheries intensification, extension, and diversification

Source: Summarized from Tarakan City RPJM 2010 – 2014, p.78 – 84

Aside from the sectoral development policy and programme, Tarakan City RPJM also addresses ten priority programs in chapter 6. Among them there are five programmes directly and indirectly related to the CCRAA. The first two direct programmes are the Optimization of Amal Beach, i.e. for tourism activities that need professional management and infrastructure improvement; and the Development of the Ferry Port, i.e. the development plan of the Ferry Port in North Tarakan to link Tarakan and Toli – toli. As for the three indirect programmes that may be able to enhance the adaptive capacity of Tarakan City, these are the Poverty and Unemployment Mapping, the Optimisation of Zakat, and the Arrangement of the Fisheries Value Chain and Coastal Security.

### 8.1.3 Adaptation Compatibility to Tarakan City RTRW 2010 – 2030

The adaptation compatibility process is being done by summarising the status of Tarakan City's spatial planning documents and measuring how compatible the proposed adaptation strategies can fit into these documents. Current status informs us that Tarakan City Government has enacted its General Spatial Plan (RTRW) and Detailed Spatial Plan (RDTR) for West Tarakan; however the RDTR for East Tarakan, Central Tarakan, and North Tarakan have not been enacted yet.

Compatibility with the RTRW of Tarakan City is done through identification of spatial development programmes located along the coastal area defined in the document. Afterwards, for each programme mentioned, an assessment is done to establish which strategy is suitable according to the adaptation concept. From **Error! Reference source not found.**, it can be seen that almost all of the programmes can be enriched by a related strategy. However, the compatibility also suggests that the initiatives to develop a sea wall and green belt do not necessarily need to be done; hence it only should be developed in specific locations that need protection from a sea wall (hard measurement) or a green belt. In addition, the programme to delineate the coastal areas that have high levels of risk from climate change impact needs to be improved by introducing the ICZM concept; i.e. it can be mainstreamed into the enactment of RDTR for all subdistricts.

Table 8. 6 Compatibility Measurement between RTRW Tarakan City Development Program and Adaptation Strategy in Coastal and Water Sectors

No	Name of Program	Location On Coastal Area	Location Based on Regionalism/Adaptation area		Compatibility With Adaptation Strategy	
			Coastal	Water	Coastal	Water (flood)
1	Improvement of International Airport	Karang Anyar Pantai	West Coast	Area III (Flood)	Accommodation and protection	<ul style="list-style-type: none"> <li>• Installation of Sluice Gate on The River</li> <li>• Levee</li> <li>• Pumping</li> </ul>
2	Improvement of Local Port	Pantai Amal, Tj. Batu (Tarakan Timur), Tj. Pasir (Tarakan Timur)	East Coast		Hard protection	
		Tj. Simaya (Juata Laut), Tj. Selayung (Juata Laut), Tj. Bina-latung (Juata Laut), Juata Laut	West Coast		Accommodation and protection	
3	Improvement of Local Dock	Mamburungan, Tj, Binalatung (Juata Laut)	West Coast		Accommodation and protection	
		Pantai Amal, Tj. Pasir (Tarakan Timur)	East Coast		Hard protection	
4	Improvement of Port Malundung and Tengkeyu	Malundung (Lingkas Ujung), Tengkeyu (Karang Rejo)	West Coast		Accommodation and protection	
5	Area with High Risk due to Climate Change Impact Delineation	Along Tarakan City shoreline	All Area		ICZM	
6	Seawall and Green Belt Development	Along Tarakan City shoreline	All Area		<i>This program should be corrected based on compatibility of each location, and not necessarily need to be developed along the</i>	

No	Name of Program	Location On Coastal Area	Location Based on Regionalism/Adaptation area		Compatibility With Adaptation Strategy	
			Coastal	Water	Coastal	Water (flood)
					<i>shoreline</i>	
7	Development of Fishermen Housing Complex (Slum upgrading, housing in northern area)	Tj. Batu (Tarakan Timur), Tj. Pasir (Tarakan Timur),	East Coast		Coastal Setback	
		Mamburungan	West Coast		Accommodation and protection	
8	Development of market and services facilities	Juata Laut	North Coast	Area I,II, and III (Flood)	Accommodation and protection	<ul style="list-style-type: none"> <li>• Integrated Water Resources Management (IWRM)</li> <li>• The Restoring of the river function and Retention Pond</li> <li>• Installation of Sluice Gate on The River</li> <li>• Levee</li> <li>• Pumping</li> </ul>
		Pamusian, Karang Harapan, Sebengkok, Lingkas Ujung, Karang Rejo, Mamburungan, Kampung Empat, Juata Permai	West Coast		Accommodation and protection	
9	Development of Warehouse	Tanjung Selayung (Juata Laut)	North Coast	Area II (Flood)	Accommodation and protection	<ul style="list-style-type: none"> <li>• Integrated Water Resources Management (IWRM)</li> <li>• The Restoring of the river function and Retention Pond</li> </ul>
		Juata Permai, Mamburungan, Lingkas Ujung, Gunung Lingkas	West Coast	Area III (Flood)	Accommodation and protection	<ul style="list-style-type: none"> <li>• Installation of Sluice Gate on The River</li> <li>• Levee</li> <li>• Pumping</li> </ul>
10	Development of Timber Industry	Juata Permai, Kampung Empat, Mamburungan	West Coast		Accommodation and protection	
11	Development of Shrimp Industry	Tanjung Selayung (Juata Laut)	North Coast		Accommodation and protection	
		Pantai Amal	East Coast		Coastal Setback	
		Mamburungan	West Coast		Accommodation and protection	
12	Development of small and medium industry	Juata Permai, Mamburungan	West Coast	Area I,II, and III (Flood)	Accommodation and protection	<ul style="list-style-type: none"> <li>• Integrated Water Resources Management (IWRM)</li> <li>• The Restoring of the river function and Retention Pond</li> <li>• Installation of Sluice Gate on The River</li> <li>• Levee</li> <li>• Pumping</li> </ul>
		Juata Laut	North Coast		Accommodation and protection	
13	Development of fisheries area (Minapolitan)	Pantai Amal	East Coast	Area I (Flood)	Coastal Setback	<ul style="list-style-type: none"> <li>• Integrated Water Resources Management (IWRM)</li> <li>• The Restoring of the river function</li> </ul>
		Juata Laut	North Coast		Accommodation and protection	
		Mamburungan	West Coast		Accommodation and protection	
14	Development of Defense and Security Strategic Area	Mamburungan, East Mamburungan	West Coast	Area I,II, and III (Flood)	Accommodation and protection	<ul style="list-style-type: none"> <li>• Integrated Water Resources Management (IWRM)</li> </ul>

No	Name of Program	Location On Coastal Area	Location Based on Regionalism/Adaptation area		Compatibility With Adaptation Strategy	
			Coastal	Water	Coastal	Water (flood)
						<ul style="list-style-type: none"> <li>• The Restoring of the river function and Retention Pond</li> <li>• Installation of Sluice Gate on The River</li> <li>• Levee</li> <li>• Pumping</li> </ul>
15	Development of revetment	Pantai Amal	East Coast		Hard protection	
16	Development of protection structure from abration	East Tarakan	East Coast		Hard protection	
17	Protection of mangrove	Mamburungan, Pamusian, Karang Anyar Pantai, Karang Harapan, Juara Permai	West Coast		Mangrove Restoration	
		Juata Laut, Kampung Satu Skip	North Coast		Coastal Forest Restoration	
18	Development of residential area (low, moderate, and high density)			Area I, II, and III (Flood)		<ul style="list-style-type: none"> <li>• Integrated Water Resources Management (IWRM)</li> <li>• The Restoring of the river function and Retention Pond</li> <li>• Installation of Sluice Gate on The River</li> <li>• Levee</li> <li>• Pumping</li> </ul>

Compatibility assessment also provides several suggestions from the adaptation perspective for preparation of RDTR enactment in Tarakan City. As a coastal city, in general, the concept of ICZM should be looked on as a main consideration in developing the detailed plan. However, implementation of ICZM may be different in each subdistrict since there will be difference in terms of functions, conditions, and main adaptation strategy to be included in the RDTR. The level of the RDTR plan is a detailed one, which is more physically oriented towards implementation than the general plan given by RTRW; i.e. contains regulation over zoning, building envelope, and may guide technical specification of spatial allocation. It should be noted that by considering the adaptation concept proposed in this study, the RDTR must consider an adaptation strategy based on its regionalism putting emphasis on functionality which enriches the substance of the RDTR itself. Details of compatibility for each RDTR are given in Table 7.5 Coastal Sector Report.

## 8.2 Compatibility Process

One of the methods for mainstreaming is by measuring the compatibility between preferred adaptation options with the local government programmes. The idea is to see whether the adaptation options fit into programmes that the local government has planned. The tool for this method is the compatibility matrix. It compares adaptation options side by side with government programmes along with its location and risk level. The compatibility assessment will recommend which adaptation

options to be mainstreamed and where to mainstream them into the appropriate plans.

Complete results of the compatibility process for all sectors are attached in the Appendix, while examples of them are shown in the following sections.

### **8.2.1 Example in Coastal Sector**

In the Table 8.7 below, it can be seen that basically there is no compatibility between the adaptation option of accommodation – protection proposed by the expert - with the local government programme, due to the inavailability of programme in 2012 in addressing such options. Therefore, the further recommendation is to have a comprehensive and integrated slum coastal area improvement programme by considering people's livelihood, accessibility, security, and safety aspects. Moreover, the fact that the Building-Code and Environment Plan (RTBL) 2010 exists, it can be continued to serve as a settlement improvement programme for Selumit Pantai and Juara Laut fishing settlements. For further mainstreaming, the Central Government's "Disaster-resilient Village" programme from the Ministry of Marine and Fishery Affairs (KKP) could be an appropriate opportunity, as well as related programmes from the Housing Ministry and Public Works Ministry.



Table 8. 7 Example of Compatibility in Coastal Sector of Tarakan City

No	Hazard and Vulnerability Factor	Expert's Adaptation Option Type	Adaptation Preferred by Expert	Program 2012 (RKP, APBD)	Level of Compatibility	Locations with High and Very-high Level of Risk	Program Location	Location Compatibility Level	Recommendation	Mainstreaming
1	Dense settlement area,  Vital Infrastructure	Accommodation – Protection	Alleviation of housing and building as a means for coastal flood proofing	---	Not Compatible	<u>North</u> : Juata Laut (Northern part of coastal area) <u>East</u> : Lingkas Ujung <u>Central</u> : Selumit Pantai, Sebengkok, Pamusian <u>West</u> : Karang Rejo, Karang Anyar Pantai, Karang Harapan (Western part of coastal area)	---	---	Comprehensive and Integrated Slum area improvement, by considering: - Livelihood, accessibility, security, and safety aspects. - Support continuation of Program in 2010 (RTBL 2010), about resettlement of Selumit Pantai area and Juata Laut fisherman area	<ul style="list-style-type: none"> <li>• Program from KKP: "Disaster Resilient Village"</li> <li>• Program from Housing Ministry (Kemenpera)</li> <li>• Program from Ministry of Public Work (Kementerian PU - Cipta Karya)</li> </ul>

### **8.2.2 Example in Water Sector**

As for an example in the water sector, a compatibility programme for the flood hazard is presented in Table 8.8 below. For Zone 2, the adaptation option of revitalising the river and pond is compatible with the existence of a rehabilitation and normalisation of rivers programme in 2012. However, the adaptation of Integrated Water Resource Management (IWRM) has basically not found its compatible programme. Furthermore, the recommendation for Zone 2 is that there is a necessity for defining the level of priority based on the locations with a high-level of risk and to monitor the effort in the identified locations which are already being developed. On the other hand, for Zone 3, the adaptation by the expert is the installation of a sluice gate, levee, and pumping. The adaptation found its compatibility in several programmes in the 2012 agenda; i.e. river normalisation, river rehabilitation and normalisation, construction of drainage, coordination of a Clean River Programme (Prokasih), and river dredging. However, even though it is compatible, there is no indication about the level of priority for each programme. Therefore the recommendation is to define levels of priority based on the locations with a high level of risk and to monitor the effort in the identified locations which are already being developed.

## Flood Hazard

Table 8. 8 Example of Compatibility in Water Sector of Tarakan City

Zone	Location with High and Very-High Level of Risk (Watershed)	Expert's Preferred Option	Program 2012 (RKP, APBD)	Level of Compatibility	Program Location	Vulnerability Factor	Location Compatibility Level	Recommendation	Mainstreaming
2	Three main watershed, i.e.: a. Semunti (Upstream : Juata Kerikil, Downstream: Juata Laut), b. Bengawan (Upstream : Juata Kerikil, Downstream : Juata Permai) dan c. Persemaian (Upstream : Kampung Satu Sekip, Tengah : Juata Kerikil, Downstream : Karang Harapan)	<ul style="list-style-type: none"> <li>▪ Integrated Water Resource Management (IWRM)</li> <li>▪ Revitalization of river and pond's functions</li> </ul>	Rehabilitation and normalization of river.	Compatible, but not equipped with level of priority	<i>Preserved drainage location</i>	Population density		<ul style="list-style-type: none"> <li>• Priority needs to be addressed for location with high-level of risk</li> <li>• Monitoring of locations which are already being developed, to define further actions where needed.</li> </ul>	
3	Four main watershed, i.e.: a. Sesanip (Upstream : Karang Anyar, Juata Kerikil, Downstream : Karang anyar Pantai), b. Kampung Bugis (Upstream : Kampung Satu Sekip, Tengah : Karang Anyar, Downstream : Karang Anyar Pantai, Karang Balik, Selumit, Selumit Pantai, Karang Rejo), c. Pamusian (Upstream : Kampung Satu Sekip, Tengah : Pamusian, Kampung Empat, Upstream : Sebengkok, Gunung Lingkas, Lingkas Ujung, Mamburungan) d. Karangan (Upstream : Mamburungan Timur, Downstream : mamburungan)	<ul style="list-style-type: none"> <li>▪ Instalation of sluice gate, levee, and pumping.</li> </ul>	River normalization River rehabilitation and normalization Construction of drainage. Coordination of Prokasih/ Superkasih Improvement and river dredging	Compatible, but not equipped with level of priority	Channel in Karang Anyar River All Tarakan <ul style="list-style-type: none"> <li>▪ Sebengkok river</li> <li>▪ Channel in RT 64 Karang Anyar (Kawasan Brimob)</li> <li>▪ Drainage in Juata lembah Karang Harapan</li> <li>▪ Drainage from RT 22 to Pasar Tenguyun,</li> <li>▪ Drainage in RT 13 Kelurahan Pamusian,</li> <li>▪ Drainage in Sungai Pamusian, RT 12, Pamusian,</li> <li>▪ Drainage in Sandiman,</li> <li>▪ Drainage in RT 04,</li> <li>▪ Ditch Kr. Harapan</li> </ul> 3 (tiga) sungai yang BAIS di Kota Tarakan Kanal/DAS mulawarman	Population density		<ul style="list-style-type: none"> <li>• Priority needs to be addressed for location with high-level of risk</li> <li>• Monitoring of locations which are already being developed, to define further actions where needed.</li> </ul>	

### **8.2.3 Example in Health Sector**

Compatibility measurement for health sector is illustrated in Table 8.9 below. In the case of DHF, five adaptations have been proposed by Expert compared with three programmes from the local government in 2012. As a result, basically all of the five are compatible, even though for surveillance and eradication of mosquito breeding sites there are some conditions which indicate the necessity for further adjustment. In terms of adaptation actions and the programme's location, basically it was incompatible since the government programme did not clearly identify the location; thus as a recommendation the merged adaptation programme should basically be implemented in locations with a relatively high level of risk. Finally, the compatibility analysis suggests several mainstreaming possibilities; i.e. additional support of General Allocation Fund/Specific Allocation Fund (DAU/DAK), support from Health Ministry, support from CSR, and integration into the local government's programme in 2013.

## DHF Disease Hazard

Table 8. 9 Example of Compatibility in Health Sector of Tarakan City

No	Hazard and Vulnerability Factor	Expert's Adaptation Option Type	Adaptation Preferred by Expert	Program 2012 (RKP, APBD)	Level of Compatibility	Locations with High and Very-high Level of Risk	Program Location	Location Compatibility Level	Recommendation	Mainstreaming
1	Climate factor impact to hazard (increased temperature, precipitation)	1. Vector-disease control (based on climate change information)	Epidemiologic observations (based on case reports)	<ul style="list-style-type: none"> <li>• <a href="#">Community Health Improvement Program</a> (Implementation of prevention and control for communicable diseases and outbreaks)</li> <li>• <a href="#">Communicable Disease Prevention Program</a> (mosquito fogging, prevention and of infectious diseases, increase epidemiologic surveillance and outbreak response) (Health Agency)</li> </ul>	Compatible	<ul style="list-style-type: none"> <li>• <u>East</u>: Lingkas Ujung (2030)</li> <li>• <u>Central</u>: Selumit Pantai, , Sebangkok (2030), Selumit (Existing, 2030)</li> <li>• <u>West</u>: Karang Rejo, Karang Balik, Karang Anyar Pantai (2030)</li> <li>• <u>North</u>: Juata Permai, Juata Laut (2030)</li> </ul>	---	Incompatible	---	
2			Vector surveillance (larva observation) DHF (Index measures the density of mosquitoes) regular (monthly, bi-weekly, weekly) in each village by a field entomologist ( <a href="#">Jumantik Plus</a> )		Surveillance for DHF vector is not routine due to limitation of budget		---	Incompatible	Capacity building for Jumantik (Optimization of Pokjanel DBD) <ul style="list-style-type: none"> <li>• Increasing number and quality of Jumantik</li> <li>• Enactment of regulation in data validity monitoring</li> </ul>	<ul style="list-style-type: none"> <li>• Support DAU/DAK<sup>7</sup></li> <li>• Support through Health Ministry (Kemenkes)</li> <li>• CSR for health and environment</li> </ul>
3			Eradication of the source of mosquito with routine 3M Plus and PSM.		Compatible, but the time-frame do not consider the historical data of epidemiology		---	Incompatible	Intensification of activities: <ul style="list-style-type: none"> <li>• Accordance to historical data of epidemiology</li> <li>• Accordance to DHF early warning system</li> <li>• Held in location with high-level of risk</li> </ul>	Program 2013
5			Spraying is only based on the indication (result of surveillance and /or incidence of disease / outbreak)		Compatible		---	Incompatible	Control in the implementation of fogging accordance to the instruction of Governor	Program 2013
			<ul style="list-style-type: none"> <li>• Climate factor</li> <li>• Population number and density</li> <li>• Breeding site of mosquito in water vessel</li> </ul>		2. Environmental improvement		Improvement in the capacity of piped clean water network (PDAM)	<a href="#">Development Program for irrigation and water network</a> (Development of clean water network) (DPU – TR)	Compatible	---

<sup>7</sup> Ibid.

### 8.3 Synchronisation Process

The purpose of synchronisation of recommended programmes or activities by local government and programmes or activities that central government agencies have is to identify potential funding mechanisms for those recommended programmes or activities, either available from the sectoral ministries or other sources. The appropriate central government office that manages similar programmes or activities is also identified during the synchronisation process. The result of this synchronisation process for each sector is in the form of a policy matrix as illustrated below.

Complete results of the synchronisation process for all sectors are attached in the Appendix, while examples of them are shown in the following sections.

#### 8.3.1 Example in Coastal Sector

Given the risk of flooding and inundation in coastal areas, the expert tended to suggest an accommodation – protection approach. According to the compatibility matrix, as this adaptation option was not compatible with any of the programmes in the RKPD, the stakeholders in Tarakan City proposed it to be a new programme entitled the comprehensive and integrated slum coastal area improvement programme. The leading agency for this adaptation programme is the Public Works Agency, in which the national stakeholders are the Ministry of Public Works, Ministry of Housing and Ministry of Marine and Fisheries Affairs..

Table 8. 10 Example of Synchronization Result in Coastal Sector of Tarakan City

Risk	Expert's Option	No	Development Program related with Climate Change Adaptation	Responsible Agency	National Stakeholders
Flooding in coastal area	Accommodation – Protection	1	Comprehensive and Integrated Slum Coastal Area improvement	DPUTR	Kemen-PU DJCK; Kemenpera Kemen-KP DJKP3K
			1.1 Alleviation of building		

#### 8.3.2 Example in Water Sector

Due to the risk of flooding, the expert basically emphasizes a river normalisation approach (see Table 8.11 below). In this respect, it has compatibility with seven governmental programmes. The leading agency for these synchronised adaptation programmes is the Public Works Agency, in which the national stakeholder is the Ministry of Public Works- Directorate General of the Water Resources.

Table 8. 11 Example of Synchronization Result in Water Sector of Tarakan City

Risk	Expert's Option	No	Development Program related with Climate Change Adaptation	Responsible Agency	Stakeholders
Flood	River Normalization	3	Integrated Water Resource Management	Dinas PU-TR	Kemen PU DJSDA
			3.1 Rehabilitation and Normalization of River		
			3.2 Revitalization of River and Pond's Function		
		4	River Normalization Program	Dinas PU-TR	Kemen PU DJSDA
			4.1 Rehabilitation and Normalization of		

			River		
		4.2	Construction of drainage		
		4.3	Coordination of Prokasih/Superkasih Program		
		4.4	River dredging program		
		4.5	Installation of river sluice, levee, and pumping		

### 8.3.3 Example in Health Sector

In the health sector, synchronisations of adaptation and the government's programme were being done for all type of diseases. For DHF (see Table 8.12 below), two of the Expert's main approaches, i.e. vector control and environmental improvement, were synchronised into five government programmes; with the responsible agencies being the Health Agency of Tarakan City and the Port Health Office of the Ministry of Health. The related national stakeholder is the Health Ministry - Directorate General of Disease Eradication and Environmental Health.

One development programme will take place which is an adaptation action in the form of an environmental improvement; which will be led by the Public Works Agency, so that the related national stakeholder is the Ministry of Public Works - Directorate General of Cipta Karya.

Table 8. 12 Example of Synchronisation Result in Health Sector of Tarakan City

Risk	Expert's Option	No	Development Program related with Climate Change Adaptation	Responsible Agency	Stakeholders	
DHF	Vector Control	1	Disease Prevention Program	1. Dinas Kesehatan; 2. Kemenkes-Kantor Kesehatan Pelabuhan	Kemenkes DJ-P2PL	
			Linked with: Communiith Health Improvement Program			
		1,1	Fogging		1. Kemenkes Dir. PPBB Vektor; 2. Kemenkes-Kantor Kesehatan Pelabuhan	
		1,2	Communicable disease prevention services		Kemenkes Arbovirosis	
		1,3	Peningkatan surveilans epidemiologi dan penanggulangan wabah		Kemenkes Simkarkesmas	
		1,4	DHF vector surveillance in each village by field entomologist		Kemenkes Arbovirosis, Simkarkesmas	
	1,5	Eradication of mosquito breeding site by routine 3M Plus and PSN Program				
	Environmental Improvement	4	Development and construction of irrigation and other water networks		Dinas PU Tata Ruang; PDAM	Kemen-PU DJCK
			4,1	Construction of clean water network		
2,1			Construction of clean water network			

### 8.3 Champion Programme

Finally, the champion programme is formulated based on the recommendations of the adaptation prioritisation process as well as the synchronisation in order to obtain a funding commitment either from state budget, through respective central government agencies, or from non-state budget, including international funds. This champion programme is actually multi-sectoral, but the associated sectoral programmes and activities are identified, as illustrated in the table below. The leading agency from central government is also identified for every programme being

proposed. The table also lists which risk is to be anticipated by the programme or activities, as well as the dominant vulnerability factor, in order to sustain the flow that all programmes or activities are addressing climate change impacts as the results of CCRAA.

Table 8. 13 Champion Program of Tarakan City

Champion Program	Related Sector in CCRAA	Related Governmental Program	Related Activities	Related Ministry / Agency	Climate Change Risk Anticipation	Dominant Vulnerability Factor
Comprehensive and Integrated Slum Improvement Program in Coastal area of Tarakan	Coastal	Coastal-slum improvement program	<ul style="list-style-type: none"> <li>Detailed topography, coastal line, and building height in coastal area surveys</li> <li>Building alleviation</li> </ul>	Kemen-Pera; Kemen-KP DJKP3K; Kemen-PU DJCK	Coastal inundation	<ul style="list-style-type: none"> <li>Highly-dense population with low level of social-economy; which increases the rate of communicable diseases, e.g. DHF and diarrhea</li> <li>Declivous coastal slope which retains inundation period from seawater, rain, and river-water; which increases the risk of DHF and malaria.</li> <li>Existence of extensive infrastructural developments; e.g. airport, fisheries industry.</li> </ul>
	Water	River Normalization Program	<ul style="list-style-type: none"> <li>River rehabilitation and normalization</li> <li>River dredging program</li> </ul>	Kemen-PU DJSDA	Flood	
	Health	Communicable Disease Prevention Program	<ul style="list-style-type: none"> <li>Fogging</li> <li>Eradication of mosquito breeding site (PSN) and routine 3M Plur Program</li> <li>Pelayanan pencegahan dan penanggulangan penyakit menular</li> </ul>	Kemenkes DJP2PL	<ul style="list-style-type: none"> <li>DHF</li> <li>Malaria</li> </ul>	
		Irrigation and other water network development program	Construction of clean and drink water network (PDAM)	Kemen-PU DJCK	<ul style="list-style-type: none"> <li>DHF</li> <li>Diarrhea</li> </ul>	
Climate-related Inventarisation and standarization Program.	Supporting Scientific Data	Climate-related Inventarisation and standarisasi Program.	<ul style="list-style-type: none"> <li>Climate-data standardization</li> <li>Coastal-data standardization</li> <li>Climate-data inventarisation</li> <li>Coastal-data inventarisation</li> </ul>	BMKG; Badan Informasi Geospasial; Kemen-Ristek LIPI LAPAN	All sectoral risks	Low level of accuracy in climate change and its projection analysis might lead to inappropriate adaptation recommendation; i.e. due to the lack and bad quality of data.





## References

- Abdurachman, O., B. Setiawan, N. Puspita, M.I. Ikhwan, E. Riawan. *Climate Risk and Adaptation Assessment of Water Sector in the Tarakan City*. Final Report of Climate Change Risk and Adaptation of Tarakan City. AusAID, GIZ, City Government of Tarakan, June 2011.
- Hadi, T.W., I.G. Junnaedhi, M.R. Syahputra, 2011. *Climate Analysis and Projections in Tarakan*. Final Report of Climate Change Risk and Adaptation of Tarakan City. AusAID, GIZ, City Government of Tarakan, June 2011
- Latief, H., H. Sunendar, D.O. Ismoyo, A. Danoesobroto, M.S. Fitriyanto, M.B.F. Bisri, 2011. *Climate Risk and Adaptation Assessment of Coastal Sector in the Tarakan City of East Kalimantan Province*. Final Report of Climate Change Risk and Adaptation of Tarakan City. AusAID, GIZ, City Government of Tarakan, June 2011.
- Sofian, 2011. *Sea Level Rise and Extreme Event Projections: Case Study Tarakan*. Final Report of Climate Change Risk and Adaptation of Tarakan City. AusAID, GIZ, City Government of Tarakan, May 2011.
- Sofyan, A., R. Agoes, 2011. *Risk And Adaptation Assessment On Health Sector In Tarakan*. Final Report of Climate Change Risk and Adaptation of Tarakan City. AusAID, GIZ, City Government of Tarakan, June 2011.



## Appendix

## A.1 Compatibility Matrices

### A.1.1 Coastal Sector

No	Faktor bahaya, kerentanan	Tipe opsi adaptasi expert	Pilihan adaptasi expert	Program 2012 (RKP, APBD)	Tingkat kesesuaian program	Lokasi yang beresiko tinggi dan sangat tinggi	Lokasi Program	Tingkat kesesuaian lokasi	Rekomendasi	Main-streaming
1	Pemukiman padat, Infra-struktur vital	Akomodasi - Proteksi	<i>Building level adjustment (menaikkan level lantai rumah dan bangunan) sebagai coastal flood proofing (pelindung banjir pantai)</i>	---	Tidak ada yang sesuai	Utara: Juata Laut (Region Pesisir Utara) Timur: Lingkas Ujung Pantai, Sebengkok, Pamusian Barat: Karang Rejo, Karang Anyar Pantai, Karang Harapan (Region Pesisir Barat)	---	---	Program pena-taan kawasan perkampungan kumuh pesisir secara kompre-hensif & terintegrasi: -memperhati-kan aspek mata penca-harian, aksesibi-litas, kea-manan, dan keselamatan -melanjutkan Program 2010 (Sudah ada RTBL 2010 tlg. Penataan: ✓ Kawasan Selumit pantai ✓ Kawasan nelayan Juata Laut	<ul style="list-style-type: none"> <li>• Program KKP: "Desa Tahan Bencana"</li> <li>• Kementerian Pe-rumahan Rakyat</li> <li>• Kementerian PU (Cipta Karya)</li> </ul>
2	Infra-struktur tambak		<i>Fishpond level adjustment (menaikkan level tanggul/pematang tambak) sebagai coastal flood proofing</i>	---	Tidak ada yang sesuai	Barat: Karang Rejo, Karang Anyar Pantai, Karang Harapan (Region Pesisir Barat)	---	---	Program penataan kawasan tambak (untuk bahan diskusi lebih lanjut)	Program KKP: "Desa Tahan Bencana"
3	Pemukiman padat, Infra-struktur vital		<i>Coastal flood proofing (pelindung banjir pantai)</i>	Program pengendalian banjir: Peningkatan pembersihan dan pengerukan sungai/kali (DPUTR dan DKPP)	Sesuai	Tengah: Selumit Pantai, Sebengkok, Pamusian Barat: Karang Rejo, Karang Anyar Pantai, Karang Harapan (Region Pesisir Barat)	Sungai Pamusian	Sesuai (lokasi yang beresiko tinggi adalah DAS Pamusian)	Dilaksanakan setiap tahun	Program tahun 2013 dan seterusnya

No	Faktor bahaya, kerentanan	Tipe opsi adaptasi expert	Pilihan adaptasi expert	Program 2012 (RKP, APBD)	Tingkat kesesuaian program	Lokasi yang beresiko tinggi dan sangat tinggi	Lokasi Program	Tingkat kesesuaian lokasi	Rekomendasi	Main-streaming
4	Rendaman pesisir dari sungai	Akomodasi di daerah estuari	<i>Flood proofing</i> (pelindung banjir)		Sesuai	Timur: Gunung Lingkas, Kampung Empat (Region Pesisir Barat)	DAS Mularman	Sesuai	Dilaksanakan setiap tahun	Program tahun 2013 dan seterusnya
5	Infrastruktur vital; gelombang tinggi	Proteksi keras pada lokasi tertentu	<i>Sea wall</i> (tembok pantai, <i>revetment</i> )	Program pengendalian banjir: Pembangunan prasarana pengaman pantai – Terbangunnya bangunan pengaman pantai (DPUTR)	Sesuai dengan Nama Kegiatan	Timur: Lingkas Ujung, Mamburungan, Pantai Amal Tengah: Kampung 1 Skip (Region Pesisir Timur)	Pantai Amal Baru – Binalatung	Masih ada yang belum sesuai	<ul style="list-style-type: none"> <li>• Perlu menambah lokasi kegiatan</li> <li>• Struktur dan penataan bangunan perlu memperhatikan aspek lingkungan</li> </ul>	Program tahun 2013
6	Infrastruktur vital; gelombang tinggi, abrasi tinggi		<i>Jetty</i> (penahan abrasi), <i>breakwater</i> (alat pemecah ombak)	Program pengendalian banjir: Pembangunan prasarana pengaman pantai – Terbangunnya bangunan penahan abrasi pantai (DPUTR)	Sesuai dengan Nama Kegiatan	Timur: Mamburungan, Pantai Amal Tengah: Kampung 1 Skip (Region Pesisir Timur)	Pantai Amal Baru – Binalatung	Masih ada yang belum sesuai		Program tahun 2013
7	Infrastruktur wisata pantai	Proteksi lunak	Restorasi hutan pantai (mangrove dan pinus pantai)	Pengembangan dan Pemantapan Kawasan Konservasi Laut, Suaka Perikanan, dan Keanekaragaman Hayati Laut: 1. Sosialisasi Pelestarian Pohon 2. Penanaman Pohon Endemik Tarakan (?) (BPLH)	(tidak sesuai?)	Utara: Juata Laut (Region Pesisir Utara) Timur: Mamburungan, Pantai Amal Tengah: Kampung 1 Skip (Region Pesisir Timur)	---	---	Program Restorasi Mangrove dan Hutan Pantai (melihat ketersediaan lahan dan jenis vegetasi)	<ul style="list-style-type: none"> <li>• Kementerian Kehutanan</li> <li>• KKP</li> </ul>
8	Ketersediaan mangrove		Restorasi mangrove		(tidak sesuai?)	Timur: Lingkas Ujung Barat: Karang Rejo, Karang Anyar Pantai, Karang Harapan Utara: Juata Permai (Region Pesisir Barat)	---	---		
9	Ketersediaan pasir pantai		<i>Sand dune</i> (gosong pasir)	---	Tidak ada yang sesuai	Timur: Mamburungan, Pantai Amal Tengah: Kampung 1 Skip (Region Pesisir Timur)	---	---		

No	Faktor bahaya, kerentanan	Tipe opsi adaptasi expert	Pilihan adaptasi expert	Program 2012 (RKP, APBD)	Tingkat kesesuaian program	Lokasi yang beresiko tinggi dan sangat tinggi	Lokasi Program	Tingkat kesesuaian lokasi	Rekomendasi	Main-streaming
10	Pemukiman padat, infrastruktur vital	<i>Integrated coastal zone management (ICZM)</i> (Pengelolaan pesisir terintegrasi)	<i>Managed realignment</i> (pengelolaan garis pantai) dengan <i>beach nourishment</i> (pengisian ulang pasir pantai) dan penataan ulang kawasan pesisir <u>Catatan:</u> Opsi proteksi dengan revetment di Pantai Amal yang sudah dilaksanakan juga termasuk di dalam ICZM ini.	<ul style="list-style-type: none"> <li>Program Perencanaan Tata Ruang: Penyusunan RDTRK Tarakan Utara, Timur, Tengah; Sosialisasi RTRW Kota Tarakan (DPUTR)</li> <li>Program pengembangan wilayah strategis dan cepat tumbuh (DPUTR)</li> <li>Program pengendalian banjir: Pembangunan prasarana pengaman pantai – Terbangunnya bangunan pengaman pantai (DPUTR)</li> </ul>	Sebagian sesuai ( <i>perlu dicek apakah unsur-unsur ICZM dan opsi proteksi pesisir sudah masuk dalam RDTRK</i> )	Timur: Mamburungan, Pantai Amal Tengah: Kampung 1 Skip (Region Pesisir Timur)	Tarakan Utara, Timur, Tengah Untuk revetment: Pantai Amal Baru – Binalatung	Sesuai	Unsur-unsur ICZM dan opsi proteksi pesisir perlu diperhatikan dalam RDTRK dan Sosialisasi RTRW	
11	Pemukiman padat, infrastruktur vital		<i>Coastal setback</i> (penarikan kawasan rumah, sarana, dan prasarana menjauhi garis pantai)	---	Tidak ada yang sesuai		---	---	Relokasi – mundur dari garis pantai bisa diperhatikan dalam RDTRK jika memungkinkan	

## A.1.2 Water Sector

### a. Water Shortage Hazard

Zona	Lokasi VHR, HR (DAS)	Opsi expert	Program 2012 (RKP, APBD)	Tingkat kesesuaian program	Lokasi Program	Faktor Dominan Kerentanan	Tingkat kesesuaian lokasi	Rekomendasi	Main-streaming
1	Tarakan Barat: Kel. Karang Anyar, Karang Balik, Karang Harapan	<ul style="list-style-type: none"> <li>Optimalisasi penyediaan air dari PDAM untuk Sub Zona 1A</li> <li>Untuk Sub Zona 1B, optimasi penyediaan air sebagian dari PDAM dan lainnya dengan pemanfaatan air tanah tertekan (kedalaman rata-rata: 96,8 m)</li> </ul>	Peningkatan pelayanan air bersih kepada pelanggan	Sesuai	---	<ul style="list-style-type: none"> <li>Peningkatan permintaan air oleh dan kapasitas reservoir terpasang</li> </ul>	Belum diketahui	<ul style="list-style-type: none"> <li>Evaluasi kebutuhan embung di masa mendatang</li> <li>Perlu adanya kejelasan mengenai lokasi dari rencana pengembangan penyediaan kebutuhan air bersih.</li> </ul>	
2	Tarakan Utara, DAS Bengawan (Hulu : Kel. Juata Kerikil, Hilir : Kel. Juata Permai)	<ul style="list-style-type: none"> <li>Pengembangan IPAs baru, memanfaatkan DAS Bengawan dan Semunti dengan potensi debit 0,60 m<sup>3</sup>/dtk atau 18,932 jt m<sup>3</sup>/th</li> <li>Pengembangan reservoir untuk melengkapi IPAs baru</li> <li>Pemanfaatan air tanah dari lapisan akuifer yang terletak 130 m di bawah permukaan tanah</li> </ul>	Peningkatan pelayanan air bersih kepada pelanggan	Sesuai	---	<ul style="list-style-type: none"> <li>Peningkatan permintaan air bersih oleh</li> <li>Belum adanya pemanfaatan DAS yang memiliki potensi SDA</li> </ul>	Belum diketahui	<ul style="list-style-type: none"> <li>Evaluasi kebutuhan embung di masa mendatang <u>terutama dengan adanya rencana pengembangan untuk pemukiman</u></li> <li>Perlu adanya kejelasan mengenai lokasi dari rencana pengembangan penyediaan kebutuhan air bersih.</li> </ul>	
3	Sungai Mangantai (Hulu : Kel. Kampung Satu Sekip, Hilir : Kel. Juata)	<ul style="list-style-type: none"> <li>Pemanfaatan air permukaan lebih disarankan untuk Zona 3A dan 3B, Pembangunan reservoir di Sungai Mangantai untuk Sub Zona 3A</li> <li>Pengembangan reservoir untuk Sub Zona 3B DAS B</li> </ul>	Peningkatan pelayanan air bersih kepada pelanggan	Sesuai	---	<ul style="list-style-type: none"> <li>Permintaan air meningkat oleh industri, jasa dan permukiman, serta pariwisata</li> <li>Potensi air permukaan yang tidak cukup besar</li> </ul>	Belum diketahui	<ul style="list-style-type: none"> <li>Evaluasi kebutuhan embung di masa mendatang, <u>terutama dengan adanya rencana pengembangan untuk industri.</u></li> <li>Perlu adanya kejelasan mengenai lokasi dari rencana pengembangan penyediaan kebutuhan air bersih.</li> </ul>	
4	Tarakan Timur (Hulu: Kampung Satu Sekip, Tengah : Kampung Enam, Hilir : Pantai Amal)	<ul style="list-style-type: none"> <li>Optimalisasi IPA Binalatung untuk Sub Zona 4A</li> <li>Panen air hujan serta alternatif lain seperti pemanfaatan air tanah dangkal, desalinasi, atau panen air hujan untuk Sub Zona 4B</li> </ul>	DED Tampung Air Baku Tarakan Timur	Sesuai	Tarakan Timur	<ul style="list-style-type: none"> <li>Debit sungai air Binalatung yang cukup besar berpotensi menjadi ancaman terhadap jaringan perpipaan</li> </ul>	Belum diketahui	<ul style="list-style-type: none"> <li>Evaluasi kebutuhan embung di masa mendatang</li> <li>Perlu adanya kejelasan mengenai lokasi dari rencana pengembangan penyediaan kebutuhan air bersih.</li> </ul>	



Zona	Lokasi VHR, HR (DAS)	Opsi expert	Program 2012 (RKP, APBD)	Tingkat kesesuaian program	Lokasi Program	Faktor Dominan Kerentanan	Tingkat kesesuaian lokasi	Rekomendasi	Main-streaming
5		<ul style="list-style-type: none"> <li>Pemanfaatan air tanah</li> <li>Alternatif lain adalah desalinasi air laut dan panen air hujan</li> </ul>			---	<ul style="list-style-type: none"> <li>Proyeksi kebutuhan air meningkat</li> <li>Data potensi air tanah masih minim, namun survey menunjukkan bahwa kualitas potensi air tanah baik</li> </ul>	Belum diketahui		
6	Tarakan Barat	<ul style="list-style-type: none"> <li>Konservasi air permukaan dan air tanah</li> </ul>	<ul style="list-style-type: none"> <li>Pengamanan Hutan</li> <li>Pemagaran hutan</li> <li>Perencanaan dan tata batas kawasan hutan</li> </ul>	Sesuai	---	<ul style="list-style-type: none"> <li>Lokasi merupakan daerah konservasi yang berfungsi pula sebagai kawasan resapan air tanah untuk Tarakan Barat</li> </ul>	Belum diketahui		

## b. Flood Hazard

Zona	Lokasi VHR, HR (DAS)	Opsi expert	Program 2012 (RKP, APBD)	Tingkat kesesuaian program	Lokasi Program	Faktor Dominan Kerentanan	Tingkat kesesuaian lokasi	Rekomendasi	Main-streaming
1	Di sepanjang utara-timur ke selatan-timur Kota Tarakan; meliputi 5 DAS utama, yaitu: a. Maya (Tarakan Utara : Kelurahan Juata), b. Mangantai (Hulu : Kel Kampung Satu Sekip, Hilir : Kel Juata), c. Binalatung (Hulu : Kampung Satu Sekip, Tengah : Kampung Enam, Hilir : Pantai Amal), d. Kuli (Hulu : Kampung Enam, Hilir: Pantai Amal) dan e. Amal Baru (Hulu : Mamburungan Timur dan Kampung Empat, Hilir : Pantai Amal)	<ul style="list-style-type: none"> <li>Manajemen Sumber Daya Air Terpadu (IWRM)</li> <li>Pemulihan Fungsi Sungai</li> </ul>	Program Pembangunan saluran drainase/ gorong-gorong (DPUTR)	Sesuai, tetapi belum ada skala prioritas	<ul style="list-style-type: none"> <li>Saluran P. Banda - Jembatan Keramat</li> <li>Saluran RT 64 Karang Anyar (Kawasan Brimob)</li> <li>Saluran Kusuma Bangsa I (samping Imigrasi - Kusuma Bangsa)</li> </ul>	Kepadatan penduduk	Skala peta belum sama antara opsi expert dengan program	<ul style="list-style-type: none"> <li>Mencari informasi lebih lanjut mengenai ketersediaan Master Plan Drainase. <u>Catatan:</u> Baru ada utk Tarakan Utara)</li> <li>Melanjutkan inventarisasi saluran drainase dari Master Plan yang ada</li> <li>Menyusun Master Plan untuk lokasi-lokasi yang belum ada, khususnya di lokasi yang beresiko tinggi <u>Catatan:</u> Menyusun sistem drainase yang ter-inter-koneksi</li> </ul>	
2	Mencakup 3 DAS utama yaitu d. Semunti (Hulu : Juata Kerikil, Hilir: Juata Laut), e. Bengawan (Hulu : Juata Kerikil,	<ul style="list-style-type: none"> <li>Manajemen Sumber Daya Air Terpadu (IWRM)</li> <li>Pemulihan Fungsi</li> </ul>	Rehabilitasi normalisasi saluran sungai	Sesuai, tetapi belum ada skala prioritas	Terpeliharanya saluran drainase	Kepadatan Penduduk		<ul style="list-style-type: none"> <li>Perlu ada prioritas program sesuai dengan lokasi yang berisiko tinggi</li> <li>Perlu mencari informasi</li> </ul>	

Zona	Lokasi VHR, HR (DAS)	Opsi expert	Program 2012 (RKP, APBD)	Tingkat kesesuaian program	Lokasi Program	Faktor Dominan Kerentanan	Tingkat kesesuaian lokasi	Rekomendasi	Main-streaming
	Hilir : Juata Permai) dan f. Persemaian (Hulu : Kampung Satu Sekip, Tengah : Juata Kerikil, Hilir : Karang Harapan)	Sungai dan Kolam						lebih lanjut tentang lokasi yang sudah ditangani untuk mempermudah upaya yang akan dilakukan	
3	Mencakup 4 DAS utama, yaitu: e. Sesanip (Hulu : Karang Anyar, Juata Kerikil, Hilir : Karang anyar Pantai), f. Kampung Bugis (Hulu : Kampung Satu Sekip, Tengah : Karang Anyar, Hilir : Karang Anyar Pantai, Karang Balik, Selumit, Selumit Pantai, Karang Rejo), g. Pamusian (Hulu : Kampung Satu Sekip, Tengah : Pamusian, Kampung Empat, Hulu : Sebangkok, Gunung Lingkas, Lingkas Ujung, Mamburungan) h. Karungan (Hulu : Mamburungan Timur, Hilir : mamburungan)	<ul style="list-style-type: none"> <li>Pemasangan gerbang pintu air di sungai, tanggul, dan pemompaan.</li> </ul>	Pelaksanaan Normalisasi Sungai Rehabilitasi normalisasi saluran sungai Pembangunan saluran drainase/ gorong-gorong	Sesuai, tetapi belum ada skala prioritas	Saluran S. Karang Anyar Se-Kota Tarakan <ul style="list-style-type: none"> <li>Sungai sebangkok</li> <li>Saluran RT 64 Karang Anyar (Kawasan Brimob)</li> <li>Drainase Juata lembah Karang Harapan</li> <li>Drainase dari RT 22 ke Pasar Tenguyun,</li> <li>Drainase RT 13 Kelurahan Pamusian,</li> <li>Drainase Sungai Pamusian RT 12 Kelurahan Pamusian,</li> <li>Drainase samping rumah Bp. Jalil Sandiman,</li> <li>Drainase RT 04,</li> <li>Parit Kr. Harapan</li> </ul> 3 (tiga) sungai yang BAIS di Kota Tarakan Kanal/DAS mulawarman	Kepadatan Penduduk		<ul style="list-style-type: none"> <li>Perlu ada prioritas program sesuai dengan lokasi yang berisiko tinggi</li> <li>Perlu mencari informasi lebih lanjut tentang lokasi yang sudah ditangani untuk mempermudah upaya yang akan dilakukan</li> </ul>	
			Koordinasi pengelolaan Prokasih/Superkasih						
			Peningkatan pembersihan dan pengerukan sungai/kali						

**c. Landslide Hazard**

Zona	Lokasi VHR, HR (DAS)	Opsi expert	Program 2012 (RKP, APBD)	Tingkat kesesuaian program	Lokasi Program	Faktor Dominan Kerentanan	Tingkat kesesuaian lokasi	Rekomendasi	Mainstreaming
1	Tarakan Timur (Kampung Empat, Mamburungan, Gunung Lingkas, Lingkas Ujung, mamburungan Timur, pantai Amal)	Forestasi	Penghijauan lingkungan (Dishutamben)	Sesuai	Belum ada lokasi secara sistematis	Kepadatan Penduduk	Belum diketahui		
2	Tarakan Timur	Pekerjaan Teknik	---	Belum sesuai			Belum diketahui		
3	Tarakan Tengah (Selumit, Sebengkok, Pamusian, Kampung Satu Sekip)	Drainase	Program pembangunan saluran drainase/Gorong-gorong	Sesuai			Belum diketahui		
4	Tarakan Utara (Juata Permai, Juata Laut) dan Tarakan Barat (Karang Anyar Balik, karang Anyar, Karang Harapan)	<ul style="list-style-type: none"> <li>• Modifikasi geometri lereng</li> <li>• Drainase</li> <li>• Struktur dinding penahan tanah</li> <li>• Perkuatan lereng</li> </ul>	---	Belum sesuai			Belum diketahui		

### A.1.3 Health Sector

#### a. DHF Hazard

No	Faktor bahaya, kerentanan	Tipe opsi adaptasi expert	Opsi adaptasi usulan expert	Rencana Program 2012 (RKP, APBD)	Tingkat kesesuaian program	Lokasi resiko tinggi dan sangat tinggi	Lokasi Program	Tingkat kesesuaian lokasi	Rekomendasi	Main-streaming
1	Faktor terkait dengan faktor bahaya perubahan iklim (peningkatan suhu, curah hujan)	1. Pengendalian vektor penyakit (berdasarkan informasi perubahan iklim)	Pengamatan Epidemiologi (sesuai laporan kasus)	<ul style="list-style-type: none"> <li>• <a href="#">Program Upaya Kesehatan Masyarakat</a> (Penyelenggaraan pencegahan dan penanggulangan penyakit menular dan wabah)</li> <li>• <a href="#">Program Pencegahan dan Penanggulangan Penyakit Menular</a> (penyemprotan fogging nyamuk, pelayanan pencegahan dan penanggulangan penyakit menular, Peningkatan surveilans epidemiologi dan penanggulangan wabah) (Dinas Kesehatan)</li> </ul>	Sudah sesuai	<ul style="list-style-type: none"> <li>• Timur: Lingkas Ujung (2030)</li> <li>• Tengah: Selumit Pantai, , Sebangkok (2030), Selumit (Existing, 2030)</li> <li>• Barat: Karang Rejo, Karang Balik, Karang Anyar Pantai (2030)</li> <li>• Utara: Juata Permai, Juata Laut (2030)</li> </ul>	---	Tidak sesuai	---	
2			Surveillans vektor (pengamatan jentik DBD (mengukur Indeks Kepadatan Nyamuk) rutin (bulanan, 2 mingguan, mingguan) di setiap desa/ kelurahan oleh entomologist lapangan (Jumantik Plus)		Surveillans vektor DBD belum rutin, anggaran terbatas		<ul style="list-style-type: none"> <li>• Peningkatan kemampuan Jumantik (Optimalisasi Pokjanal DBD)</li> <li>• Menambah jumlah dan kualitas Kader Jumantik</li> <li>• Menaikkan insentif yang berbasis kinerja</li> <li>• Peraturan pengawasan tentang validitas data</li> </ul>	<ul style="list-style-type: none"> <li>• Penambahan DAU/ DAK</li> <li>• Kemen-kes</li> <li>• Dana CSR utk. Kesehatan &amp; Lingkungan</li> </ul>		
3			Pemberantasan sumber habitat sarang nyamuk dengan program 3M Plus dan PSN secara rutin		Sudah sesuai tapi <i>timing-nya</i> belum dikaitkan dengan data historis epidemiologi		<ul style="list-style-type: none"> <li>• Kegiatan lebih digalakkan: <ul style="list-style-type: none"> <li>• Sesuai dengan analisis data historis epidemiologi</li> <li>• Sesuai dengan Sistem Peringatan Dini DBD</li> <li>• Lokasi kegiatan terutama di wilayah risiko tinggi</li> </ul> </li> </ul>	Program 2013		
4			Abatisasi dan/atau pemakaian IGR (misal Altosid) di lokasi sarang nyamuk		Sudah sesuai tapi dievaluasi secara berkala		Efektivitas kegiatan abatisasi perlu dievaluasi secara berkala	Mulai dari Program 2013		
5			Penyemprotan hanya atas indikasi (hasil surveilans dan/atau ada kejadian penyakit/KLB)		Sudah sesuai		Pengawasan terhadap pelaksanaan penyemprotan, sesuai dengan SE Gubernur untuk permintaan fogging	Program 2013		
6			Sosialisasi tentang APD (alat pelindung diri) seperti pengusir nyamuk, jaring nyamuk, kelambu celup, semprotan nyamuk, pakaian yg sesuai		Kegiatan sesuai; tapi hasilnya belum maksimal		Penyesuaian <u>strategi sosialisasi</u> agar lebih bisa mengubah perilaku masyarakat (Waktu kegiatan sesuai dengan catatan tersebut di atas)	Program 2013		
7			Sosialisasi tentang alat pelindung rumah misal		Kegiatan sesuai; tapi					

No	Faktor bahaya, kerentanan	Tipe opsi adaptasi expert	Opsi adaptasi usulan expert	Rencana Program 2012 (RKP, APBD)	Tingkat kesesuaian program	Lokasi resiko tinggi dan sangat tinggi	Lokasi Program	Tingkat kesesuaian lokasi	Rekomendasi	Main-streaming
			kawat kasa anti nyamuk di pintu dan jendela)	kesehatan) (Dinas Kesehatan)	hasilnya belum maksimal					
8	Faktor terkait dengan faktor: • Bahaya iklim (peningkatan suhu, curah hujan)	2. Perbaikan lingkungan	Sosialisasi: Mengurangi genangan dan/atau memasukkan musuh biologis/predator (ikan nila, ikan cupang, dsb) pada tempat genangan.	<a href="#">Program Promosi Kesehatan dan Pemberdayaan Masyarakat</a> (idem di atas) (Dinas Kesehatan)	Kegiatan sesuai; tapi hasilnya belum maksimal	• Timur: Lingkas Ujung (2030) • Tengah: Selumit Pantai, Sebangkok (2030), Selumit (Existing, 2030) • Barat: Karang Rejo, Karang Balik, Karang Anyar Pantai (2030) • Utara: Juata Permai, Juata Laut (2030)	---	Tidak sesuai	<ul style="list-style-type: none"> <li>Peraturan tentang Penataan Lingkungan Sehat:               <ul style="list-style-type: none"> <li>SE Walikota/Bupati,</li> <li>Peraturan Walikota/Bupati</li> <li>Perda</li> <li>SK Bersama Menkes, MenLH, Mendagri</li> </ul> </li> <li>Lokasi kegiatan difokuskan pada daerah-daerah beresiko tinggi</li> </ul>	Kemen LH mengkoordinasikan SKB Menkes, MenLH, Mendagri tentang Penataan Lingkungan Sehat-
9	• Jumlah dan kepadatan populasi		Perbaikan saluran drainase/pembuangan air hujan	<a href="#">Program Pembangunan saluran drainase/gorong-gorong</a> (DPUTR)	Sudah sesuai		---	Tidak sesuai		
10	• Potensi sarang nyamuk di bak-bak akibat ketiadaan pipanisasi air minum serta di saluran buangan air hujan		Peningkatan pelayanan air bersih perpipaan (PDAM)	<a href="#">Program pengembangan dan pengelolaan jaringan irigasi, rawa dan jaringan pengairan lainnya</a> (Pembangunan jaringan air bersih/air minum) (DPUTR)	Sudah sesuai		---	Tidak sesuai		
11			Pengendalian nyamuk di dalam perumahan dan bangunan umum, di pekarangan dan sekitarnya	<a href="#">Program Pengembangan Lingkungan Sehat</a> (Dinas Kesehatan)	Kegiatan sesuai; materi belum sesuai dan belum terintegrasi		---	Tidak sesuai		
12	Faktor terkait dengan faktor: • Bahaya iklim (peningkatan suhu, curah hujan)	3. Pengawasan/pengamatan agen penyakit	Monitoring serologi virus DBD secara berkala oleh virologist	---	Belum sesuai		---	Tidak sesuai	Monitoring serologi virus DBD secara berkala 1 tahun sekali oleh virologist	Kemenkes
13	• Fasilitas kesehatan		Pengembangan percobaan vaksin DBD	---	Belum sesuai		---	Tidak sesuai	<ul style="list-style-type: none"> <li>Kerjasama riset vaksin dengan Fak. Kedokteran (FK) Univ. Brawijaya</li> <li>Perlunya keterlibatan RS dalam riset vaksin DBD</li> </ul>	<ul style="list-style-type: none"> <li>Kemen-kes</li> <li>Dikti Kemen-dikbud</li> </ul>

## **b. Malaria Hazard**

No	Faktor bahaya, kerentanan	Tipe opsi adaptasi expert	Opsi adaptasi usulan expert	Rencana Program 2012 (RKP, APBD)	Tingkat kesesuaian program	Lokasi resiko tinggi dan sangat tinggi	Lokasi Program	Tingkat kesesuaian lokasi	Rekomendasi	Main-streaming	
1	Faktor terkait dengan bahaya perubahan iklim (curah hujan, kenaikan muka laut)	1. Pengendalian vektor penyakit (berdasarkan informasi perubahan iklim)	Pengamatan Epidemiologi rutin (bulanan, 2 mingguan, mingguan)	<ul style="list-style-type: none"> <li>• <a href="#">Program Upaya Kesehatan Masyarakat</a> (Penyelenggaraan pencegahan dan penanggulangan penyakit menular dan wabah)</li> <li>• <a href="#">Program Pencegahan dan Penanggulangan Penyakit Menular</a> (penyemprotan foging nyamuk, pelayanan pencegahan &amp; penanggulangan penyakit menular, Peningkatan surveillan epidemiologi dan penanggulangan wabah) (Dinas Kesehatan)</li> </ul>	Surveillans epidemologi tidak terlalu rutin	<ul style="list-style-type: none"> <li>• Timur: Lingkas Ujung (Existing)</li> <li>• Utara: Juata Permai, Juata Kerikil (2030)</li> </ul>	---	Tidak sesuai	<ul style="list-style-type: none"> <li>• Kegiatan lebih rutin dan lebih sering, khususnya:               <ul style="list-style-type: none"> <li>- Saat terjadinya genangan air laut di pesisir</li> <li>- Saat terjadi peningkatan kasus sesuai data historis</li> <li>- Lokasi terutama di daerah risiko tinggi</li> </ul> </li> <li>• Monitoring tingkat resistensi nyamuk terhadap penggunaan pestisida untuk penyemprotan</li> </ul>	Program 2013	
2			Pemberantasan sumber habitat sarang nyamuk melalui Program Perbaikan Lingkungan		Sudah sesuai tapi waktu kegiatan tidak sesuai		---	Tidak sesuai			
3			Penyemprotan pada dinding rumah dan bangunan secara rutin 6 bulan sekali		Sudah sesuai tapi waktu kegiatan tidak sesuai		---	Tidak sesuai			
4			Sosialisasi tentang APD (alat pelindung diri; contoh: pengusir nyamuk, jaring nyamuk, kelambu celup, semprotan nyamuk, dan pakaian yang sesuai)	Kegiatan sesuai tapi materi belum sesuai	---		Tidak sesuai	<ul style="list-style-type: none"> <li>• Materi sosialisasi lebih disesuaikan kebutuhan (opsi-opsi adaptasi), khususnya:               <ul style="list-style-type: none"> <li>• sosialisasi tentang kelambu celup (rekomendasi WHO)</li> <li>• kearifan lokal (Waktu kegiatan sesuai dengan catatan tersebut di atas)</li> </ul> </li> </ul>			Program 2013
5			Sosialisasi tentang alat pelindung rumah (contoh: kawat kasa anti nyamuk pada pintu dan jendela)	Kegiatan sesuai tapi materi belum sesuai	---		Tidak sesuai				
6			Sosialisasi kearifan lokal: Pengalihan sasaran vektor pada hewan mamalia (kera, sapi); Penanaman pohon anti nyamuk;	Kegiatan sesuai tapi materi belum sesuai	---		Tidak sesuai				

No	Faktor bahaya, kerentanan	Tipe opsi adaptasi expert	Opsi adaptasi usulan expert	Rencana Program 2012 (RKP, APBD)	Tingkat kesesuaian program	Lokasi resiko tinggi dan sangat tinggi	Lokasi Program	Tingkat kesesuaian lokasi	Rekomendasi	Main-streaming
			Pemeliharaan ikan							
7	Faktor terkait dengan: <ul style="list-style-type: none"> <li>Bahaya iklim (curah hujan, kenaikan muka laut)</li> <li>Populasi yang dekat sarang nyamuk (rawa, mangrove)</li> <li>Kebersihan lingkungan rumah</li> </ul>	2. Perbaikan lingkungan	Mengurangi genangan air laut di pesisir dan/ atau memasukkan musuh biologis (ikan) atau desalinasi pada tempat genangan yang tidak bisa dikeringkan	---	Tidak sesuai	<ul style="list-style-type: none"> <li>Timur: Lingkas Ujung (Existing)</li> <li>Utara: Juata Permai, Juata Kerikil (2030)</li> </ul>	---	Tidak sesuai	Program penataan kawasan kumuh pesisir (sesuai dgn. rekomendasi Sektor Pesisir) <ul style="list-style-type: none"> <li>Peraturan ttg. Penataan Lingkungan Sehat: <ul style="list-style-type: none"> <li>SE Walikota/Bupati,</li> <li>Peraturan Walikota/Bupati</li> <li>Perda</li> <li>SK Bersama Menkes, MenLH, Mendagri</li> </ul> </li> <li>Lokasi kegiatan difokuskan pada daerah-daerah beresiko tinggi</li> </ul>	Program KKP: "Desa Tahan Bencana" Kemenera Kementerian PU (Cipta Karya)  Kemen LH: Koordinasi ttg. SKB Menkes, MenLH, Mendagri tentang Penataan Lingkungan Sehat
8			Restorasi hutan lindung dengan menambahkan hewan mamalia (kera dsb.)	---	Tidak sesuai		---	Tidak sesuai	FGD Malang dan Mengusulkan restorasi hutan lindung dengan tambahan hewan mamalia (kera dsb.)	Lintas sektor dgn. Dinhut, DKP, DPU
9	Faktor terkait: <ul style="list-style-type: none"> <li>Bahaya iklim (curah hujan, kenaikan muka laut)</li> <li>Fasilitas kesehatan</li> </ul>	3. Pengawasan/pengamatan agen penyakit	Pengamatan rutin parasit malaria (menghitung Indeks Malaria dan Indeks Kepadatan Nyamuk) oleh malariologist dan entomologist	---	Tidak sesuai		---	Tidak sesuai	Monitoring parasit secara rutin oleh Dinkes	Program 2013

### c. Diarhea Hazard

No	Faktor bahaya, kerentanan	Tipe opsi adaptasi expert	Opsi adaptasi usulan expert	Rencana Program 2012 (RKP, APBD)	Tingkat kesesuaian program	Lokasi resiko tinggi dan sangat tinggi	Lokasi Program	Tingkat kesesuaian lokasi	Rekomendasi	Main-streaming		
1	Faktor terkait dengan: • Bahaya iklim (suhu, curah hujan) • Tingkat populasi • Fasilitas sanitasi rumah • Fasilitas air bersih untuk minum	1. Pengendalian pencemaran air domestik di kawasan perumahan rawan banjir, genangan pesisir, dan kumuh	Sosialisasi dan penyediaan fasilitas air sumur yang bersih (air berklorin)	<ul style="list-style-type: none"> <li>• <a href="#">Program Upaya Kesehatan Masyarakat</a> (penyelenggaraan penyehatan lingkungan)</li> <li>• <a href="#">Program Promosi Kesehatan &amp; Pemberdayaan Masyarakat</a> (penyuluhan masy. pola hidup sehat) (Dinas Kesehatan)</li> </ul>	Sudah sesuai	<ul style="list-style-type: none"> <li>• Timur: Lingkas Ujung (Existing, 2030), Gunung Lingkas, Mamburungan, Kampung Empat (2030)</li> <li>• Tengah: Selumit Pantai, Pamusian (2030)</li> <li>• Barat: Karang Rejo, Karang Balik, Karang Anyar Pantai, Karang Harapan (2030)</li> <li>• Utara: Juata Permai (2030), Juata Kerikil, Juata Laut (Existing, 2030)</li> </ul>	---	Tidak sesuai	Strategi penyuluhan tentang Perilaku Bersih dan Sehat dan tentang Lingkungan sedini mungkin (kurikulum TK, SD)	Kemen-dikbud		
2			Sosialisasi dan penyediaan fasilitas air minum yang steril (penyaringan, direbus)	<ul style="list-style-type: none"> <li>• <a href="#">Program pengembangan dan pengelolaan jaringan irigasi, rawa dan jaringan pengairan lainnya</a> (Pembangunan jaringan air bersih/air minum) (DPUTR)</li> </ul>	Sudah sesuai		---	Tidak sesuai				
3			Sosialisasi pemanfaatan air minum dalam kemasan	<ul style="list-style-type: none"> <li>• <a href="#">Program pengembangan dan pengelolaan jaringan irigasi, rawa dan jaringan pengairan lainnya</a> (Pembangunan jaringan air bersih/air minum) (DPUTR)</li> </ul>	Kegiatan sesuai tapi materi tidak sesuai		---	Tidak sesuai			<ul style="list-style-type: none"> <li>• Sosialisasi pemanfaatan air minum dlm. kemasan</li> <li>• Penegakan hukum (air kemasan diuji ulang setiap 6 bulan sekali)</li> </ul>	Program 2013
4			Penanganan air bersih dalam mitigasi kebencanaan	(Tersedia SOP mtigasi kebencanaan dari BNPB)	Kegiatan sesuai		---	Tidak sesuai			Dinkes perlu berkoordinasi dgn. BPBD utk. penyediaan air bersih di pengungsian	BNPb
5	Faktor terkait dengan: • Bahaya iklim (suhu, curah hujan) • Tingkat populasi • Fasilitas sanitasi rumah • Fasilitas air bersih untuk minum	2. Pengendalian air limbah domestik di lingkungan rawan banjir, genangan pesisir, & kumuh	Sosialisasi dan penyediaan fasilitas toilet umum dan septik tank di perumahan	<ul style="list-style-type: none"> <li>• <a href="#">Program Lingkungan Sehat Perumahan</a> (pembuatan rencana strategis sanitasi, penyusunan masterplan sanitasi) (Bappeda)</li> <li>• <a href="#">Program Pembangunan saluran drainase/ qorong-qorong</a> (DPUTR)</li> <li>• <a href="#">Program Upaya Kesehatan Masyarakat</a> (penyelenggaraan penyehatan lingkungan)</li> <li>• <a href="#">Program pengembangan lingkungan sehat</a> (Dinas Kesehatan)</li> </ul>	Sudah sesuai tapi belum terintegrasi		---	Tidak sesuai	Perbaikan Sanitasi • Program Rumah Sehat • Program MCK Sehat Optimalisasi Program Sanitasi Total Berbasis Masyarakat (STBM) → Terutama pada daerah rawan bencana banjir (lokasi risiko tinggi)	<ul style="list-style-type: none"> <li>• Kemensos</li> <li>• CSR</li> <li>• Kemenpera</li> <li>• Kemen-PU (Cipta karya)</li> <li>• Kemenkes</li> </ul>		
6			Sosialisasi dan penyediaan fasilitas drainase air limbah perkotaan	<ul style="list-style-type: none"> <li>• <a href="#">Program Lingkungan Sehat Perumahan</a> (pembuatan rencana strategis sanitasi, penyusunan masterplan sanitasi) (Bappeda)</li> <li>• <a href="#">Program Pembangunan saluran drainase/ qorong-qorong</a> (DPUTR)</li> <li>• <a href="#">Program Upaya Kesehatan Masyarakat</a> (penyelenggaraan penyehatan lingkungan)</li> <li>• <a href="#">Program pengembangan lingkungan sehat</a> (Dinas Kesehatan)</li> </ul>	Sudah sesuai tapi belum terintegrasi		---	Tidak sesuai				
7			Pemberian kaporit pada sumur-sumur gali	<a href="#">Program Upaya Kesehatan Masyarakat</a>	Sudah sesuai; tapi perlu		---	Tidak sesuai				



No	Faktor bahaya, kerentanan	Tipe opsi adaptasi expert	Opsi adaptasi usulan expert	Rencana Program 2012 (RKP, APBD)	Tingkat kesesuaian program	Lokasi resiko tinggi dan sangat tinggi	Lokasi Program	Tingkat kesesuaian lokasi	Rekomendasi	Main-streaming
				(penyelenggaraan penyehatan lingkungan) (Dinas Kesehatan)	program kontinu					
8	Faktor terkait: • Bahaya iklim (suhu, curah hujan) • Fasilitas kesehatan	3. Pengawasan/pengamatan agen penyakit	Pengamatan/pemeriksaan agen penyebab di lab klinik/RS/Labkesda	(Ada Lab Kesehatan Daerah)	Sudah sesuai, tapi perlu lebih efektif		---	Tidak sesuai	<ul style="list-style-type: none"> <li>• Perlu sistem jejaring antar lab klinik swasta, RS, dan Labkesda yang dikordinasikan oleh Dinkes</li> <li>• Pembebasan biaya pada rakyat kurang mampu utk pemeriksaan air ke Labkesda, terutama yang tinggal di lokasi risiko tinggi dan pada saat KLB</li> </ul>	<ul style="list-style-type: none"> <li>• Kemenkes</li> <li>• Program 2013</li> </ul>

#### d. General (for the Three Hazards)

No	Faktor bahaya, kerentanan	Tipe opsi adaptasi expert	Opsi adaptasi usulan expert	Rencana Program 2012 (RKP, APBD)	Tingkat kesesuaian program	Rekomendasi	Main-streaming
1	Faktor terkait dengan fasilitas kesehatan: • Fasilitas operasional kesehatan	4. Manajemen infeksi manusia (Monitoring & Evaluasi)	Menyusun <u>sistem informasi dan pelaporan kasus penyakit</u> secara online dengan penyiapan infrastruktur untuk menunjang sistem manual yang sudah ada	<u>Program Standarisasi Pelayanan Kesehatan</u> (Penyusunan standar pelayanan kesehatan, Pembentukan dan pemutakhiran data dasar pelayanan kesehatan, Monitoring, evaluasi dan pelaporan, Regulasi dan manajemen mutu pelayanan kesehatan) (Dinas Kesehatan)	Standarisasi sudah ada tapi belum online	Perbaiki sistem informasi dan pelaporan kasus: <ul style="list-style-type: none"> <li>• Integrasi sistem (manual, telpon, dan komputer)</li> <li>• Sistem online hanya untuk kalangan terkait/terbatas</li> <li>• Fokus di daerah berpotensi KLB</li> <li>• Perlu verifikator untuk mengecek kualitas data/informasi</li> <li>• Analisis data statistik</li> </ul>	Program 2013
2	• Sumber daya manusia bidang kesehatan • Kapasitas kelembagaan		Monitoring Epidemologis rutin (bulanan, 2 mingguan, mingguan, harian) yang dikaitkan dengan <u>Sistem Peringatan Dini DBD</u> (Integrasi hasil surveilans vektor, laporan kasus, pengamatan serologi, dan pengamatan cuaca)	"Sistem" yang ada masih manual dan belum memperhatikan iklim	Penyusunan Sistem Peringatan Dini DBD (kerjasama Dinas Kesehatan, RS, dan BMKG)	<ul style="list-style-type: none"> <li>• Kemenkes</li> <li>• BMKG</li> <li>• Dikti Kemen-dikbud</li> </ul>	
3			Penyempurnaan sistem dan infrastruktur sehingga <u>penanganan kasus penyakit</u> sehingga mudah diakses/dijangkau masyarakat	Sudah sesuai	Menambah kemudahan akses masyarakat: <ul style="list-style-type: none"> <li>- Menambah Fasilitas Pelayanan Kesehatan</li> <li>- Menambah SDM Kesehatan</li> <li>- Fokus di daerah risiko tinggi</li> </ul>	Program 2013	

No	Faktor bahaya, kerentanan	Tipe opsi adaptasi expert	Opsi adaptasi usulan expert	Rencana Program 2012 (RKP, APBD)	Tingkat kesesuaian program	Rekomendasi	Main-streaming		
4			Peningkatan kesadaran dan edukasi masyarakat secara intensif untuk kesiapsiagaan pada saat peralihan musim	<a href="#">Program Promosi Kesehatan dan Pemberdayaan Masyarakat</a> (program pengembangan media promosi dan informasi sadar hidup sehat, penyuluhan masyarakat pola hidup sehat) (Dinas Kesehatan)	Kegiatan sesuai tapi materi belum sesuai	Program Promosi Kesehatan harus mencakup semua aspek kesehatan masyarakat, termasuk dampak perubahan iklim di sektor kesehatan	Program 2013		
5			Pemberdayaan masyarakat untuk mengetahui Tata Laksana DBD, Malaria, Diare secara sederhana						
6			Penjaminan persediaan sarana penunjang diagnosis (khususnya di LabKesda)	<ul style="list-style-type: none"> <li>• <a href="#">Program Obat dan Perbekalan Kesehatan</a></li> <li>• <a href="#">Program Upaya Kesehatan Masyarakat</a> (pencegahan dan penanggulangan penyakit menular dan wabah, pelayanan kesehatan masy.) (Dinas Kesehatan)</li> </ul>	Sudah sesuai, namun belum memperhatikan lokasi risiko tinggi setiap penyakit			Persediaan sarana dan prasarana serta obat-obatan difokuskan di daerah-daerah risiko tinggi setiap penyakit	Program 2013
7			Penjaminan persediaan obat: <ul style="list-style-type: none"> <li>- Cairan infus</li> <li>- Transfusi darah (DBD)</li> <li>- Obat anti-malaria</li> <li>- Obat anti-diare</li> </ul>						
8			Faktor terkait dengan fasilitas kesehatan: <ul style="list-style-type: none"> <li>• Fasilitas operasional kesehatan</li> </ul>	5. Penyediaan dan pengembangan sumber daya manusia bidang kesehatan	Penyediaan tenaga lapangan untuk surveillans DBD dan malaria: <ul style="list-style-type: none"> <li>• Epidemiologist DBD</li> <li>• Entomologist (DBD, malaria)</li> <li>• Malarialogist</li> </ul>	---	Belum sesuai, baru ada epidemologist	Pembentukan Jurusan Biologi Universitas Borneo Pembentukan Sekolah Tinggi Kesehatan (STIKES) dan Politeknik Kesehatan (Poltekes) di Tarakan	<ul style="list-style-type: none"> <li>• Kemenkes</li> <li>• Kemen-dikbud</li> </ul>
9			Sumber daya manusia bidang kesehatan		Penyediaan tenaga laboratorium: <ul style="list-style-type: none"> <li>• Clinic analyst</li> <li>• Virologist (DBD)</li> </ul>	---	Belum sesuai		
10			Kapasitas kelembagaan		Penyediaan tenaga paramedis dan medis yang terlatih dan terampil untuk menangani penyakit DBD, Malaria, Diare	(Tersedia Ak. Perawat di Tarakan dan Fak. Kedokteran di Univ. Mulawarman Samarinda)	Sesuai tapi kualitas masih perlu ditingkatkan	Pembentukan Fakultas Kedokteran/ Fakultas Kesehatan Masyarakat di Universitas Borneo	Dikti Kemen-dikbud
11		Tersedianya dokter spesialis penyakit <i>tropical medicine</i> , mikrobiologi, dan parasit sebagai rujukan	(Tersedia Fak. Kedokteran di Univ. Mulawarman Samarinda)		Belum sesuai	Perlu penyesuaian terhadap kurikulum spesialis di FK Universitas Mulawarman	Program 2013		
12		Pengembangan LSM untuk membantu aktivitas bidang kesehatan (Jumantik, <i>outreach</i> )	---		Belum sesuai	Pembentukan Jurusan Biologi Universitas Borneo	Program 2013		

No	Faktor bahaya, kerentanan	Tipe opsi adaptasi expert	Opsi adaptasi usulan expert	Rencana Program 2012 (RKP, APBD)	Tingkat kesesuaian program	Rekomendasi	Main-streaming
13		6. Peningkatan sumber pendanaan sektor kesehatan	Mengusahakan peningkatan porsi anggaran kesehatan dalam APBD dan APBN sesuai dengan UU (10%)	(Tersedia porsi anggaran saat ini)	Belum fokus untuk kesehatan	Mengusulkan penambahan porsi anggaran sektor kesehatan sehingga sesuai dengan UU (10%)	Program 2013
14			Peraturan tentang pemanfaatan dana CSR untuk kesehatan	(Tersedia Peraturan tentang pemanfaatan dana CSR secara umum)	Belum fokus untuk kesehatan	Mengusulkan revisi peraturan tentang pemanfaatan dana CSR sehingga ada <u>dana CSR untuk kesehatan dan lingkungan</u>	Program 2013

## A.2 Synchronization/Policy Matrices

### A.2.1 Coastal Sector

Risiko	Ops Expert	No	Program/Kegiatan Daerah yang Terkait Adaptasi Perubahan Iklim	Instansi Penanggung Jawab	Stakeholders			Program Stakeholders tahun 2013 yang Terkait	Rekomendasi Lokasi		
					Pusat	Swasta/ BUMN	Lain-Lain				
Pengenangan air laut di pesisir	Akomodasi-proteksi	1	Program penataan kawasan perkampungan kumuh pesisir secara menyeluruh dan terintegrasi	DPUTR	Kemen-PU DJCK; Kemen-Pera			Pembangunan Perumahan (Kemenpera), target 60ribu rumah			
			1.1							Peninggian level lantai bangunan	
		3	Program penataan kawasan tambak	DPUTR	Kemen-PU DJCK; Kemen-KP DJPB						
			3.1								Peninggian level tanggul dan pematang tambak
	Proteksi struktur lunak	4	Program Pengembangan dan Pematapan Kawasan Konservasi Laut, Suaka Perikanan, dan Keanekaragaman Hayati Laut	BPLH	Kemen-KP DJKP3K				1. Program Pengelolaan SD Laut P3K; 2. Program Pengelolaan dan Pengembangan Konservasi dan Kawasan dan Jenis 3. Program Pendayagunaan Pesisir dan Lautan (Kemen-KP DJKP3K)		
			4.1								Sosialisasi pelestarian pohon
			4.2								Penanaman Pohon Endemik Kec. Tarakan
			4.3								Restorasi hutan pantai (mangrove dan pinus)
			4.4								Restorasi mangrove
	4.5	Pembangunan gumuk pasir pantai (sand dune)									
Pengenangan air laut di pesisir	Proteksi struktur keras	6	Program pengendalian banjir	DPUTR	Kemen-KP DJKP3K Kemen-PU DJCK			1. Program Pengelolaan SD Laut P3K; 2. Program Pendayagunaan Pesisir dan Lautan (Kemen-KP DJKP3K)			
			6.1							Pembangunan prasarana pengaman pantai: sea wall (tembok pantai, revetment)	
		6.2	Pembangunan prasarana pengaman pantai: jetty (penahan abrasi), breakwater (alat pemecah ombak)	DPUTR; DKPP							
		6.3	Peningkatan pembersihan dan pengerukan sungai/kali								
		6.4	Proteksi dengan teknologi (hard) pada area genangan sepanjang sungai								

Risiko	Ops Expert	No	Program/Kegiatan Daerah yang Terkait Adaptasi Perubahan Iklim		Instansi Penanggung Jawab	Stakeholders			Program Stakeholders tahun 2013 yang Terkait	Rekomendasi Lokasi
						Pusat	Swasta/ BUMN	Lain-Lain		
	Integrated coastal zone management (ICZM) (Pengelolaan pesisir ter-integrasi)	7	Program Perencanaan Tata Ruang		DPUTR	Kemen-PU DJPR; Kemen-KP DJKP3K; Bappenas			1. Program Pengelolaan SD Laut P3K; 2. Program Penataan Ruang dan Perencanaan Pengelolaan Wilayah Laut P3K (Kemen-KP DJKP3K)	
7.1			Penyusunan RDTRK Tarakan Utara, Timur, Tengah							
7.2			Sosialisasi RTRW Kota Tarakan							
8		Program pengelolaan pesisir terintegrasi melalui pengelolaan garis pantai - managed realignment)		DPUTR	Kemen-KP DJKP3K; Kemen-PU DJCK; Bappenas					
		8.1	Pengisian ulang pasir pantai (beach nourishment)							
		8.2	Penataan ulang kawasan pesisir							
		8.3	Relokasi rumah, sarana, dan prasarana menjauhi garis pantai (coastal setback)							
	Terkait dengan: Program pengembangan wilayah strategis dan cepat tumbuh									
	12	Monitoring, evaluasi, dan pelaporan pelaksanaan Rencana Pembangunan Daerah		DPUTR						

## A.2.2 Water Sector

Risiko	Opsi Expert	No	Program Daerah Terkait Adaptasi PI	Instansi Penanggung Jawab	Stakeholders			Program Stakeholders tahun 2013 yang Terkait	Rekomendasi Lokasi
					Pusat	Swasta/BUMN	Lain-Lain		
Penurunan Ketersediaan Air	Terkait dengan Opsi Air Baku dan Air Minum/ PDAM	1	Program peningkatan pelayanan air bersih kepada pelanggan	Dinas PU-TR; PDAM	Kemen-PU DJCK				
		1.1	Optimalisasi penyediaan air dari PDAM untuk Sub Zona 1A						
		1.2	Untuk Sub Zona 1B, optimasi penyediaan air sebagian dari PDAM dan lainnya dengan pemanfaatan air tanah tertekan (kedalaman rata-rata: 96,8 m)						
		1.3	Pengembangan IPAs baru, memanfaatkan DAS Bengawan dan Semunti dengan potensi debit 0,60 m <sup>3</sup> /dtk atau 18,932 jt m <sup>3</sup> /th						
		1.4	Pengembangan reservoir untuk melengkapi IPAs baru						
		1.5	Pemanfaatan air tanah dari lapisan akuifer yang terletak 130 m di bawah permukaan tanah						
		1.6	Pemanfaatan air permukaan untuk Zona 3A dan 3B						
		1.7	Pembangunan reservoir di Sungai Mangantai untuk Sub Zona 3A						
		1.8	Pengembangan reservoir untuk Sub Zona 3B DAS B						
		3.a	DED Tampung Air Baku	Dinas PU-TR; PDAM	Kemen-PU DJSDA			Masuk ke program 5	
		3.b	Program pengolah air siap minum	PDAM	Kemen-PU DJCK				
		3.1	Optimalisasi IPA Binalatung untuk Sub Zona 4A						
		3.2	Pemanfaatan air tanah untuk Sub Zona 4B						
		3.3	Desalinasi air laut						
		3.4	Panen air hujan						
	Terkait dengan Opsi Konservasi	5	Program konservasi air permukaan dan air tanah		Kemen-PU DJSDA; Kemen-ESDM				

Risiko	Opsi Expert	No	Program Daerah Terkait Adaptasi PI		Instansi Penanggung Jawab	Stakeholders			Program Stakeholders tahun 2013 yang Terkait	Rekomendasi Lokasi
						Pusat	Swasta/BUMN	Lain-Lain		
Sumber Daya Air		5.1	Pengamanan hutan							
		5.2	Pemagaran hutan							
		5.3	perencanaan dan tata bahas kawasan hutan							
Banjir	Terkait dengan Opsi Normalisasi Sungai	3	Manajemen Sumber Daya Air Terpadu (IWRM)		Dinas PU-TR	Kemen PU DJSDA				
		3.1	Rehabilitasi/normalisasi saluran sungai							
		3.2	Pemulihan Fungsi Sungai dan Kolam							
		4	Program Pelaksanaan Normalisasi Sungai		Dinas PU-TR	Kemen PU DJSDA				
		4.1	Rehabilitasi Normalisasi saluran Sungai							
		4.2	Pembangunan saluran drainase/gorong-gorong							
		4.3	Program Koordinasi pengelolaan Prokasih/Superkasih							
		4.4	Program peningkatan pembersihan dan pengerukan Sungai/kali							
	4.5	Pemasangan gerbang pintu air di sungai, tanggul, dan pemompaan.								
	Terkait dengan Opsi Pembangunan Drainase/ Pengendalian Banjir	5	Program Pembangunan saluran drainase/gorong-gorong		Dinas PU-TR	Kemen PU DJCK				
Longsor	Terkait dengan Opsi Konservasi/reboisasi	1	Program Penghijauan Lingkungan		Dishutam-ben	KLH				
		1.1	Forestasi							
	Terkait dengan Opsi Drainase/ Sungai	3	Program pembangunan saluran drainase/gorong-gorong		Dinas PU-TR	Kemen PU DJCK				
		3.1	Pembangunan sistem drainase							
Terkait dengan Opsi Rekayasa	5.a	Program rekayasa pengendalian stabilitas lereng jalan		Dinas PU-TR	Kemen PU Bina Marga;					

Risiko	Opsi Expert	No	Program Daerah Terkait Adaptasi PI	Instansi Penanggung Jawab	Stakeholders			Program Stakeholders tahun 2013 yang Terkait	Rekomendasi Lokasi
					Pusat	Swasta/BUMN	Lain-Lain		
	Lereng Jalan				Kemen ESDM				
		5.1	Modifikasi geometri lereng						
		5.2	Modifikasi drainase						
		5.3	Modifikasi struktur dinding penahan tanah						
		5.4	Perkuatan lereng						



### A.2.3 Health Sector

Risiko	Opsis Expert	No	Program/Kegiatan Daerah yang Terkait Adaptasi Perubahan Iklim	Instansi Penanggung Jawab	Stakeholders			Program Stakeholders tahun 2013 yang Terkait	Rekomendasi Lokasi	
					Pusat	Swasta/BUMN	Lain-Lain			
Penyakit DBD	Pengendalian vektor penyakit	1	Program Pencegahan dan Penanggulangan Penyakit Menular	1. Dinas Kesehatan; 2. Kemenkes-Kantor Kesehatan Pelabuhan	Kemenkes DJ-P2PL					
			Terkait dengan: Program Upaya Kesehatan Masyarakat							
			1.1		Penyemprotan (fogging) nyamuk	1. Kemenkes Dir. PPBB Vektor; 2. Kemenkes-Kantor Kesehatan Pelabuhan			Fogging di permukiman di sekitar pelabuhan dan bandara (Tarakan)	
			1.2		Pelayanan pencegahan dan penanggulangan penyakit menular	Kemenkes Arbovirosis				
			1.3		Peningkatan surveilans epidemiologi dan penanggulangan wabah	Kemenkes Simkarkesmas				
			1.4		Surveillans vector DBD rutin di setiap desa/ kelurahan oleh entomologist lapangan	Kemenkes Arbovirosis, Simkarkesmas				
			1.5		Pemberantasan sumber habitat sarang nyamuk dengan program 3M Plus dan PSN secara rutin					
			1.6		Abatisasi dan atau pemakaian IGR (misal Altosid) di lokasi sarang nyamuk					
	Pengendalian vektor penyakit dan perbaikan lingkungan	2	Program Promosi Kesehatan dan Pemberdayaan Masyarakat	Dinas Kesehatan	Kemenkes Pusat Promosi; Kemen-dagri (?)					
			Terkait dg: Program pengembangan media promosi dan informasi sadar hidup sehat							
			2.1			Penyuluhan masyarakat mengenai pola hidup sehat				
			2.2		Peningkatan pendidikan tenaga penyuluh kesehatan	Kemenkes PPSDM				
			2.3		Penyuluhan masyarakat tentang APD (alat pelindung diri) seperti pengusir nyamuk, jaring nyamuk, kelambu celup, semprotan nyamuk, pakaian sesuai.	Kemenkes Pusat Promosi + Arbovirosis				

Risiko	Opsi Expert	No	Program/Kegiatan Daerah yang Terkait Adaptasi Perubahan Iklim	Instansi Penanggung Jawab	Stakeholders			Program Stakeholders tahun 2013 yang Terkait	Rekomendasi Lokasi
					Pusat	Swasta/BUMN	Lain-Lain		
			2.4	Penyuluhan masyarakat tentang alat pelindung rumah (kawat anti nyamuk di pintu dan jendela)					
			2.5	Penyuluhan masyarakat untuk mengurangi genangan dan/atau memasukkan musuh biologis/predator (ikan nila, ikan cupang, dsb) pada tempat genangan.					
	Perbaikan Lingkungan	3	Program pengembangan dan pengelolaan jaringan irigasi, rawa dan jaringan pengairan lainnya (Pembangunan jaringan air bersih/air minum)		Dinas PU Tata Ruang	Kemen-PU DJCK		Infrastruktur drainase perkotaan (DJCK)	sesuai
Terkait dengan: Program Pembangunan saluran drainase/gorong-gorong									
3.1			Perbaikan saluran drainase/pembuangan air hujan						
3.2			Peningkatan pelayanan air bersih perpipaan						
4		Program Penyediaan dan Pengelolaan Air Baku		Dinas PU Tata Ruang; PDAM	Kemen-PU DJCK		Penyelenggaraan sistem air minum yang terfasilitasi (DJCK); PAMSIMAS		
		4.1	Peningkatan pelayanan air bersih perpipaan (PDAM) dan non-perpipaan						
5	Program Pengembangan Lingkungan Sehat		Dinas Kesehatan	Kemenkes Peny. Lingkungan, Kemen-PU DJCK					
	5.1	Pengendalian nyamuk di dalam perumahan dan bangunan umum, di pekarangan dan sekitarnya							
	Pengawasan/pengamatan agen penyakit	6	Program pengawasan /pengamatan agen penyakit		Kemenkes Litbangkes, Arbovirosis, UPT Balai Besar Teknik Kesehatan Lingk. & Pemberantasan Penyakit; Kemendikbud-Dikti				
6.1			Monitoring serologi virus DBD secara berkala oleh virologist						
6.2			Pengembangan percobaan vaksin DBD						
Penyakit Malaria	Pengendalian vektor penyakit	1	Program Pencegahan dan Penanggulangan Penyakit Menular		Dinas Kesehatan	Kemenkes DJ-P2PL			

Risiko	Opsi Expert	No	Program/Kegiatan Daerah yang Terkait Adaptasi Perubahan Iklim	Instansi Penanggung Jawab	Stakeholders			Program Stakeholders tahun 2013 yang Terkait	Rekomendasi Lokasi				
					Pusat	Swasta/BUMN	Lain-Lain						
			Terkait dengan: Program Upaya Kesehatan Masyarakat										
			1.1						Penyemprotan fogging nyamuk		Global Fund	Fogging	
			1.2						Pelayanan pencegahan dan penanggulangan penyakit menular				
			1.3						Peningkatan surveilans epidemiologi dan penanggulangan wabah				
	Pengendalian vektor penyakit dan perbaikan lingkungan	2	Program Promosi Kesehatan dan Pemberdayaan Masyarakat		Dinas Kesehatan	Kemenkes Pusat Promosi							
			Terkait dg: Program pengembangan media promosi dan informasi sadar hidup sehat										
			2.1	Penyuluhan masyarakat mengenai pola hidup sehat									
			2.2	Peningkatan pendidikan tenaga penyuluh kesehatan									
			2.3	Penyuluhan masyarakat tentang APD (alat pelindung diri) seperti pengusir nyamuk, jaring nyamuk, kelambu celup, semprotan nyamuk, pakaian sesuai.									
			2.4	Penyuluhan masyarakat tentang alat pelindung rumah (kawat anti nyamuk di pintu dan jendela)									
2.5	Penyuluhan kearifan lokal: Pengalihan sasaran vektor pada hewan mamalia (kera, sapi); Pena-naman pohon anti nyamuk; Pemeliharaan ikan												
		4.2	Restorasi hutan lindung dan mangrove dengan menambahkan hewan mamalia (kera dsb.)					Restorasi mangrove (KLH, KemenHut, Kemen-KP);					
Pengawasan/ pengamatan agen penyakit	5	Program pengawasan / pengamatan agen penyakit		Dinas Kesehatan	Kemenkes Litbangkes								
		5.1	Pengamatan rutin parasit malaria (menghitung Indeks Malaria dan Indeks Kepadatan Nyamuk) oleh malariologist dan entomologist										
Penyakit Diare	Pengendalian vektor penyakit	1	Program Promosi Kesehatan & Pemberdayaan Masyarakat	Dinas Kesehatan	Kemenkes Pusat Promosi	PT Unilever (CSR)		Iklan masyarakat; Penyuluhan UKS ;					

Risiko	Opsi Expert	No	Program/Kegiatan Daerah yang Terkait Adaptasi Perubahan Iklim	Instansi Penanggung Jawab	Stakeholders			Program Stakeholders tahun 2013 yang Terkait	Rekomendasi Lokasi				
					Pusat	Swasta/BUMN	Lain-Lain						
	dan perbaikan lingkungan		Terkait dengan: Program Upaya Kesehatan Masyarakat										
			1.1						Penyuluhan masyarakat tentang pola hidup sehat				
			1.2						Penyuluhan mengenai fasilitas air sumur yang bersih (air berklorin)				
			1.3						Penyuluhan mengenai fasilitas air minum yang steril (penyaringan, direbus)				
			1.4						Penyuluhan mengenai pemanfaatan air minum dalam kemasan				
	Perbaikan Lingkungan		2	Program pengembangan dan pengelolaan jaringan irigasi, rawa dan jaringan pengairan lainnya	Dinas PU Tata Ruang	Kemen-PU SDA							
				Terkait dengan: Program Upaya Kesehatan Masyarakat		Kemenkes DJ-P2PL							
			2.1	Pembangunan jaringan air bersih/air minum		Kemen PU DJCK	HIPAM						
			2.2	Klorinasi terhadap sumur gali dan tempat penampungan air	Dinas Kesehatan								
			2.3	Peningkatan kualitas air menjadi air siap minum	Dinas PUTR; PDAM								
			2.4	Pengawasan kualitas air minum dalam kemasan/ isi ulang	Dinas Kesehatan	Badan POM							
			3	Program penambahan pada SOP mitigasi bencana	BNPB	PP Krisi, Matra, PKS Darurat							
				3.1			Mempertimbangkan penanganan air bersih dalam mitigasi kebencanaan						
			4	Program Lingkungan Sehat Perumahan:	Bappeda	Pokja Perum. Bappenas; Kemen-pera + Kemen PU DJCK; Kemenkes; Kemen-KP							
				4.1			Pembuatan rencana strategis sanitasi						
4.2	Penyusunan masterplan sanitasi												
4.3	Penyuluhan dan penyediaan fasilitas toilet umum dan septik tank di perumahan					Rumah sederhana dan sehat (Kemen-Pera); Program Kota Sehat (Kemenkes/Bappeda); Desa Pesisir Tangguh Bencana (Kemen-KP)							
5	Program Pembangunan saluran drainase/ gorong-gorong	Dinas PU Tata Ruang	Kemen-PU DJCK										
	5.1			Penyuluhan dan penyediaan fasilitas drainase air limbah perkotaan									

Risiko	Opsi Expert	No	Program/Kegiatan Daerah yang Terkait Adaptasi Perubahan Iklim	Instansi Penanggung Jawab	Stakeholders			Program Stakeholders tahun 2013 yang Terkait	Rekomendasi Lokasi
					Pusat	Swasta/BUMN	Lain-Lain		
		6	Program Upaya Kesehatan Masyarakat	Dinas Kesehatan					
			6.1		Pemberian kaporit pada sumur-sumur gali	Subdit Air			
	Pengawasan/pengamatan agen penyakit	7	Program pengawasan/pengamatan agen penyakit	Dinas Kesehatan	Kemenkes Litbangkes, Surveillans				
			7.1			Pengamatan/pemeriksaan agen penyebab di lab klinik/RS/Labkesda			
Umum (DBD, Malaria, Diare)	Manajemen Infeksi Manusia	1	Program Standarisasi Pelayanan Kesehatan	Dinas Kesehatan					
			1.1		Menyusun sistem dan infrastruktur informasi dan pelaporan kasus penyakit secara online untuk menunjang sistem manual yang sudah ada				
			1.2		Monitoring Epidemologis rutin (bulanan, 2 mingguan, mingguan, harian) yang dikaitkan dengan Sistem Peringatan Dini DBD (integrasi hasil surveilans vektor, laporan kasus, pengamatan serologi, dan pengamatan cuaca)				
			1.3		Penyempurnaan sistem dan infrastruktur penanganan kasus penyakit sehingga mudah dan cepat terjangkau masyarakat				
		2	Program promosi kesehatan dan pemberdayaan masyarakat						
			2.1		Peningkatan kesadaran dan edukasi masyarakat secara intensif pada saat peralihan musim				
			2.2		Pemberdayaan masyarakat untuk Tata Laksana DBD, Malaria, Diare				
		3	Program Obat dan Perbekalan Kesehatan						
			Terkait dengan: Program Upaya Kesehatan Masyarakat						
			3.1		Penjaminan persediaan sarana penunjang diagnosis (khususnya di LabKesda)				
		3.2	Penjaminan persediaan obat: Cairan infus, Transfusi darah (DBD), Obat						

Risiko	Opsi Expert	No	Program/Kegiatan Daerah yang Terkait Adaptasi Perubahan Iklim	Instansi Penanggung Jawab	Stakeholders			Program Stakeholders tahun 2013 yang Terkait	Rekomendasi Lokasi
					Pusat	Swasta/BUMN	Lain-Lain		
			anti-malaria, Obat anti-diare						
Umum (DBD, Malaria, Diare)	Penyediaan dan pengembangan sumber daya manusia bidang kesehatan	4	Pengembangan sumber daya manusia bidang kesehatan	Dinas Kesehatan					
		4,1	Penyediaan tenaga lapangan: Epidemiologist DBD, Entomologist (DBD, malaria), Malariologist						
		4,2	Penyediaan tenaga laboratorium: Clinic analyst, Virologist (DBD)						
		4,3	Penyediaan dokter umum Plus dan tenaga perawat, khusus yang berpengalaman menangani penyakit DBD, Malaria, Diare						
		4,4	Penyediaan dokter spesialis penyakit menular, khususnya patologi klinik, mikrobiologi klinik, parasitologi klinik						
		4,5	Pengembangan LSM untuk membantu aktivitas bidang kesehatan (Jumantik, outreach)						
	Peningkatan sumber pendanaan sektor kesehatan	5	Peningkatan sumber pendanaan sektor kesehatan	Dinas Kesehatan					
		5,1	Mengusahakan peningkatan porsi anggaran kesehatan dalam APBD dan APBN						
		5,2	Peraturan tentang pemanfaatan dana CSR untuk kesehatan						

### A.3 Champion Program

Program Unggulan/ Program Terpadu	Sektor Terkait	Program Sektor Terkait	Kegiatan yang Terkait	Kementerian/ Lembaga Terkait	Antisipasi terhadap Risiko Perubahan-an Iklim	Faktor Dominan Kerentanan
Program Penataan Kawasan Kumuh Pesisir Tarakan Barat secara Terpadu dan Menyeluruh	Pesisir	Program Penataan Kawasan Kumuh Pesisir	<ul style="list-style-type: none"> <li>• Survei topografi detail, garis pantai, dan level bangunan pantai</li> <li>• Peninggian level lantai bangunan</li> </ul>	Kemen-Pera; Kemen-KP DJKP3K; Kemen-PU DJCK	Penggenangan air laut di pesisir	<ul style="list-style-type: none"> <li>• Kepadatan penduduk tinggi dengan tingkat sosial- ekonomi yang relatif kurang, sehingga memperbesar peluang penularan penyakit seperti DBD dan diare</li> <li>• Topografi pesisir landai, sehingga memperlama waktu penggenangan, baik oleh air laut, air hujan, dan air sungai serta beresiko timbulnya penyakit malaria</li> <li>• Banyaknya infrastruktur, misalnya bandara, industri pengolahan hasil perikanan</li> </ul>
	Air	Program Pelaksanaan Normalisasi Sungai	<ul style="list-style-type: none"> <li>• Rehabilitasi/ normalisasi saluran sungai</li> <li>• Program peningkatan pembersihan dan pengerukan sungai/kali</li> </ul>	Kemen-PU DJSDA	Banjir	
	Kesehatan	Program Pencegahan dan Penanggulangan Penyakit Menular	<ul style="list-style-type: none"> <li>• Penyemprotan (fogging) nyamuk</li> <li>• Pemberantasan Sarang Nyamuk (PSN) dan Program 3M Plus secara rutin</li> <li>• Pelayanan pencegahan dan penanggulangan penyakit menular</li> </ul>	Kemenkes DJP2PL	<ul style="list-style-type: none"> <li>• Penyakit Demam Berdarah Dengue (DBD)</li> <li>• Penyakit Malaria</li> </ul>	
		Program Penyediaan dan Pengelolaan Air Baku	Peningkatan pelayanan air bersih perpipaan (PDAM)	Kemen-PU DJCK	<ul style="list-style-type: none"> <li>• Penyakit DBD</li> <li>• Penyakit Diare</li> </ul>	
Program Inventarisasi dan Standarisasi Data Terkait Perubahan Iklim	Basis Sain- tifik	Program Inventarisasi dan Standarisasi Data Terkait Iklim	<ul style="list-style-type: none"> <li>• Standarisasi data iklim</li> <li>• Standarisasi data kelautan</li> <li>• Inventarisasi data iklim</li> <li>• Inventarisasi data kelautan</li> </ul>	BMKG; Badan Informasi Geospasial; Kemen-Ristek LIPI LAPAN	Semua risiko sektoral	Kurangnya kuantitas data yang tidak memenuhi standarisasi data iklim dapat menyebabkan kurangnya akurasi hasil analisis dan proyeksi perubahan iklim, yang pada gilirannya dapat menimbulkan kurang-tepatnya rekomendasi adaptasi perubahan iklim







For further information, please  
contact :

nama \achmah waty	di eter .rul ez	di di . ar j i mi
Ministry of Environment		us . .
Jedung .lt . , Jl . . . andjaitan	Ministry of Environment	Australian Embassy
Jav . .	Jedung .lt . ,	Jl . . \ . Nasuna ai d . av . . .
Jakarta	Jl . . . andjaitan . av . .	Jakarta .
Indonesia	Jakarta Indonesia	Indonesia
adaptation.me.id@gmail.com	di eter .brulez .gi z .de	di di . . ar j i mi . aus ai d . gov . au